

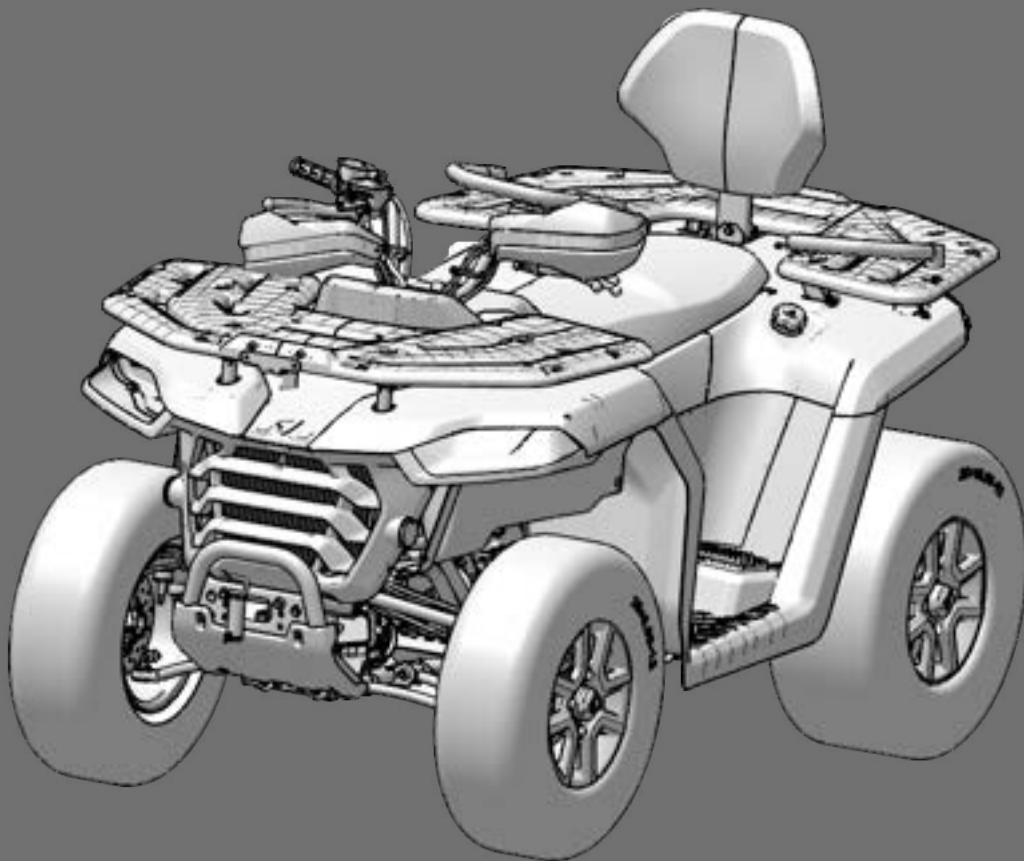

**450 ATV
SERIES MODELS**

SERVICE MANUAL



2025/5/7 V1.0

INDEX

GENERAL INFORMATION	1-1
REGULAR MAINTENANCE	2-1
ENGINE	3-1
FRONT AND REAR AXLE	4-1
FUEL SYSTEM	5-1
COOLING SYSTEM	6-1
INTAKE SYSTEM	7-1
DRIVE CHAIN SYSTEM	8-1
FRONT AND REAR SUSPENSION	9-1
WHEEL AND TIRE	10-1
BRAKE SYSTEM	11-1
STEERING SYSTEM	12-1
FRAME/BODY AND TRIM	13-1
ELECTRICAL SYSTEM	14-1

SUMMARY

This manual provides information on diagnostics, maintenance procedures, adjustments and specifications for the 450ATV series for use by service technicians.

All materials, illustrations and product descriptions contained in this manual are in accordance with the status at the time of publication to ensure the efficient safety of vehicles, continuous research and development, may lead to parts of the manual account do not tally with the vehicle actual situation, so the state of the vehicle body shall prevail, when in doubt it is suggested that you contact the Segway Powersports dealership, for the latest status of this manual or information relating to the product part number or special tools.

No part of this manual may be reproduced or stored in any form without the permission of Segway Technology Ltd.

The above statement applies to all text, images, and forms.

1. This manual is provided by Segway Technology Ltd. and is intended for qualified professional and technical personnel.

If you do not have the proper training and do not proper tools and equipment, attempting to perform repairs and maintenance can injure the repairer himself or others, and may also damage the vehicle or cause it to not be operated properly.

2. Proper vehicle maintenance and repair is very important for the personal safety of maintenance personnel and the safe, reliable operation of motor vehicles. If you need to replace a part, please use the same part or the part specified by Segway, do not use parts that are not recognized by Segway. Do not use parts not approved by Segway for replacement.

3. The recommended maintenance procedures described in this manual are an effective way to perform repairs and maintenance, some of which require the use of specialized tools.

Therefore, if replacement parts, repair procedures or tools not approved or recommended by Segway are used, you must first verify that there is no risk to personal safety or safe operation of the vehicle. or safe operation of the vehicle.



SEGWAY TECHNOLOGY CO., LTD.

POWERSPORTS.SEGWAY.COM

TERMINOLOGY

A	ampere(s)	lb	pounds(s)
ABDC	after bottom dead center	m	meter(s)
AC	alternating current	mm	Millimeter(s)
ATDC	after top dead center	min	minute(s)
BBDC	before bottom dead center	N	newton(s)
BDC	bottom dead center	Nm	Newton meters
BTDC	before top dead center	Pa	pascal(s)
C	degree(s) Celcius	HP(PS)	horsepower
CVT	centrifugal variable Transmission	psi	pound(s) per square inch
DC	direct current	r	revolution
F	farad(s)	rpm	revolution(s) per minute
F	degree(s) Fahrenheit	TDC	top dead center
ft	foot, feet	TIR	total indicator reading
g	gram(s)	V	volt(s)
kg/cm ²	Kilograms per square centimeter	W	watt(s)
h	hour(s)	Ω	ohm(s)
L	liter(s)		

This manual is applicable to the following vehicle models::

SGW500F-A1\SGW500F-A3\SGW500F-A5\SGW500F-A7

Segway AT5 \Segway AT5 S \Segway AT5 EPS

SGW500F-A2\SGW500F-A4\SGW500F-A6\SGW500F-A8

Segway AT5 L\Segway AT5 Touring EPS

NOTES BEFORE MAINTENANCE

This manual includes a variety of "warnings", "attention", "tips", etc., which must be carefully followed in order to reduce the risk of injury during repair or maintenance. Improper repair or maintenance will damage the vehicle or bring safety hazards to the vehicle.

⚠ WARNING

WARNING indicates a potential hazard that may result in severe injury or death to the operator, bystander or person(s) inspecting or servicing the vehicle.

⚠ CAUTION

CAUTION indicates a potential hazard that may result in personal injury or damage to the vehicle.

TIPS

TIPS provide maintenance information to give the corresponding reminder, express and explanation.

IMPORTANT

IMPORTANT provides key reminders during disassembly, assembly, and inspection of components.

Please understand the construction, performance, repair methods and safety requirements of the vehicle being repaired before servicing.

Preparation of tools and gauges

Prepare the necessary tools and measuring instruments before the repair work.

Specialized tools

The disassembly of some parts requires the use of special tools, please do not use other tools instead.

Parts disassembly

Before repair work, first identify the cause of the malfunction and confirm whether disassembly or disassembly is required based on the actual condition of the malfunction.

Disassemble

If the disassembly process is complex and requires too many parts to be disassembled, take care that the performance or shape of all parts is not damaged.

Parts

When parts are damaged and need to be replaced, use parts approved or recommended by Segway.

Replacements

All components should be assembled with strict adherence to standard values such as torque and indeed adjustment values.

If disassembled, the following parts must be replaced with new ones:

- shims
- O-ring
- cotter pin

Use the recommended lubricant in the specified position before assembly

Rubber parts and hoses

Prevent rubber parts and hoses from coming into contact with gasoline or lubricating oil.

GENERAL INFORMATION

VEHICLE IDENTIFICATION NUMBER/ENGINE SERIAL CODE1-2
TECHNICAL PARAMETERS OF VEHICLE1-3
UNIT CONVERSION TABLE1-6
TORQUE1-7

VEHICLE IDENTIFICATION NUMBER/ENGINE SERIAL CODE

VEHICLE IDENTIFICATION NUMBER

The vehicle identification number is located on the frame cross tube under the seat cushion and the engine number is embossed on the engine. It is used to assist the customer when ordering spare parts from the dealer or as a reference in case the vehicle is stolen. when the customer needs to order spare parts from the dealer or as a reference in the event of theft of the vehicle..

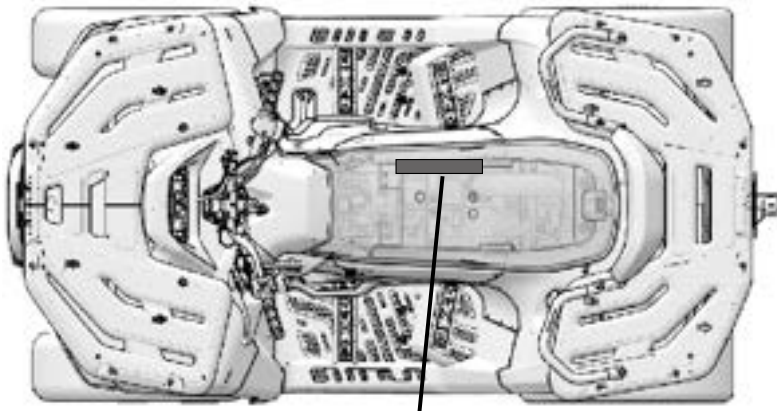

Vehicle Frame Identification Number (VFIN)

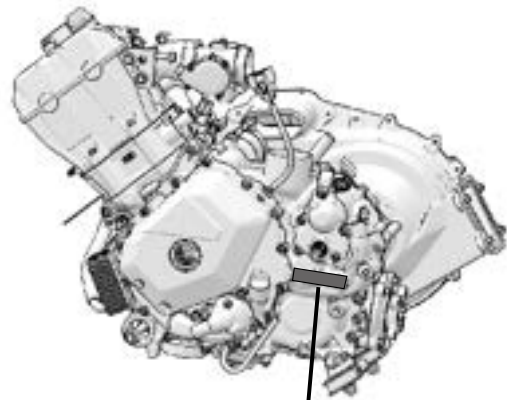

Engine Serial No.

VEHICLE IDENTIFICATION CODE COMPOSITION

A0SAAPX1? X X X X X X X X X X

1 2 3 4 5 6 7 8 9 10

No.	Serial Number Meaning	Digits	No.	Serial Number Meaning	Digits
1	OEM CODE	3	6	INSPECTION	1
2	MODEL	1	7	DATE	1
3	ENGINE CODE	1	8	SERIAL NUMBER	1
4	DISPLACEMENT	1	9	FACTOR NUMBER	1
5	POWER	1	10	PRODUCTION NUMBER	6

TECHNICAL PARAMETERS OF VEHICLE

Item	SGW500F-A1/A3/A5/A7	SGW500F-A2/A4/A6/A8
Vehicle		
Length	2160mm	2300mm
Width	1180mm	1180mm
Height	1230mm	1350mm
Wheel base	1305mm	1455mm
Ground clearance	Front: 235/Rear245	
Turning diameter	5900 mm	6400mm
Curb weight (no oil and gasoline)	372kg	389kg
Front rack load	40kg	
Rear rack load	60kg	
Recommended Traction quality (Pulled load quality)	300kg	
Engine		
Engine model	193MR	
Engine type	Four stroke, Single cylinder, Water cooled, Vertical, Double overhead camshaft	
Cylinder diameter × stroke	93×73.6	
Engine displacement	499 ml	
Compression ratio	10.6:1	
Maximum power	28kW / 7000 rpm	
Maximum torque	44N·m / 6000 rpm	
Idle speed	1350±100r/min	
Starting way	Electric starting	
Lubrication way	Pressure spray	
Engine oil type	SAE10W/40-SN OR HIGH	
Engine oil capacity (upkeep)	2.2L	
Front Differential gear oil type	SAE 80W/90/GL-5	
Change the volume(upkeep)	170ml	
Rear Differential gear oil type	SAE 80W/90/GL-5	
Change the volume(upkeep)	120ml (Non-differential)	260ml (Differential)
Air filter	Paper filter	
Fuel tank type	Barrier type plastic fuel tank	

Item	SGW500F-A1/A3/A5/A7	SGW500F-A2/A4/A6/A8
Fuel tank capacity	18L	
Reserve fuel capacity	4.5L	
Throttle type	42mm mechanical throttle body	
Spark plug type	CPR7EA/B7RTC	
Spark plug gap	0.7~0.9mm	
Transmission	CVT	
Shift sequence	L-H-N-R-P	
Transmission gear ratio	0.6-2.97	
L Gear Ratio	11.8-58.3	
H Gear Ratio	6.8-33.6	
R Gear Ratio	9.7-48	
Tire		
Tire type	Vacuum tires	
Front tire specification	24x8.00-12/25x8.00-12	
Rear tire specification	24x10.00-12/25x10.00-12	
Front tire pressure	48.3kPa	
Rear tire pressure	48.3kPa	
Brake System		
Brake type	Front dual-disc brake, rear single-disc brake (brake center drive shaft) / front dual-disc brake, rear dual-disc brake	
Foot Brake Type	Right foot. Action.	
Front Brake Type	Left hand. Action.	
Brake fluid type	DOT4	
Suspension System		
Front suspension	Front double A rocker arm	
Rear suspension	Rear double A rocker arm	
Front shock absorber	Spring + oil resistance Spring + air resistance	
Rear shock absorber	Spring + oil resistance Spring + air resistance	
Front wheel travel	200mm	
Rear wheel travel	200mm	

Item	SGW500F-A1/A3/A5/A7	SGW500F-A2/A4/A6/A8
Electrical System		
Ignition mode	Electric(ECU)	
Recharge batteries	450W / 5500 rpm	
Battery	12V 32Ah	
Headlight	Proximity optical power 9.5(W)	
	Remote Optical Power17(W) 32000cd	
	Daytime running light power 20(W)	
	Turn signal power 10 (W)	
	Front position lamp power2.7(W)	
Rear Tail Light - Position Light	0.2*2 or 2.1*1(W)	
Rear Tail Light-Brake Light	2.9*2 or 4.7*1(W)	
Turn indicator light	1.9W*2 or 2.4*2(W)	

UNIT CONVERSION TABLE

TORQUE		
Unit	coefficient	Convert to
N·m	× 0.1020	kg·m
N·m	×0.7376	ft·lbs
N·m	×8.851	in·lbs
kg·m	×9.807	N·m
kg·m	×7.233	ft·lbs
kg·m	×86.80	in·lbs
in·lbs	×0.833	ft·lbs
in·lbs	×0.116	kg·m
PRESSURE		
kPa	× 0.01020	kg/cm ²
kPa	× 0.1450	psi
kPa	× 0.7501	cmHg
kg/cm ²	× 98.07	kPa
kg/cm ²	× 14.22	psi
cm Hg	× 1.333	kPa
POWER		
N	× 0.1020	kg
N	× 0.2248	lb
kg	× 9.807	N
kg	× 2.205	lb
VOLUME		
L	× 0.2642	gal (US)
L	× 0.2200	gal (imp)
L	× 1.057	qt (US)
L	× 0.8799	qt (imp)
L	× 2.113	pint (US)
L	× 1.816	pint (imp)
mL	0.03381	oz (US)
mL	0.02816	oz (imp)
mL	0.06102	cu in
SPEED		
km/h	× 0.6214	mph
POWER		
kW	× 1.360	PS
kW	× 1.341	HP
PS	× 0.7355	kW
PS	× 0.9863	HP
TEMPERATURE		
°C to °F : °C x 9/5 + 32 = °F		
°F to °C : °F - 32 x 5/9 = °C		

TORQUE

The following tables list the tightening torque for the major fasteners, and the parts requiring use of a non-permanent locking agent or liquid gasket.

Letters used in the "Remarks" column mean:

L: Apply a non-permanent locking agent.

MO: Apply molybdenum disulfide oil solution (mixture of the engine oil and molybdenum disulfide grease in a weight ratio 10:1).

EO: Apply engine oil.

SS: Apply silicone sealant

Lh: Left-hand Threads

R: Replacement Parts

S: Follow the specific tightening sequence.

Item	Fastener Designator	Grade	Torque (N•m)	Remark
Engine Mounting Bolts	Engine Mounting Shaft1 (M12×1.25×335)	12.9	50 ~ 60	
	GB/T 5789 M8×16	8.8	20 ~ 30	
	GB/T 5789 M8×35	8.8	20 ~ 30	
	GB/T 5789 M12×1.25×210	10.9	50 ~ 60	
Front & Rear Axle Mounting Bolts	GB/T 5789 M10×1.25×20	8.8	40 ~ 50	
	GB/T 5789 M8×16	8.8	20 ~ 30	
	GB/T 5789 M10×1.25×105	10.9	40 ~ 50	L
	GB/T 5789 M10×1.25×75	10.9	40 ~ 50	L
Steering rocker arm special bolts	A03F11001101	10.9	30 ~ 40	L
Steel rim mounting nuts	(Thread M12×1.25)	10	70~80	
Aluminum rim mounting nuts	(Thread M12×1.25)	10	70~80	
Axle Mounting Nut	GB/T 9459 M24×2	10	220~250	
Front Steering Knuckle Lower Tightening Bolt	GB/T 5789 M10×1.25×45	10.9	40~50	
Shock absorber fastening bolts	GB/T 5789 M10×1.25×55	10.9	40~50	
Front and rear rocker arm fastening bolts	GB/T 5789 M10×1.25×75	10.9	55~65	
Balance Bar Tightening Bolts	GB/T 5789 M8×30	8.8	30 ~ 40	
Rear Axle Support Tightening Bolts	GB/T 5789 M10×1.25×100	10.9	40~50	
EPS Steering universal joint locking bolt	GB/T 5789 M8×30	8.8	30 ~ 40	
EPS Installation	GB/T 5789 M10×1.5×20	8.8	40~50	L
Steering Grip Cover Bolt	GB/T 70.1 M8×65	8.8	30 ~ 40	
Steering Column Plate Mounting Bolts	GB/T 5789 M8×16	8.8	20 ~ 30	

Item	Fastener Designator	Grade	Torque (N•m)	Remark
Wheel side caliper body mounting bolts	GB/T 5789 M10×1.25×25	8.8	40 ~ 50	L
Brake master cylinder mounting bolts	GB/T5789 M8×25	8.8	30 ~ 40	L
Brake disc mounting bolts	(Thread M8)	8.8	25 ~ 28	L
Center Axle Brake Disc Bolt	GB/T 70.1 M10×1.25×20	10.9	40 ~ 50	L
Center shaft caliper body bolts	GB/T 70.1 M10×1.25×50	10.9	40 ~ 50	L
Center shaft caliper body bolts	GB/T 70.1 M10×1.25×30	10.9	40 ~ 50	L
oxygen sensor	(Thread M18×1.5)	/	15 ~ 20	
Left crankcase	Oil Filter Fitting	/	40±5	
Left crankcase M5	Plugs for piston injection holes	/	4±0.3	L
Left crankcase	Oil regulator assembly M16	/	20±2	
Left tank oil duct port	Hexagonal flange face oil pipe bolts M8×30	8.8	12±2	
oil drain screw	Screw plug M14 assembly	/	18±2	
Active Bevel Gear Platen	Hexagon socket flower countersunk head screws M8×25	8.8	25±2	L
Drive Bevel Gear	Hexagonal flange face nut M22×1	10	180±5	L
Follower bevel gear shaft bearing end face	round nut M65×1.5×8-LH	/	137±5	L
Front and rear drive shaft end flanges	Bolt M12×1.25×30	10.9	120±8	L
Active Bevel Gear Bearing Housing -4	BoltM8×30	10.9	35±2	L
Rear drive shaft bearing end faces	round nut M55×1.5×6-LH	/	120±5	L
Slave Bevel Gear Housing -4	Bolt M8×35	8.8	35±2	L
Combination box M6×40-13; M6×65-4	Bolt M6	8.8	10±2	
Closing bolt cylinder -2	Bolt M8×70	8.8	26±2	
Clamping bolt at driven bevel gear -3	Bolt M8×40	8.8	26±2	
gear shift mechanism	Parking Locator Bolt	8.8	25±2	
gear shift mechanism	Shift Locator Bolt	8.8	25±2	
Transmission Hub Shift Gear	Hexagon head bolts M6×40	8.8	14±2	
Balance shaft oil pump active gear	Bolt M10×1.25×25	12.9	80±5	L
cylinder block	Oil Pressure Sensor	/	14±2	
Tensioning plate, guide plate	Hexagon socket pan head step bolts	8.8	12±2	
Timing Slave Sprocket	Hexagonal flange face bolts M6×12	12.9	18±2	L
Cylinder head	Cylinder head bolt combination M11×1.25×150	10.9	step1: 12N.m step2: 35N.m step3: 180° (70N.m ~ 120N.m)	
Cylinder head cover	Hexagon socket pan head step bolts	8.8	12±2	

Item	Fastener Designator	Grade	Torque (N•m)	Remark
cylinder head	spark plugs	/	13±2	
Magneto Overrunning Clutches	Hexagon socket cheese head screws M6×16	8.8	18±2	L
Crankshaft magneto rotor	Hexagonal flange face nuts M18×1.5	10	180±8	L
Crankshaft magneto rotor	peephole cover	/	12±2	
cylinder head	Coupling Plumbing Fittings	/	25±2	
inlet pipe	Hexagon socket cheese head screws M8×25	8.8	25±2	
CVT	CVT master wheel bolt M12×1.25×142	12.9	120±8	
CVT	CVT driven wheel bolt M10×1.25×80	12.9	80±5	
cylinder head	Exhaust port double-ended stud M8×43	10.9	25±2	L

MAINTENANCE

TECHNICAL SPECIFICATIONS	2-3
VEHICLE LIFTING SUPPORT POSITION	2-4
MAINTENANCE CYCLE TABLE	2-5
BREAK-IN MAINTENANCE	2-6
PERIODIC MAINTENANCE.....	2-6
REMAINING LUBRICATION FILLING	2-10
ENGINE MAINTENANCE	2-12
ENGINE OIL LEVEL CHECK	2-12
ENGINE OIL EMISSIONS	2-13
CLEANING THE FILTERS	2-14
CHANGING THE OIL FILTER	2-14
FILLING THE ENGINE OIL	2-15
ENGINE/FUEL TANK HOSE INSPECTION	2-16
ENGINE CYLINDER LEAKAGE TEST.....	2-16
VALVE LASH CHECK	2-17
FRONT GEARBOX AND REAR GEARBOX	2-18
CHECK FRONT AND REAR TRANSMISSION FLUID LEVELS.....	2-18
FRONT REDUCTION GEARBOX OIL DRAIN	2-19
FRONT REDUCTION GEARBOX GEAR OIL FILLING	2-19
REAR REDUCTION GEARBOX DRAIN	2-20
REAR REDUCTION GEARBOX GEAR OIL FILLING.....	2-20
SHIFT LEVER INSPECTION/ADJUSTMENT	2-21
COOLING SYSTEM	2-22
COOLING SYSTEM OVERVIEW.....	2-22
COOLING SYSTEM HOSES	2-22
RADIATOR CHECK.....	2-23
COOLANT BOTTLE COOLANT LEVEL CHECK AND REFILL.....	2-23
COOLANT REPLACEMENT	2-24
INTAKE AND EXHAUST MAINTENANCE	2-25
AIR FILTER	2-25
AIR FILTER DRAIN CHECK	2-25
SPARK ARRESTOR.....	2-26
EXHAUST HEAT SHIELD INSPECTION	2-26
FUEL SYSTEM AND AIR INTAKE	2-27
FUEL SYSTEM.....	2-27

FUEL FILTER	2-27
FUEL LINE	2-28
CVT	2-29
CVT INTAKE SCREEN CHECK.....	2-29
CVT BELT.....	2-29
DRY CVT.....	2-30
INSTALLATION OF DRIVE BELTS	2-30
DRIVE SHAFT DUST SLEEVE INSPECTION.....	2-31
WHEEL PARTS REMOVAL.....	2-31
WHEEL MOUNTING	2-31
TIRE TREAD DEPTH.....	2-32
TIRE PRESSURE CHECK.....	2-32
STEERING SYSTEM CHECK.....	2-33
POWER STEERING (EPS MODELS).....	2-33
TRANSVERSE TIE ROD INSPECTION	2-34
ANTERIOR BEAM CHECK.....	2-34
FRONT BEAM ADJUSTMENT	2-35
SHOCK ABSORBER	2-36
SHOCK ABSORBER INSPECTION.....	2-36
ADJUSTABLE PNEUMATIC SHOCK ADJUSTMENT	2-36
OIL SHOCK ABSORBER ADJUSTMENT	2-37
BRAKING SYSTEM	2-38
BRAKE FLUID LEVEL CHECK ON HANDBRAKE UPPER PUMP.....	2-38
BRAKE FLUID CUP LEVEL CHECK.....	2-39
BRAKE LININGS AND DISCS	2-39
BRAKE PEDAL AIR TRAVEL CHECK.....	2-40
PARKING HANDLE WORKING STROKE CHECK.....	2-40
PARKING HANDLE FREE TRAVEL ADJUSTMENT.....	2-40
ELECTRICAL AND IGNITION SYSTEMS	2-41
BATTERY MAINTENANCE	2-41
BATTERY REMOVAL.....	2-41
BATTERY INSTALLATION	2-42
BATTERY CHARGING.....	2-42
SPARK PLUGS	2-43
SPARK PLUG CHECK.....	2-43
THROTTLE CABLE FREE TRAVEL CHECK AND ADJUSTMENT	2-44
THROTTLE LEVER FREE PLAY CHECK	2-44

TECHNICAL SPECIFICATIONS

General specifications		
Item	standard	usage limit
Cylinder leakage	—	20%
Intake valve clearance (cold)	0.1 ~ 0.15mm (0.0039" ~ 0.0059")	—
Exhaust valve clearance (cold)	0.2 ~ 0.25mm (0.0079" ~ 0.0098")	—
Front Tire Pressure	7 psi (48 kPa)	—
Rear Tire Pressure	7 psi (48 kPa)	—
Wheel Front Beam	-5 ~ 5mm	—
Shock spring adjustment	1~5	—
Brake Pad Thickness	5mm	0.060 (1.5 mm)
Brake Disc Thickness	5mm	0.170 (4.32 mm)
Spark Plug Model	NGK CPR7EA / TORCH B7RTC	

Fluid Specifications		
Item	model number	Capacity
oil	SAE10W-40/SN or higher	2200 ml
Engine coolant	differential	3300 ml
Front Gear box Fluid	SAE 80W-90 GL5	170 ml
Rear Gear Box Fluid	SAE 80W-90 GL5	120ml (non-differentia) 260ml (differential)
brake fluid	DOT4	—
grease nipple	Universal Joint Lubricant	grease nipple
Universal Joint Lubricant	Universal Joint Lubricant	grease nipple
fuels	87#、 92#	18 L

VEHICLE LIFTING SUPPORT POSITION

Park the vehicle on a flat, non-slip surface. Make sure the vehicle shift lever is set to Park.

To lift the front or rear of the vehicle, place the jacks at the left and right centers of the front or rear of the vehicle as shown below:

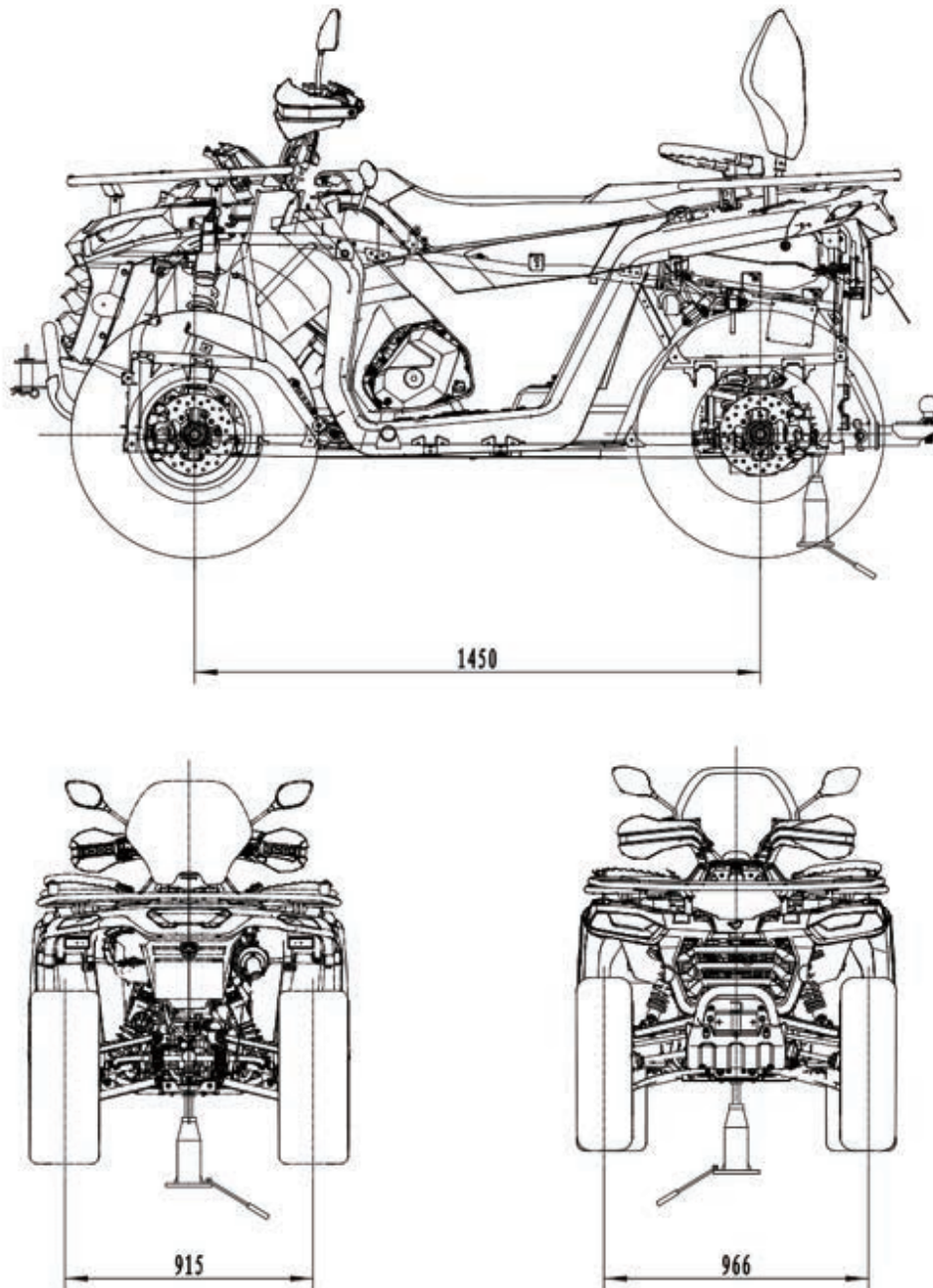

Schematic diagram of jack stands location

MAINTENANCE CYCLE TABLE

The periodic maintenance table describes the inspection, adjustment and lubrication of important parts. Inspect, clean, lubricate, adjust and replace parts as necessary. When inspections indicate the need for replacement parts, use genuine Segway parts from your Segway dealer.

SYMBOL	DESCRIPTION
▶	Perform these procedures more often for vehicles subjected to severe use.
D	Have an authorized dealer or other qualified person perform these services.

Heavy use is defined:

- ◆ Frequent immersion in mud, water, or sand
- ◆ Frequent or prolonged operation in dusty environments
- ◆ Short trip cold weather operation
- ◆ Racing or racing style high RPM use
- ◆ Long periods of low-speed, heavy-duty operation
- ◆ Idle vehicles for long periods of time

WARNING

The D-marking process may cause component failure and result in serious injury or death. Have an authorized dealer or other qualified person perform these services.

Perform all services with the first arriving maintenance condition. Record maintenance and services in the maintenance log.

Break-in period

The break-in period is the first 25 hours or 320km of vehicle operation (whichever comes first).

Start by driving slowly, varying the throttle angle, and do not operate at constant idle.

Regularly check fluid levels, control switches and components on the daily pre-driving checklist.

During break-in, change the oil and filter within 25 hours or 320km (whichever comes first).

For additional break-in information, refer to the Owner's Manual.

BREAK-IN MAINTENANCE

ITEM		MAINTENANCE INTERVAL (WHICHEVER COMES FIRST)			REMARKS
		HOURS	CALENDAR	MILES (KM)	
	Fuel System	25 H	1 M	200 (320)	Break-in check: cycle key to pressurize fuel pump. check lines and fittings for leaks and abrasion
	Engine oil change	25 H	1 M	200 (320)	Break-in check: oil and filter change
	Front gearcase oil	25 H	1 M	200 (320)	Break-in check: oil level check
	Rear gearcase oil	25 H	1 M	200 (320)	Break-in check: oil level check

PERIODIC MAINTENANCE

Make sure to perform proper maintenance at recommended intervals as indicated in the tables. Some items of the maintenance schedule must be performed in function of the calendar, regardless of the distance or time of operation.

ITEM		MAINTENANCE INTERVAL (WHICHEVER COMES FIRST)			REMARKS
		HOURS	CALENDAR	MILES (KM)	
▶	Brake pad wear	10 H	Monthly	100 (160)	Inspect periodically. replace as needed
	Battery	20 H	Monthly	200 (320)	Check terminals. clean. test
▶	Air filter, main element	50H		500 (800)	Inspect. replace as needed. inspect frequently if subjected to severe use
▶	General lubrication	50 H	3 M	500 (800)	Lubricate all fittings, pivots, cables, etc.
	Throttle Body Intake Duct	50 H	6 M	500 (800)	Inspect duct for proper sealing/air leaks
	Drive belt	50 H	6 M	500 (800)	Inspect. adjust. replace as needed
	Cooling system	100 H	12 M	1000 (1600)	Inspect coolant strength seasonally. pressure test system yearly
▶	Engine oil change	100 H	12 M	1000 (1600)	Change the oil and filter

ITEM		MAINTENANCE INTERVAL (WHICHEVER COMES FIRST)			REMARKS
		HOURS	CALENDAR	MILES (KM)	
▶	Oil lines and fasteners	100 H	12 M	1000 (1600)	Inspect for leaks and loose fittings
▶	Front gearcase oil	100 H	12 M	1000 (1600)	Change fluid.
▶	Rear gearcase oil	100 H	12 M	1000 (1600)	Change fluid
D	Fuel system/filter	100 H	12 M	1000 (1600)	Cycle key to pressurize fuel pump. check for leaks at fill cap, fuel lines/rail and fuel pump. replace lines every two years
▶	Radiator (if applicable)	100 H	12 M	1000 (1600)	Inspect. clean external surfaces
▶	Cooling hoses (if applicable)	100 H	12 M	1000 (1600)	Inspect for leaks
▶	Engine mounts	100 H	12 M	1000 (1600)	Inspect
	Exhaust muffler/ pipe / Joints	100 H	12 M	1000 (1600)	Inspect. clean. replace worn parts
D	Spark plug	100 H	12 M	1000 (1600)	Inspect. replace as needed
D	Clutches (drive and driven)	100 H	12 M	1000 (1600)	Inspect. clean. replace worn parts
D	Front wheel bearings	100 H	12 M	1000 (1600)	Inspect. replace as needed
D	Brake fluid	200 H	24 M	2000(3200)	Change every two years
	Spark arrester	300 H	36 M	3000(4800)	Clean out
▶	Coolant		60 M		Replace coolant
D	Valve clearance	500 H		5000(8000)	Inspect. adjust
	Idle speed				Adjust as needed
D	Toe adjustment				Inspect periodically. adjust when parts are replaced
	Headlight aim				Adjust as needed

Maintenance Reference

Item	Recommended Model	Capacity	Inspection Method	Schedule
Engine	SAE10W-40/SN or higher	2200 mL	Maintain level in safe range on dipstick	Refer to Maintenance Schedule
Engine Coolant		3300 mL	Maintain the level between the fill lines.	Refer to Maintenance Schedule

Engine Oil

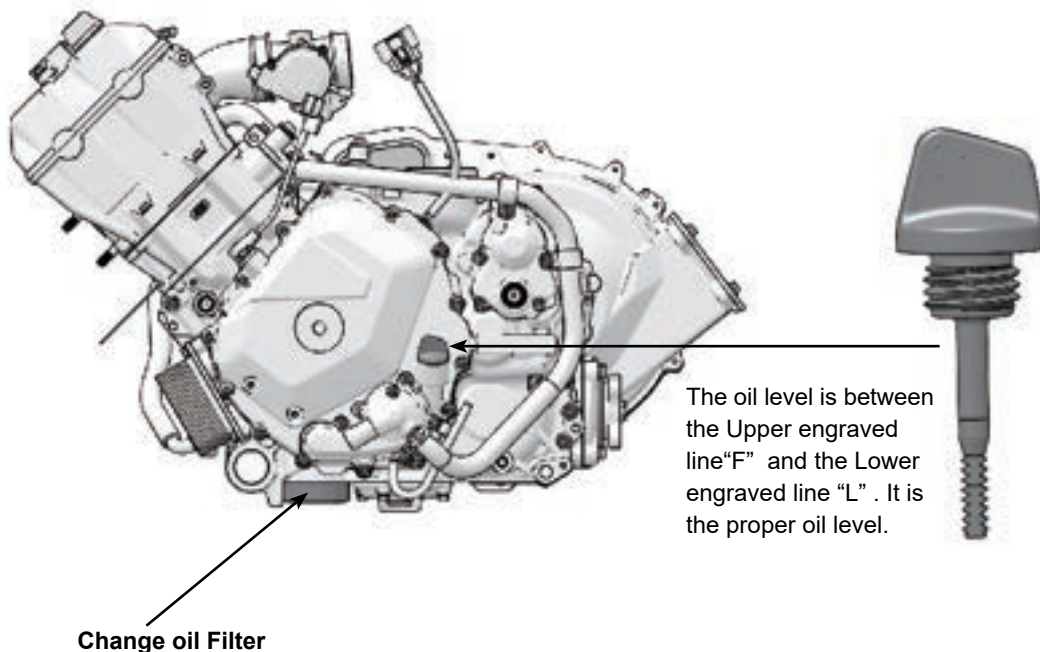

Engine Coolant

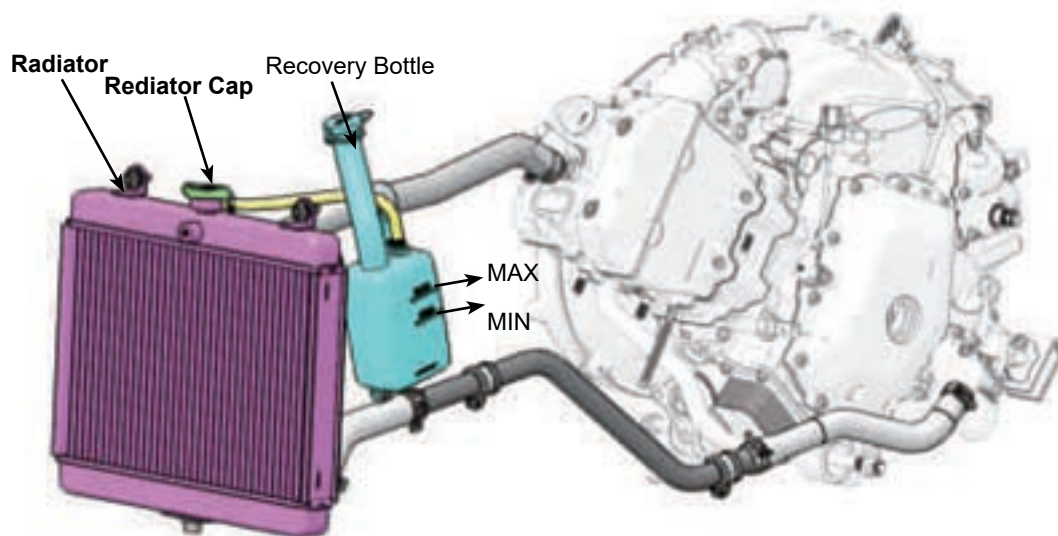

Item	Recommended Model	Capacity	Inspection Method	Schedule
Brake fluid	DOT4	---	Maintain the level between the fill lines.	Refer to Maintenance Schedule
Front axle gear oil	SAE 80W-90 GL5	170 mL	Maintain the fluid to the Fill Plug level	Refer to Maintenance Schedule
Rear axle gear oil	SAE 80W-90 GL5	120 mL (non-differential) 260 mL(differential)	Maintain the fluid to the Fill Plug level	Refer to Maintenance Schedule

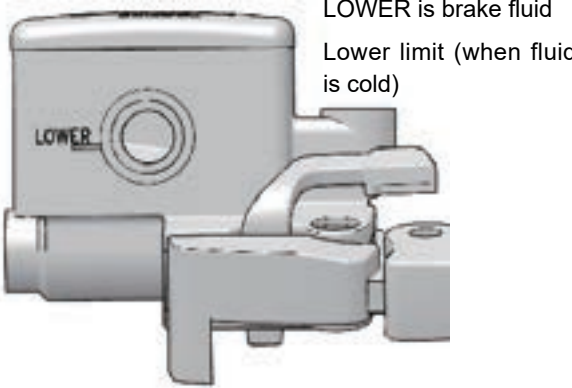
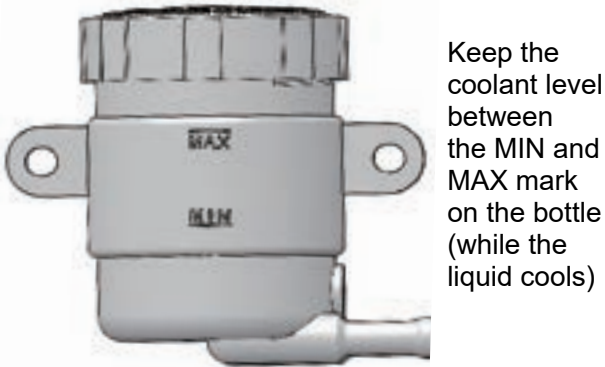
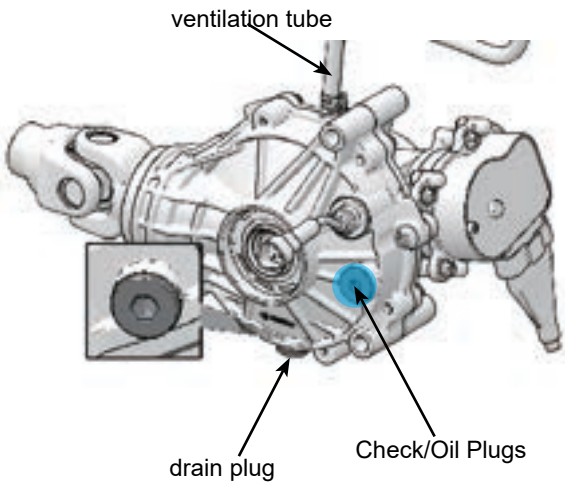
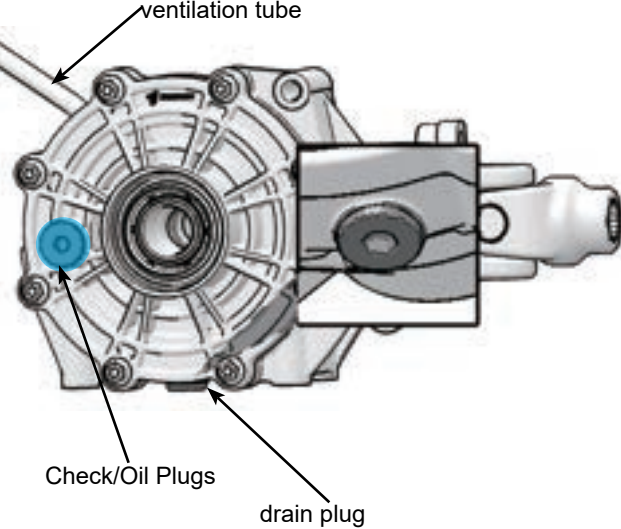
<p>Hand brake upper pump brake fluid cup</p>  <p>LOWER is brake fluid Lower limit (when fluid is cold)</p>	<p>Brake fluid</p>  <p>Keep the coolant level between the MIN and MAX mark on the bottle (while the liquid cools)</p>
<p>Front axle gear oil</p>  <p>ventilation tube</p> <p>drain plug</p> <p>Check/Oil Plugs</p>	<p>Rear Axle Gear Oil</p>  <p>ventilation tube</p> <p>Check/Oil Plugs</p> <p>drain plug</p>

Grease

The front and rear suspension arms, balance rods and driving shafts of the vehicle are designed with fueling nozzles. Grease these parts with lubricating oil regularly, make sure these parts are dry before filling.

Item	Recommended Model	Capacity	Inspection Method	Schedule
Rear axle support	Lithium grease	Grease Fittings (2 pumps max.)	Grease Fittings (2 pumps max.)	Per 1600 miles
Rear Balance Bar	Lithium grease	Grease Fittings (2 pumps max.)	Grease Fittings (2 pumps max.)	Per 1600 miles

Rear axle support (left and right)/Rear balance bar



■ Lubricating Oil Service

REMAINING LUBRICATION FILLING

Oil filling part	number of locations	Annotations
Internal and external splines for drive shafts	3 locations	Lithium grease, no overflow
Inside rocker arm cushion sleeve	14 locations	Lithium grease, no overflow
Front and rear half shaft inner ball cage splines	4 locations	Lithium grease, no overflow
Inside front and rear balance bar cushion bushings	4 locations	Lithium grease, no overflow
Brake pedal spindle	1 locations	Lithium grease, no overflow
Shift rocker arm pivot	1 locations	Lithium grease, no overflow
Frame Grounding Points	2 locations	Lithium grease, no overflow

GENERAL VEHICLE INSPECTION AND MAINTENANCE**Pre-Ride / Daily Inspection**

Perform the following pre-ride inspection daily, and when servicing the vehicle at each scheduled maintenance.

- ◆ Engine Oil - Check for proper level on dipstick located in oil tank (refer to “Engine Oil Level” procedure)
- ◆ Tires - check condition and pressures
- ◆ Fuel tank - fill to proper level
- ◆ All brakes - check operation and fluid level and adjustment (includes parking brake on INT’L Model)
- ◆ Throttle - check for free operation and closing
- ◆ Headlights/Taillights/Brakelights - also check operation of all indicator lights, instrument cluster and switches
- ◆ Ignition switch - check for proper function
- ◆ Wheels - check for tightness of wheel nuts and axle nuts. check to be sure axle nuts are secured by cotter pins
- ◆ Engine Intake Pre-Filter - Inspect pre-filter and clean with soapy water and compressed air if necessary
- ◆ Steering - check for free operation noting any unusual looseness in any area
- ◆ Loose parts - visually inspect vehicle for any damaged or loose nuts, bolts or fasteners
- ◆ Engine coolant - check for proper level at the recovery bottle
- ◆ Drive Shaft Boots - Inspect inner and outer boots for tears or damage on both front and rear drive shafts
- ◆ Check all front and rear suspension components for wear or damage.
- ◆ Frame, Nuts, Bolts, and Fasteners
- ◆ Periodically inspect the torque of all fasteners in accordance with the maintenance schedule. Check that all cotter pins are in place. Refer to specific fastener torques listed in each chapter.

ENGINE MAINTENANCE

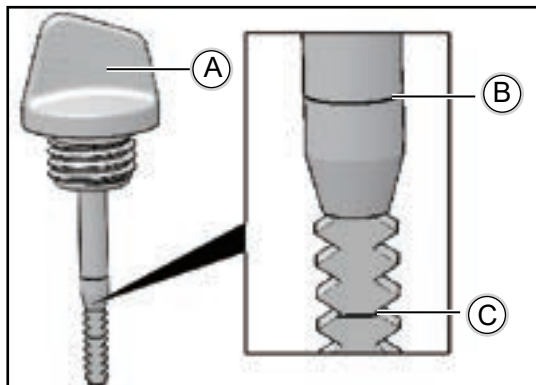
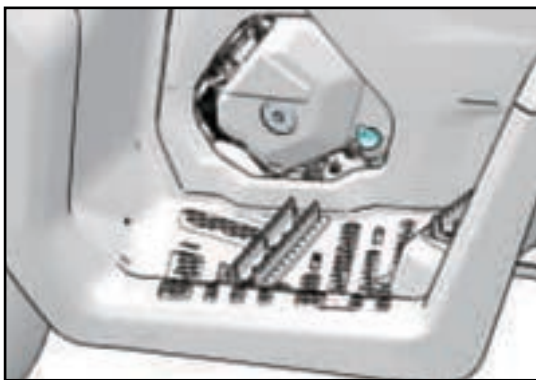
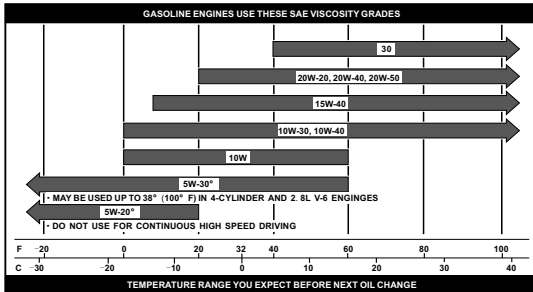

ENGINE OIL LEVEL CHECK

IMPORTANT

Running the engine with an incorrect oil level may result in serious engine damage.

Oil type:

SAE10W-40/SN or higher

Oil level check

- 【A】 Oil dipstick
- 【B】 Upper scale
- 【C】 Lower scale

1. Park the vehicle on a level surface with the engine stopped.

The engine oil dipstick is located above the left pedal side of the vehicle.

2. Unscrew the dipstick and pull it out.
3. Wipe the dipstick clean and reinsert it, then remove it and check the oil level.
4. Check the oil level as shown below: upper scale and lower scale. The oil level between the upper scale and the lower scale is the proper oil level, below the lower scale indicates that the oil quantity is too low, above the upper scale indicates that the oil quantity is too low.
5. After cleaning the dipstick, pump it in again and tighten it.
6. If the oil level is close to or below the lower level mark, add the proper amount of oil.

Oil level check after engine maintenance (oil change)

IMPORTANT

This procedure is only for the first oil level check after a new car or engine service (oil change).

NOTE

During cold weather operation, checking for elevated oil levels may indicate a buildup of crankcase contaminants such as gas or moisture, and if the oil level exceeds the upper limit mark, change the oil immediately.

ENGINE OIL EMISSIONS

Always change the engine oil and oil filter at regular intervals.

Replacement intervals or replacement mileage are available in the Weekly Maintenance Schedule. Change the oil and oil filter at the times given in the Periodic Maintenance Chart.

⚠ WARNING

Change the oil filter when you change the oil.

Hot oil can cause skin burns. Do not allow hot oil to come in contact with your skin.

The engine oil drain plug is located at the bottom of the vehicle engine.

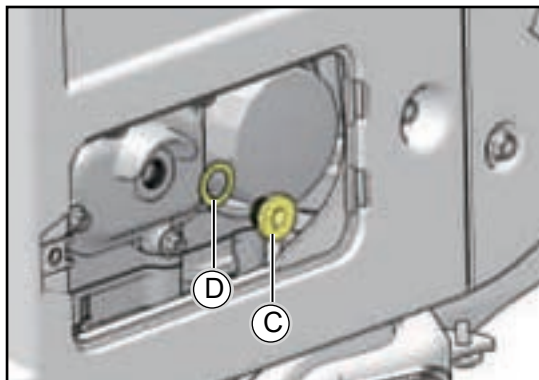
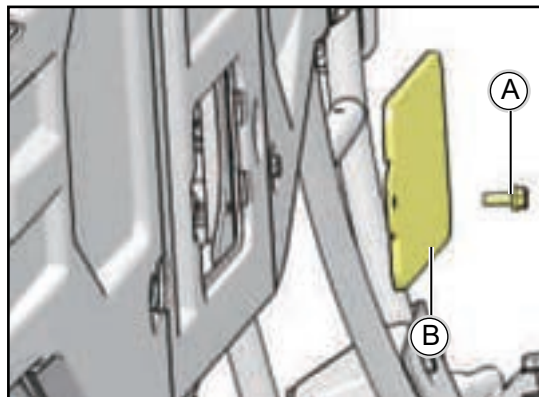
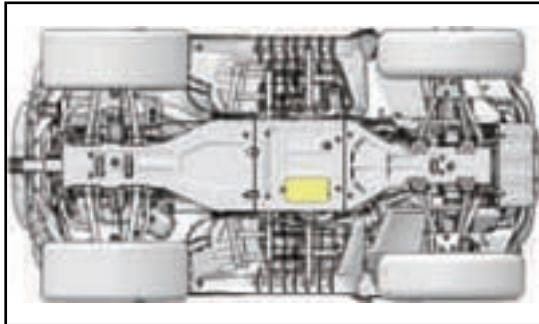

- 【A】 Bolt M6×16
- 【B】 Frame bottom plate maintenance cover plate
- 【C】 Oil drain plug
- 【D】 Copper washer 14×21×1

1. Place the vehicle on a level surface.
2. Start the engine and let it warm up for two to three minutes at idle time.

⚠ WARNING

The used oil and filters must be disposed of in a safe and environmentally compliant manner.

3. Remove the underframe maintenance cover.
4. Place a suitable container underneath the oil drain plug to collect the discharged used oil.
5. Remove the oil drain plug, take off the copper washer and wait for the used oil to be completely discharged.
6. Place a suitable container under the oil drain plug to collect the discharged used oil.
7. Wait for the used oil to be completely discharged.
8. Install the copper washer and oil drain plug in place.

Drain plug torque

16-20N.m(11.8-14.8ft·lb)

CLEANING THE FILTERS

IMPORTANT

Clean the filter at every oil change.

Clean the oil filter before changing the engine's oil, which is located behind the filter cover.

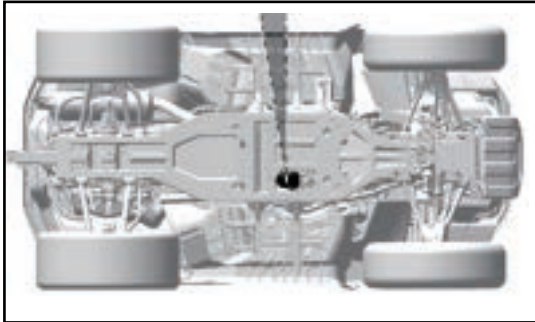

- 【A】 Screw M6*25
- 【B】 Strainer cover
- 【C】 Sealing ring
- 【D】 Screen spring
- 【E】 Oil filter screen

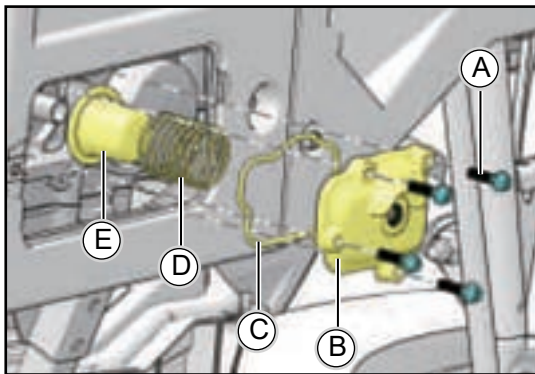

To clean the oil filter screen after draining the oil, perform the following procedure:

1. remove the 4 bolts on the screen cover with a tool.
2. Remove the O-ring seal and screen spring.
3. Remove the oil filter and place the oil filter in the wash jets for cleaning. Wash and dry the oil filter.
4. Reinstall the oil filter with a new o-ring.

Screw M6*25

10 N•m

CHANGING THE OIL FILTER

The oil filter is located under the filter access cover.

- 【A】 Oil filter

1. Remove the frame bottom panel service cover by removing the screws and placing a towel under the oil filter.
2. Remove the oil filter with an oil filter wrench.
3. Replace the o-ring with a new one, lubricate it with oil and install it on the new filter.
4. Tighten the new filter to the specified torque.

oil filter

12 N•m

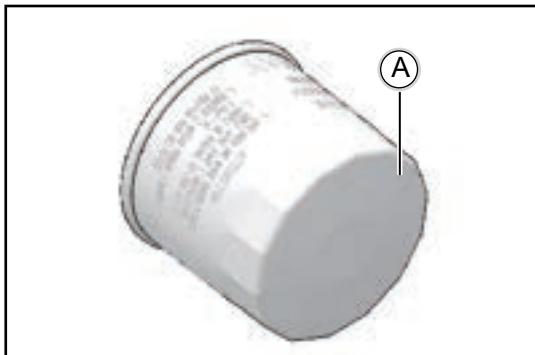

FILLING THE ENGINE OIL

Engine oil can be filled from the dipstick.

Add the proper amount of recommended engine oil, do not overfill.

Oil type:

SAE10W-40/SN or higher grade

Oil capacity:

2200mL



1. Unscrew the dipstick and fill with the proper amount of the recommended type of oil.
2. Retighten the dipstick.
3. place the shifter in park.
4. Lock the parking brake.
5. Start the engine and let it idle for 1 to 2 minutes.
6. Stop the engine.
7. Check for leaks.

ENGINE/FUEL TANK HOSE INSPECTION

The engine and fuel tank are equipped with vent hoses. Check for possible kinks or damaged, cracked air hoses. The hose is molded for proper installation.

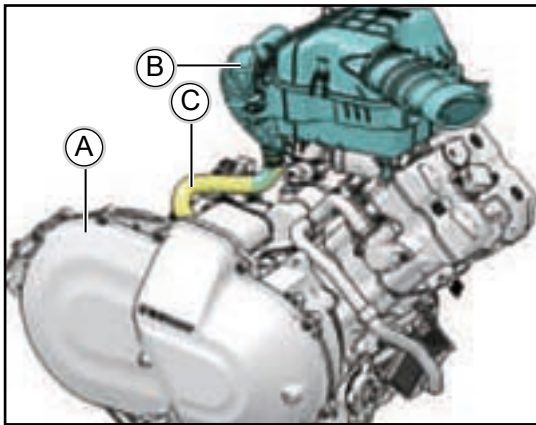

- 【A】 Engine
- 【B】 Air filter
- 【C】 Engine exhaust pipe
- 【D】 Fuel tank
- 【E】 Injector nozzle end high-pressure oil pipe
- 【F】 Breathing valve vent pipe
- 【G】 Oil pump end high-pressure oil pipe
- 【H】 Throttle valve disconnecting pipe
- 【I】 Carbon canister desorption pipe
- 【J】 Adsorption tube

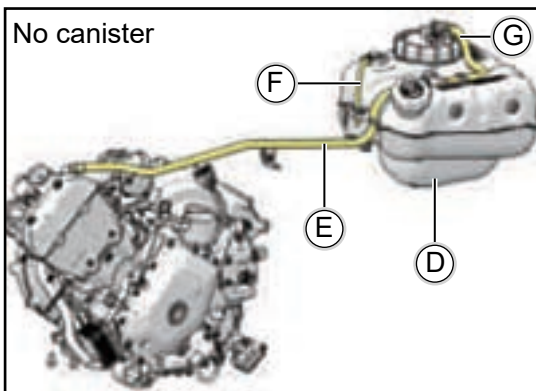

Engine Exhaust Gas Hose: Extends along the engine to the bottom port of the air filter.

Injector End High Pressure Hose: Extends from the engine along the frame main tube to the fuel tank inlet.

Fuel tank vent hose: extends vertically down the fuel tank.

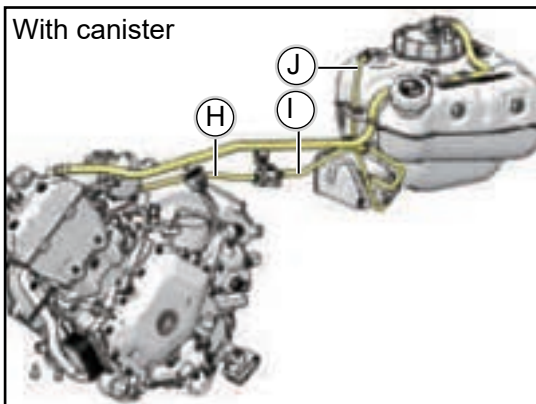

⚠ CAUTION

Make sure the hose is not kinked or crushed.

ENGINE CYLINDER LEAKAGE TEST

Cylinder leakage testing is the best indication of engine conditions. Follow the tester manufacturer's manufacturer's instructions for cylinder leakage testing. Never use a high pressure leak tester with high pressure tester, such as crankshaft seal movement and leakage.

Cylinder leakage service limits:

20%.

If leakage exceeds service limit, check engine for cause.

VALVE LASH CHECK

⚠ CAUTION

Valve lash should be done at room temperature on a cold engine.

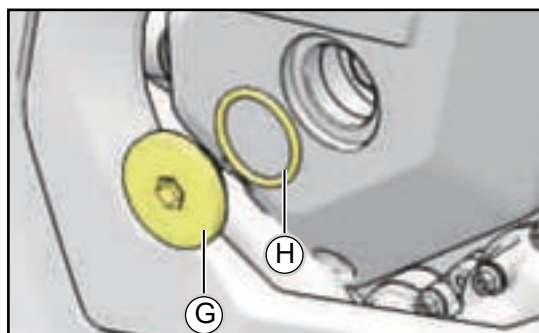
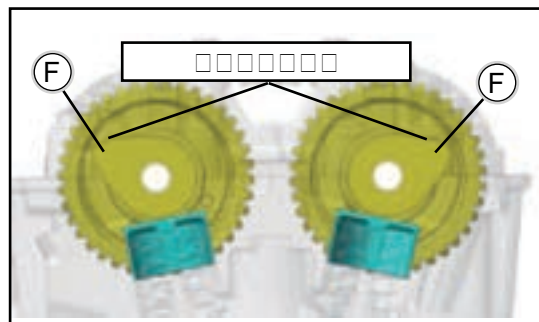
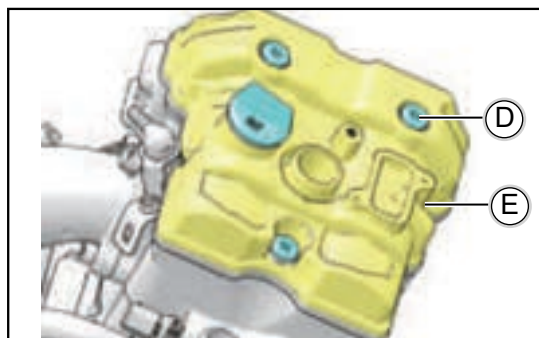
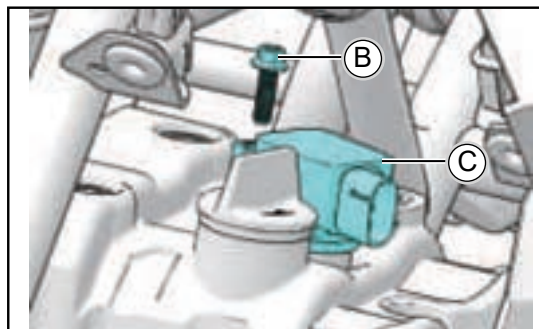
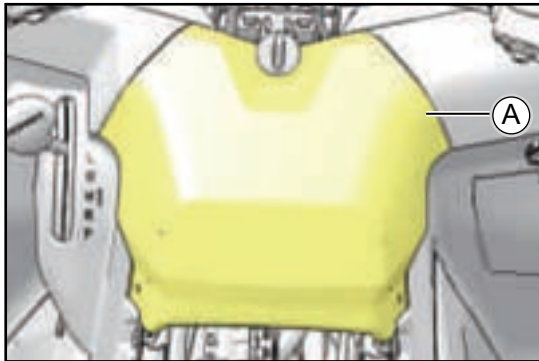

1. 1. Remove the seat cushion and disconnect the negative (-) battery cable.
2. 2. Remove the air filter cover and air filter.
3. 3. Remove the ignition coil by unbolting the ignition coil with a tool.
4. 4. Remove the spark plug with the spark plug socket included in the kit.
5. 5. Remove the 3 hexagon socket head cap screws **【D】** securing the cylinder head cover. Remove the cylinder head cover **【E】**.
6. 6. Check whether the cam peach tip **【F】** above the valve is facing correctly, if the peach tip is not facing outward, remove the engine sight hole cover and turn the crankshaft for adjustment.

The sight hole cover is located on the left side of the engine.

7. 7. Remove the sight hole cover **【G】** and O-ring **【H】** on the engine.

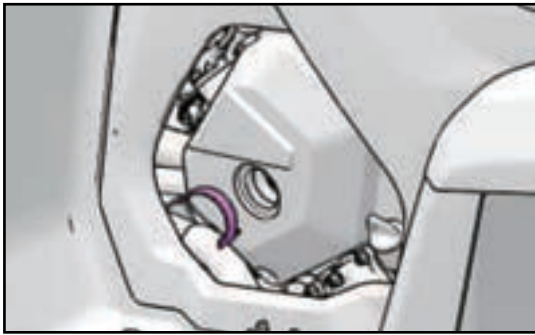

8. Rotate the engine crankshaft with the socket until the cam above the valve to be measured is facing the correct direction. The tip of the peach wheel is facing the correct direction.

9. Measure the valve lash **【A】** and **【B】** with a thickness gauge (plug gauge).

Measuring valve clearance (cold)	
exhaust	0.2 ~ 0.3mm (0.0080" ~ 0.0120")
Import.	0.1 ~ 0.2mm (0.0040" ~ 0.0080")

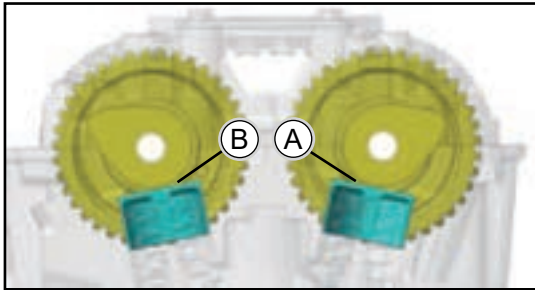

10. If the gap is out of specification, record the measurement.

11. Repeat until all four valves have been checked.

12. To adjust clearance, refer to 3-5-37.

FRONT GEARBOX AND REAR GEARBOX

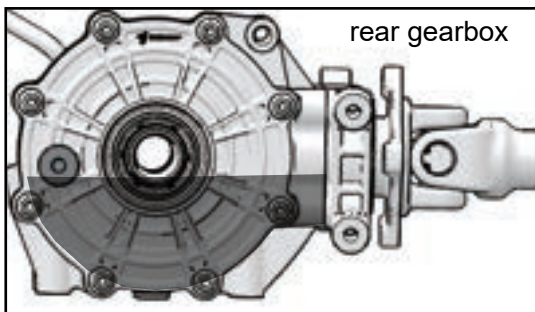

CHECK FRONT AND REAR TRANSMISSION FLUID LEVELS

Front and rear gearbox lubricant levels do not need to be checked under normal conditions, the gearbox level should reach the bottom of the fill hole threads. Change the gearbox oil at the time specified in the Maintenance Interval Table. If the oil level must be checked, perform the following procedure:

- ◆ Prepare a measuring cup and place it under the front (rear) transmission drain plug.
- ◆ Remove the drain plug and wait for the gear oil to drain completely.
- ◆ Check the amount of oil in the measuring cup.

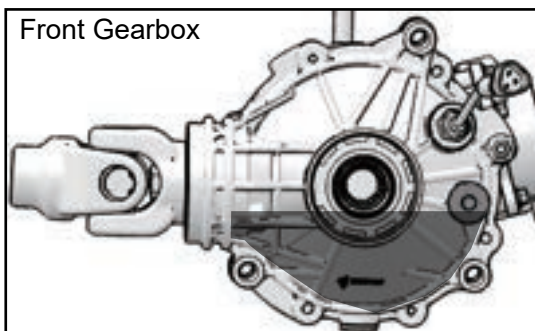

Front gearbox oil volume: 190mL-measuring cup's oil volume=loss of oil volume

Rear gearbox oil volume(non-differential): 140mL - volume of the measuring cup = volume of lost oil

Rear gearbox oil volume(differential): 280mL - volume of the measuring cup = volume of lost oil

FRONT REDUCTION GEARBOX OIL DRAIN

The front reduction gearbox oil drain plug is located at the very bottom of the front reduction gearbox.

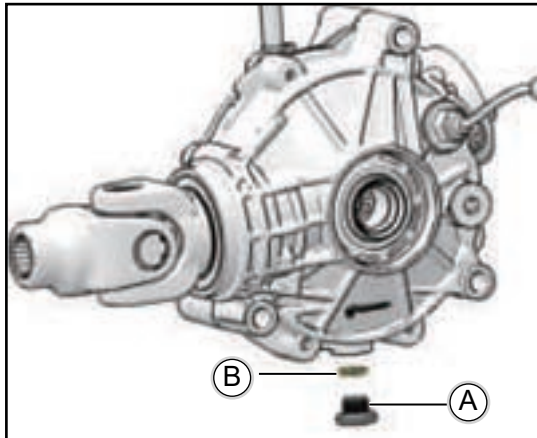

【A】 Oil drain plug

【B】 O-ring

- ◆ Place a container under the drain plug of the front reduction gearbox to collect the discharged waste oil.
- ◆ Place the vehicle on a level surface.
- ◆ Remove the drain plug and O-ring.
- ◆ Wait until the gear oil is completely drained, then clean and install the drain plug, and install a new O-ring.
- ◆ Torque to the required value:

Oil drain plug torque
16-20N.m(1.6-2.0 kgf·m, 11.8-14.8ft·lb)

FRONT REDUCTION GEARBOX GEAR OIL FILLING

The front gearbox filler plug is located on the right side of the front gearbox and can be accessed through the right front wheel side.

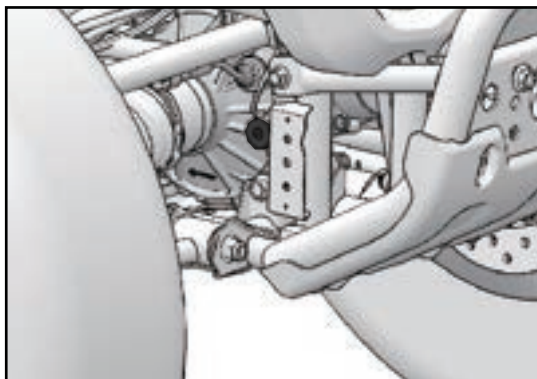

【C】 Filler plug

【D】 O-ring

1. Remove filler plug and o-ring.
2. Add the proper amount of recommended fluid

Gear oil model:

SAE 80W-90 GL5

Gear oil capacity:

170 mL

3. Reinstall the filler plug. Tighten to the desired torque value.

Injection Plug Torque
16-20N.m(1.6-2.0 kgf·m, 11.8-14.8ft·lb)

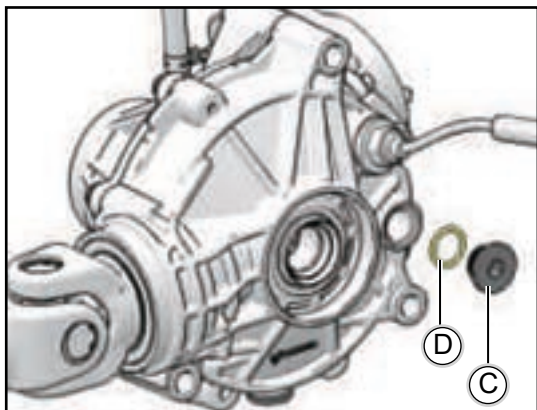

4. Check for spills.
5. Dispose of the discharged waste oil in a reasonable manner in accordance with local requirements.

REAR REDUCTION GEARBOX DRAIN

The rear reduction gearbox oil drain plug is located at the very bottom of the rear reduction gearbox.

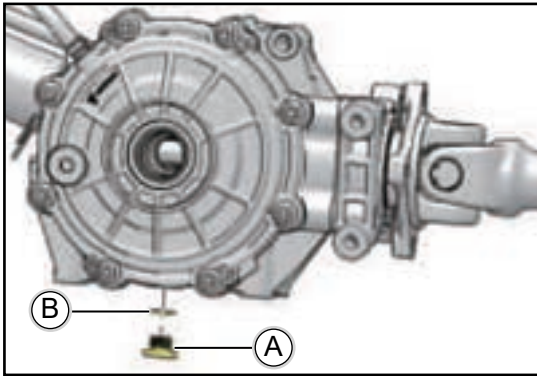

【A】 Oil drain plug

【B】 O-ring

- ◆ Place a container under the rear gearbox drain plug to collect the discharged waste oil.
- ◆ Place the vehicle on a level surface.
- ◆ Remove the oil drain plug and O-ring from the rear gearbox.
- ◆ Wait until the gear oil is completely drained, clean and install the drain plug, and install a new o-ring.
- ◆ The torque reaches the required value:

Drain plug torque

16-20N.m(1.6-2.0 kgf·m, 11.8-14.8ft·lb)

REAR REDUCTION GEARBOX GEAR OIL FILLING

The rear gearbox filler plug is located on the right side of the rear gearbox and can be entered through the rear side of the right rear wheel.

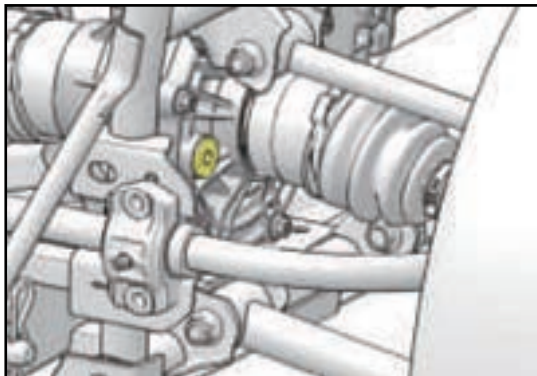

【C】 Filler plug

【D】 O-ring

1. Remove the filler plug and o-ring.
2. Add the proper amount of recommended gear oil.

Gear oil model:

SAE 80W-90 GL5

Gear oil capacity:

120 mL (non-differential)

260 mL (differential)

3. Reinstall the filler plug. Tighten to the desired torque value.

Torque of injection plug

16-20N.m(1.6-2.0 kgf·m, 11.8-14.8ft·lb)

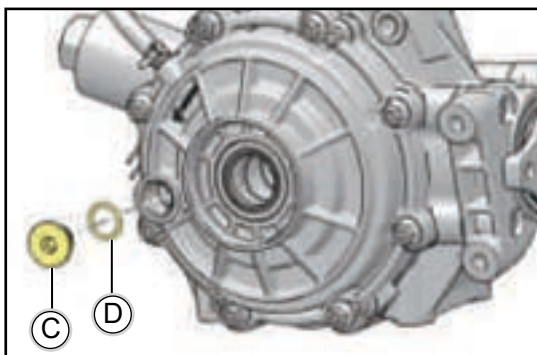

4. Check for spills.
5. Dispose of the discharged waste oil in a reasonable manner in accordance with local requirements.

SHIFT LEVER INSPECTION/ADJUSTMENT



Adjustment of the shift lever may be required if the following conditions

included:

- ◆ No gear on the combination meter
- ◆ Gear noise during acceleration and deceleration
- ◆ Cannot put into gear
- ◆ Excessive gear clearance (noise)
- ◆ Shift lever moved out of desired range

【A】 Upper locknut

【B】 Lower locknut

【C】 Shift lever

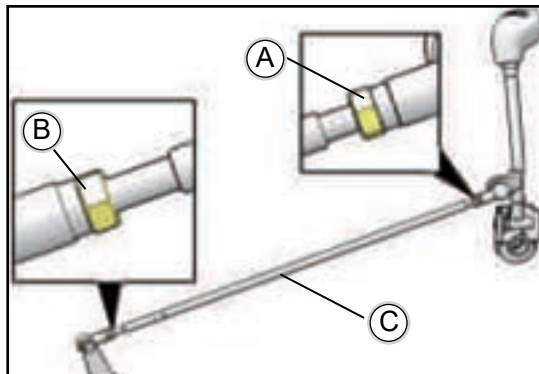

- ◆ Locate the shift lever attached to the frame and to the transmission. Shift on the frame The lock nut 【A】 on the tie rod is located in the inner area under the left front shift lever. The shift lever lower locknut 【B】 on the transmission is located on the left rear foot pedal inboard area.
- ◆ Check the shift lever, upper and lower locknuts and ball joint boots.

Replace if worn or damaged. If adjustment is required, loosen the upper and lower locking nuts to move the shift lever to lock the upper and lower nuts.

- ◆ Adjust the shift lever so that when the engine is in neutral adjust the shift lever threads so that the shift lever centers in the N position on the plastic plate, loosen the shift lever upper and lower locknuts.
- ◆ Screw on or off the lock nut as required for proper tie rod adjustment

NOTE

This process may take a few attempts to get the proper whole.

- ◆ This process may take several attempts to obtain proper adjustment. Once proper adjustment has been obtained, lock the tie rod upper and lower locknuts in place.
- ◆ Start the engine and shift between all gears to make sure the shift lever is correctly adjusted. If the transmission gears are still noisy, the transmission needs to be checked.

COOLING SYSTEM

COOLING SYSTEM OVERVIEW

The engine coolant level is controlled or maintained by the cooling system. The cooling system components are the sub-tank, radiator, radiator pressure cap and connecting hoses.

As the operating temperature of the coolant rises, it expands (heats up), and excess coolant is pushed out of the radiator through the pressure cap and into the sub-tank. As the engine coolant temperature decreases, the coolant shrinks (cools) and enters the radiator through the pressure cap from the sub-tank. The radiator.

⚠ CAUTION

The coolant level is normal to drop in a new car because the system is removing air from the machine. Observe the coolant level frequently during break-in.

If air is not completely removed from the cooling system, the engine may overheat.

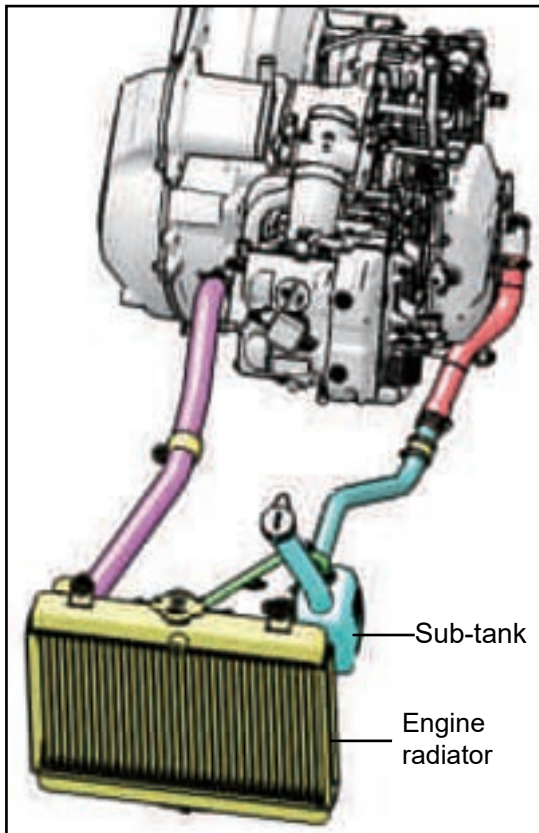

COOLING SYSTEM HOSES

High pressure in the radiator hose can cause coolant leakage **【A】** or hose breakage cracked, (if the line is not connected) to be properly maintained. Visually inspect the hose for signs of damage. Squeeze the hose. the hose should not be hard and brittle, nor should it be soft or swollen.

If there is wear, cracks **【B】** or bulging **【C】**, replace the hose with a new one.

Check that hoses are securely connected and clamps are properly tightened.

Check all radiator hoses for cracks, deterioration, wear or leaks. Replace as necessary.

Check all hose clamps for sealing and securing hose clamps. Replace if necessary.

Check all engine hoses for cracks, deterioration, wear or leaks. Replace as necessary.

Check all hose clamps for sealing and securing hose clamps. Replace if necessary.

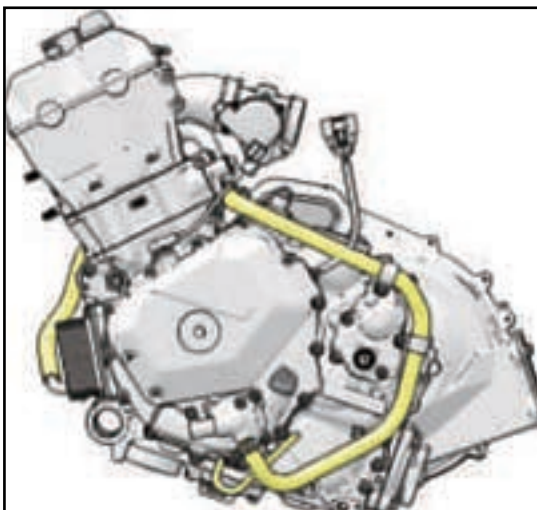
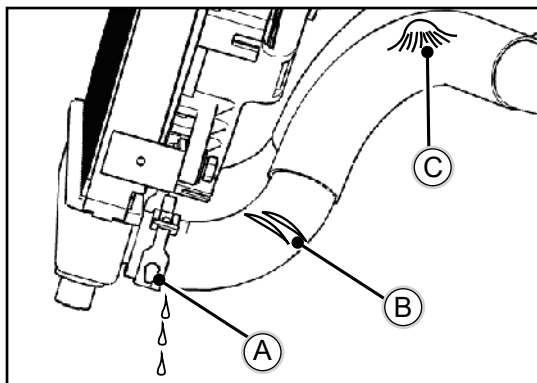

RADIATOR CHECK

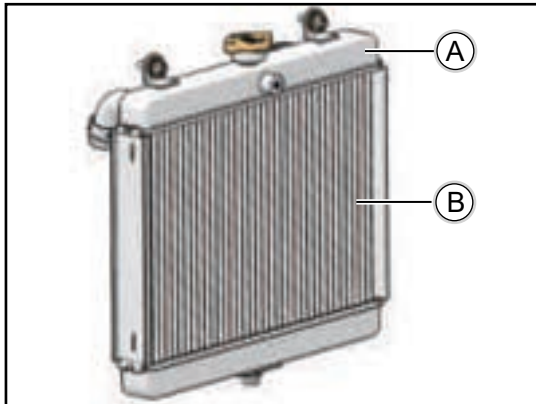

- ◆ Check the radiator air passages for blockage or damage or obstructions.
- ◆ If the corrugated fins **【A】** are deformed, carefully straighten them.

【A】 Radiator

【B】 Corrugated fins

- ◆ Remove obstructions with low-pressure compressed air or low-pressure water.

⚠ CAUTION

Washing the vehicle with a high-pressure water gun may damage the radiator fins and affect the radiator's cooling effect.

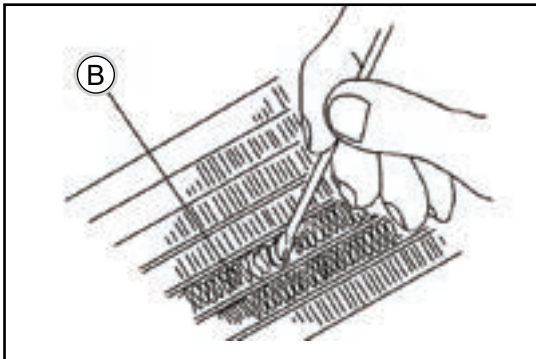

COOLANT BOTTLE COOLANT LEVEL CHECK AND REFILL

The coolant bottle is located above the front left wheel of the vehicle.

- ◆ Observe the coolant level in the coolant sub-tank from the front left side of the vehicle.
- ◆ If the level is low, add coolant. Keep the coolant level at the minimum and maximum marks on the bottle (liquid cooling).

【A】 Maximum

【B】 Minimum

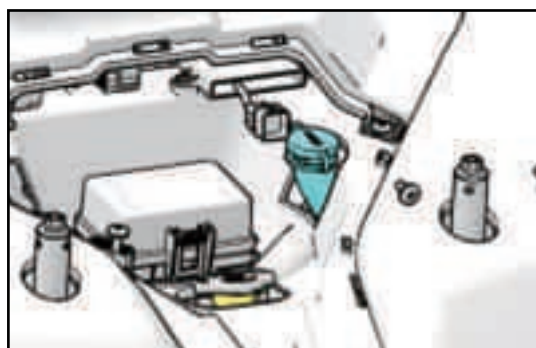
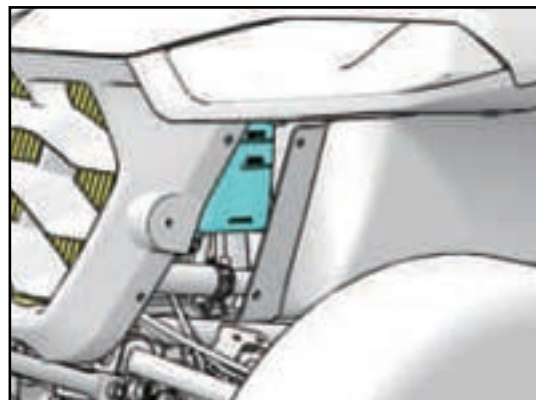

The sub-tank coolant filler is located under the front access cover.

1. Remove front rack
2. Remove the quick release front access cover.
3. Unscrew the cap and pour in fresh coolant. Observe the coolant level during pouring Do not exceed the maximum level.
4. Reinstall the front access cover and front rack.

COOLANT REPLACEMENT

To ensure that the coolant maintains its ability to protect the engine, we recommend that the system be completely drained and a new antifreeze 50/50 premix added every two (2) years.

⚠ CAUTION

Steam spillage can burn the skin. Do not remove the pressure cover when the engine is warm. Remove the pressure cap. Allow engine to cool before removing pressure cap.

When any cooling system fluid is drained and serviced or repaired, replace the coolant with fresh antifreeze 50/50 premix. If the recovery bottle has run dry, check the fluid level in the radiator. Add coolant as needed.

【A】 Pressure cover

【B】 Engine water inlet hose

【C】 Water pump cover

1. Remove the front rack and front access cover.
2. Slowly remove the pressure cap to relieve cooling system pressure.
3. Place a drain pan under the water pump.
4. Remove the left foot pedal, slide the clamp back and remove the water outlet hose **【B】** from the water pump cover to drain the coolant from the cooling system.
5. Allow coolant to drain completely and dispose of used coolant properly.
6. Reinstall coolant hoses and hose clamps.
7. The cooling system must be vented before filling the coolant. See "page 3-23" for procedures.
8. Using a funnel, slowly add the recommended coolant through the radiator fill port (pressure cap). When adding the recommended coolant, observe the level in the coolant bottle and keep the coolant level between the minimum and maximum marks on the bottle (liquid coolant).
9. Reinstall the pressure cap. Use of a non-standard pressure cap will affect the proper functioning of the recovery system. Qualified parts are available from your dealer.

Coolant Model:

**Permanent antifreeze
(green, soft water 50%, cooling water 50%)**

Coolant Capacity:

3300mL

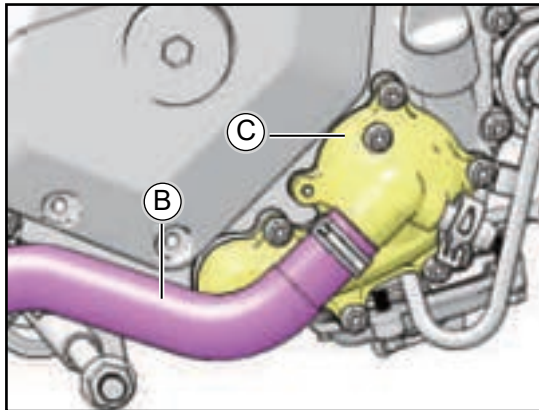
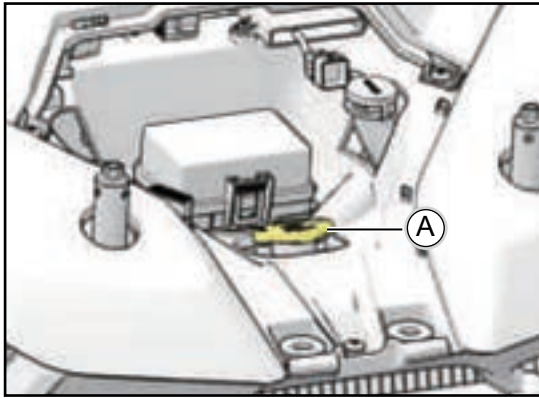

INTAKE AND EXHAUST MAINTENANCE

AIR FILTER

The air filter element is a paper air filter element. The air filter needs to be replaced after a certain period of time. In extremely dusty conditions, the air filter needs to be changed more frequently.

- ◆ The air filter is located under the air filter cover.

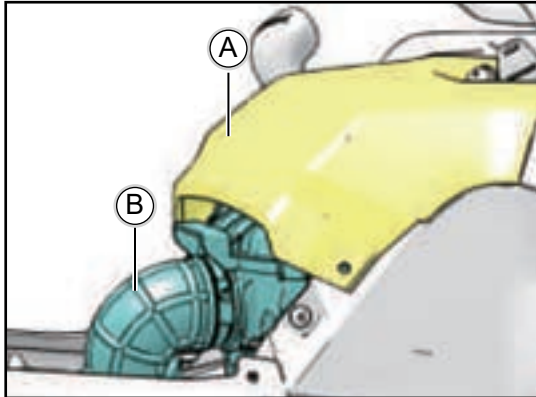

- 【A】 Air filter cover
- 【B】 Air filter assembly
- 【C】 Clip
- 【D】 Air filter upper housing
- 【E】 Filter element

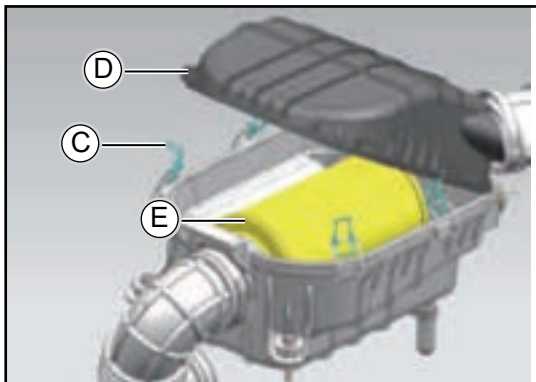

1. Remove the seat cushion and remove the air filter cover.
2. Lift the air filter cover off by removing the four tabs on the upper housing of the air filter.
3. Remove the air filter cartridge housing.
4. Remove the cartridge from the cassette and replace the cartridge for cleaning or replacement.
5. Reinstall the cartridge on the filter.
6. Reinstall the air filter upper housing and air filter cover.

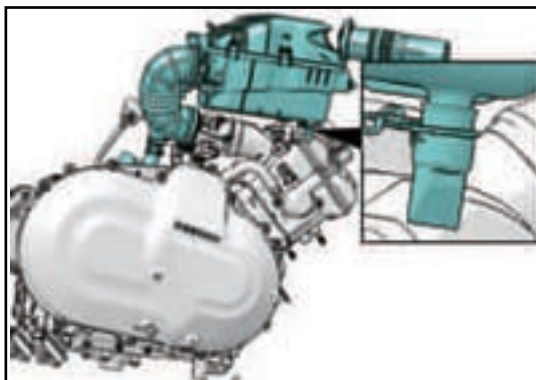

AIR FILTER DRAIN CHECK

Check the air filter drain at each filter element change.

Service the air intake system drain.

Check the drain opening to make sure it is not clogged with debris so that it drains properly.

If necessary, remove the leak plug under the drain opening to drain.

SPARK ARRESTOR

Spark arrestors prevent random sparks from igniting other combustibles. Regular maintenance can prevent carbon buildup. deferred maintenance can reduce engine performance.

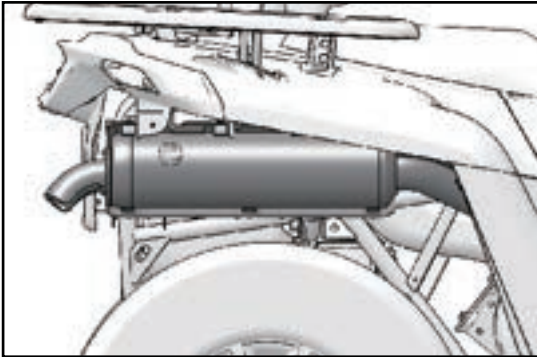

⚠ WARNING

- ◆ Make sure the exhaust pipe is cool. The engine has just stopped working and can burn your skin due to overheating of the exhaust pipe.
- ◆ To reduce the risk of fire, ensure that no combustible materials are in the area at the time of removal.
- ◆ The use of safety glasses is recommended in this procedure.

It is important to remove the buildup of dirt in the exhaust pipe for periodic carbon emissions, as shown below:

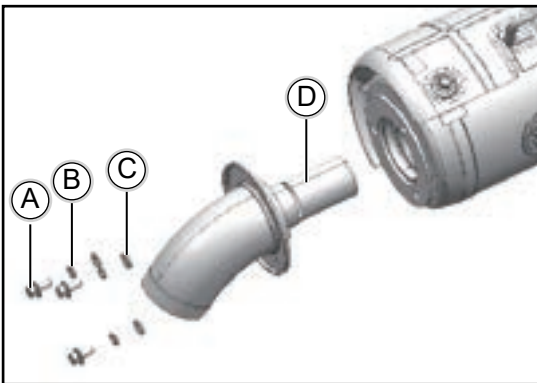

- 【A】 Pan head screws M6×12
- 【B】 Spring washers
- 【C】 Flat washers
- 【D】 Spark extinguisher

1. Remove the 3 fastening bolts.

Torque of fastening bolts
11N.m(8ft·lb)

2. Remove spark arrestor.
3. Clean the spark arrestor with a brush. If necessary, use compressed air to blow debris from the screen.
4. Check the screen for wear and damage. If the screen is worn or damaged, replace it.
5. Reinstall muffler spark arrestor and tighten screws.

EXHAUST HEAT SHIELD INSPECTION

IMPORTANT

Check the exhaust heat shield to make sure it is in good condition and has been secured.

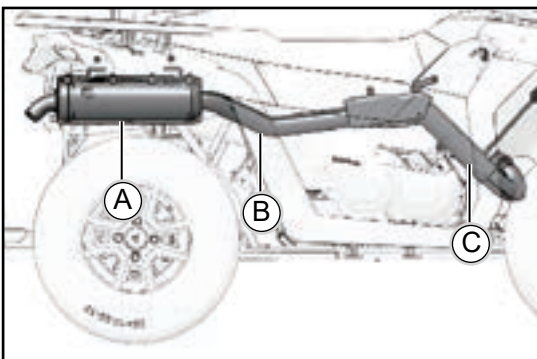

- 【A】 Muffler barrel heat insulation plate
- 【B】 Upper and lower heat shield of exhaust pipe rear section
- 【C】 Heat shield in front of the front exhaust pipe

FUEL SYSTEM AND AIR INTAKE

FUEL SYSTEM

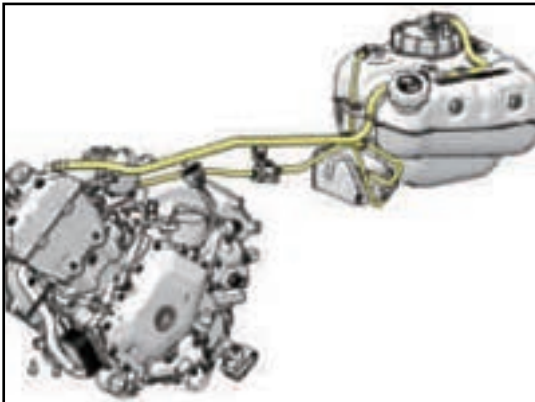

⚠ WARNING

Gasoline burns easily under certain conditions

- ◆ You must be extremely careful when dealing with gasoline.
- ◆ When refueling, the engine must be shut off and must be done outdoors or in a well-ventilated area.
- ◆ At or near the refueling or gasoline storage place. No smoking, no open flames or sparks.
- ◆ Do not overflow when refueling. Do not fill the tank to the neck.
- ◆ If gasoline gets on your skin or clothes, wash them with soap and water immediately and change clothes.

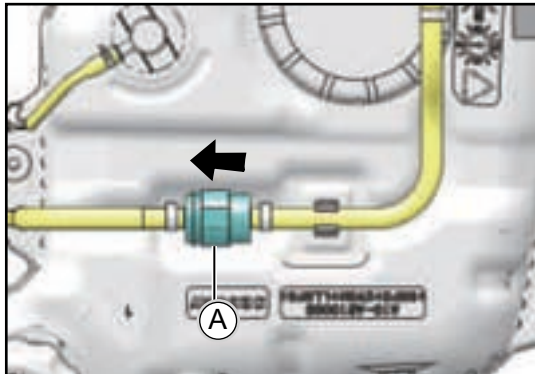

FUEL FILTER

Symptoms of a restricted fuel tank vent include the following: dented and distorted fuel tank, engine malfunction or stalling, reduced engine performance, or excessive exhaust gas temperatures high exhaust temperatures.

【A】 Fuel filter assembly

【B】 Carbon canister solenoid valve

The fuel filter is located under the seat cushion and is visible when the seat cushion is removed.

- ◆ Locate and inspect the fuel filter. Note the direction of the arrow on the filter (if removed).
- ◆ If there is visible debris in the filter, replace it.

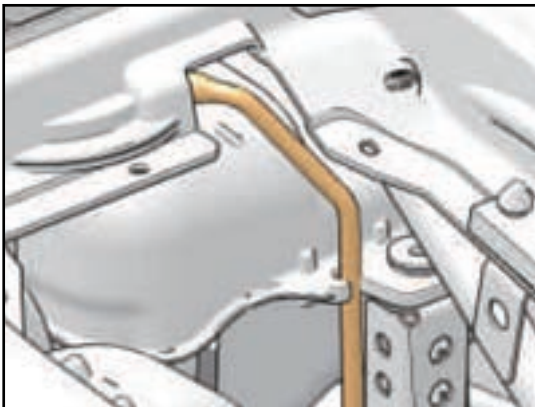

⚠ CAUTION

Be sure to install the filter in the direction shown (see left)

- ◆ Check the fuel tank vent line for signs of wear, cracks or damage. If necessary, replace the vent tube as necessary.
- ◆ Ensure that the ventilation ducts are correctly arranged and that the cable ties are secured.

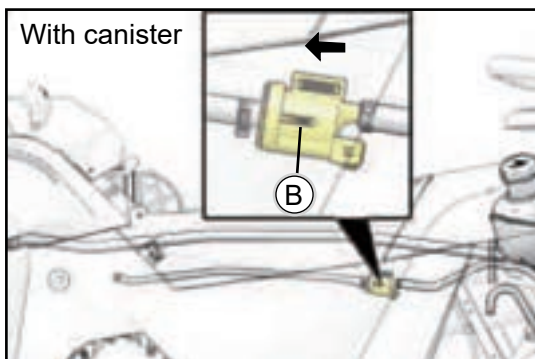

IMPORTANT

Make sure there are no kinks or crushes in the vent hose.

FUEL LINE

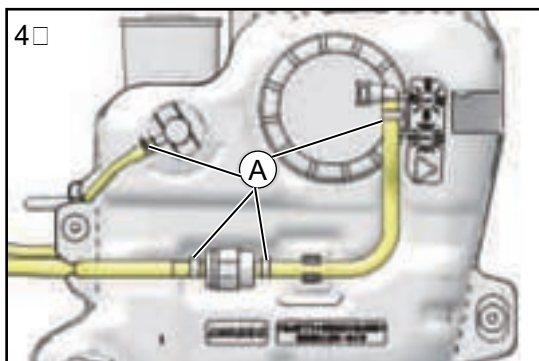

- 【A】 Fuel tank 4 joints
- 【B】 Throttle disconnect fitting
- 【C】 Injector end high-pressure fuel hose connector

First check the piping connections on the tank for leaks, wear, deterioration, damage, etc. Replace fuel lines if necessary. Inspect the fuel lines connecting the engine to the fuel tank for signs of wiring and quick connects for signs of failure wear, deterioration, damage or leaks. Replace if necessary, connect lines. Inspect the throttle disconnect hose that connects the fuel tank to the engine, check the lines and quick connects for signs of trouble wear, deterioration damage, or leaks. Replace and connect lines if necessary.

- ◆ Ensure fuel lines are properly laid out and secured.

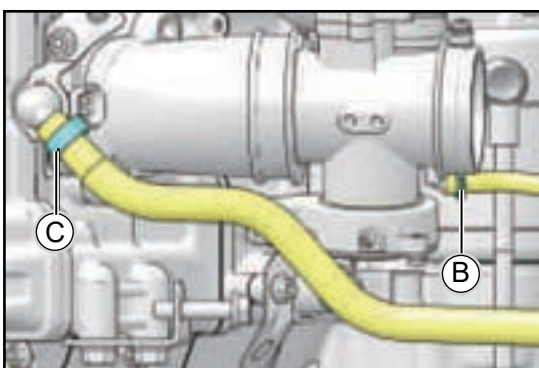

IMPORTANT

Make sure lines are not twisted or pinched.

CVT

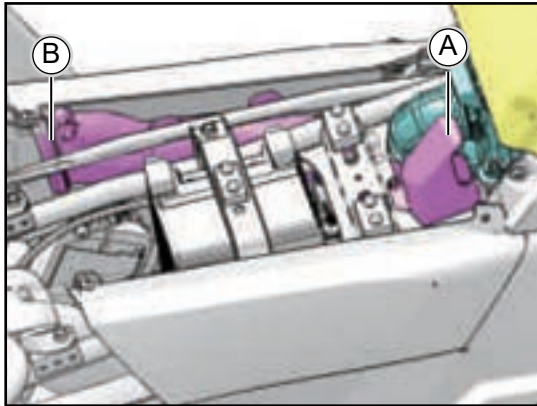

CVT INTAKE SCREEN CHECK

It is recommended that the CVT air intake filters be checked periodically and the following procedure should be followed:

There are 2 CVT air intakes, both located under the seat cushion.

- 【A】 Air inlet 1
- 【B】 Air inlet 2

Clean the CVT air intake filter screen
 Replace with a new air inlet filter if necessary

CVT BELT

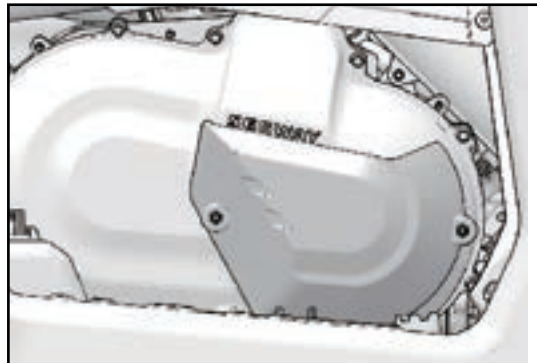

Replace the CVT drive belt at the time specified in the vehicle maintenance schedule. If the CVT belt is damaged, replace it as well.

⚠ WARNING

Failure to remove all debris when replacing the belt could result in vehicle damage, loss of control and serious injury or death.



Stop the vehicle engine and allow the vehicle to cool sufficiently before replacing.

1. First remove the right guard of the vehicle.
2. Remove the CVT heat shield on the CVT.
3. Remove the CVT outer cover bolts and remove the CVT outer cover and CVT cover sealing ring
4. with the follower wheel top lever (special) against the hole of the follower wheel as shown in the figure, so that the the follower wheel disk open.

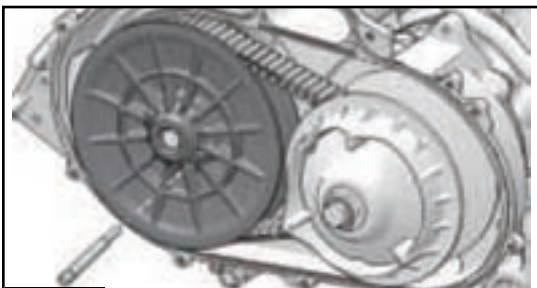

⚠ CAUTION

Before removing the drive belt, note the direction of the marks on the drive belt (e.g., manufacturer's name, arrow mark, etc.) so that the drive belt can be reinstalled on the pulley in the original direction.



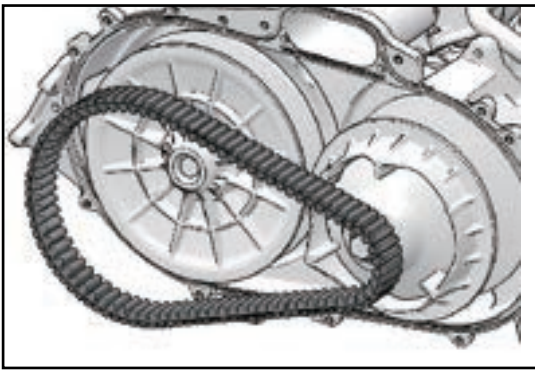

5. Remove the drive belt to be replaced and clean any debris from the CVT compartment.

INSTALLATION OF DRIVE BELTS

⚠ CAUTION

Make sure the new belt orientation is the same as the original belt installation.

Installation steps are essentially the reverse of those for removal.

1. Wrap the drive belt around the CVT master and follower pulleys.
2. Pull out the driven pulley top lever and tighten the CVT driven pulley disk.
3. Install the CVT seal and tighten the CVT outer cover.

CVT outer cover bolts

10 N•m (1 kgf•m, 80 in•lb)

DRY CVT

There are some instances where water can accidentally soak into the CVT system, before driving the vehicle dry it first.

1. Remove the clutch drain plug.
2. Wait for the water to drain and reinstall the drain plug.
3. Place the transmission in "P" and pull up the parking handle.
4. Start the engine.
5. Use varying throttle openings for 10-15 seconds to expel moisture and air, dry the belts and CVT, do not hold the throttle fully open for more than 10 seconds.
6. Allow the engine speed to remain at idle speed, apply the brake, and shift the transmission to the lowest available range.
7. Belt slip test, if belt slips, repeat process.
8. If the vehicle needs service, contact your Segway dealer to provide you with assistance.

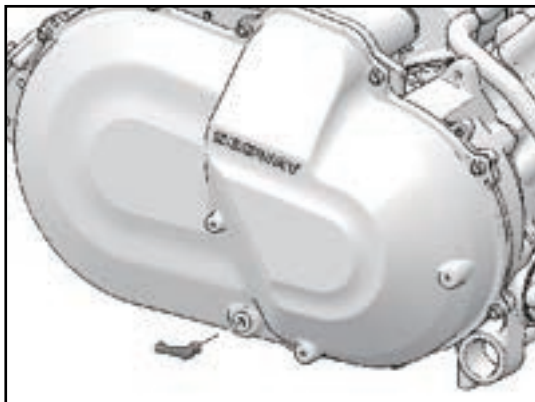

DRIVE SHAFT MAINTENANCE / TIRES

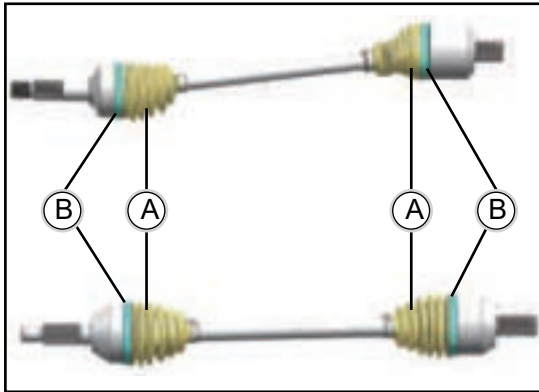

DRIVE SHAFT DUST SLEEVE INSPECTION

Inspect the front and rear driveshaft dust boots **【A】** for cuts, damage or grease leaks. If the dust boots show any of these symptoms, they should be replaced. Check dust boot clamps **【B】** for proper positioning.

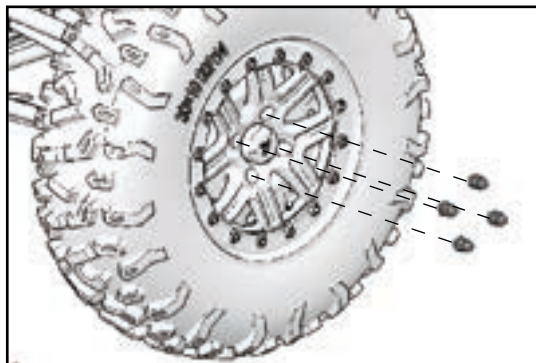

WHEEL PARTS REMOVAL

1. Stop the engine.
2. Place the shift lever in the "P" position and lock the parking brake.
3. Loosen, but do not remove, the four wheel mounting nuts with a tool.
4. Raise the side of the vehicle with jack support in a suitable location.
5. Remove the rim mounting nuts.
6. Remove the entire wheel.

	front wheel	rear wheel
Recommended Tires Size	24×8.00-12	24×10.00-12
	25×8.00-12	25×10.00-12

WHEEL MOUNTING

For tire mounting as opposed to removal, tighten the 4-piece tire mounting nuts to the specified torque value.

Wheel Mounting Nut
70~80 N.m

⚠ CAUTION

Always use wheels of the same size as recommended in the Service Manual or it may result in loss of vehicle control.

⚠ CAUTION

Do not lubricate bolts or nuts.

TIRE TREAD DEPTH

Check the tire tread block wear, when the tire tread block wear is at least 1.6mm above the tread, the tire should be replaced.

! WARNING

Operating with worn tires increases the likelihood of vehicle skidding and possible loss of control. Worn tires can cause accidents. When tire tread wear reach the limit, always replace the tires.

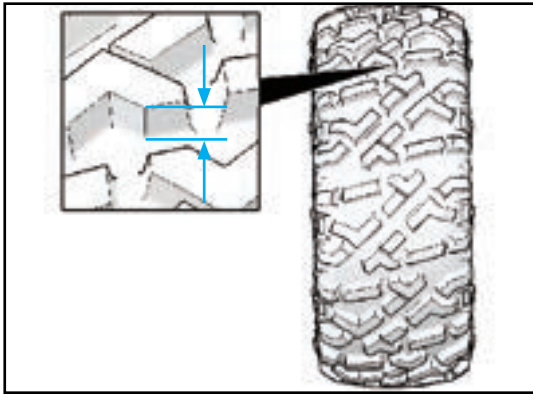

TIRE PRESSURE CHECK

When checking tire pressure, follow these steps

	front wheel	rear wheel
tire pressure	7.0psi (48.3kPa)	7.0psi (48.3kPa)

Tire Pressure Checking Guide, please observe the following when checking tire pressure:

- ◆ Inspect the tires only after they have cooled down.
- ◆ If the vehicle has been parked for at least 3 hours or has not been driven for more than 1.5km (kilometers), then checking at this time will give an accurate cold tire inflation pressure reading.
- ◆ Check tire pressure with a tire pressure checking device or the tire pressure gauge in your vehicle's tool kit.
- ◆ It is normal for tire pressure to increase after driving, do not lower the tire pressure.



STEERING MAINTENANCE



STEERING SYSTEM CHECK

Steering system components should be checked periodically for loose fasteners, worn tie rod ends/transverse tie rod fasteners, loose steering shaft universal joints, and tie rod ball wear.

Replace any worn or damaged steering parts. The steering should travel the full range of travel of free movement with no sticking. Check all cables, hoses and wiring of the wiring to ensure that the steering mechanism is not restricted.

NOTE

Check front beam alignment when replacing steering components.

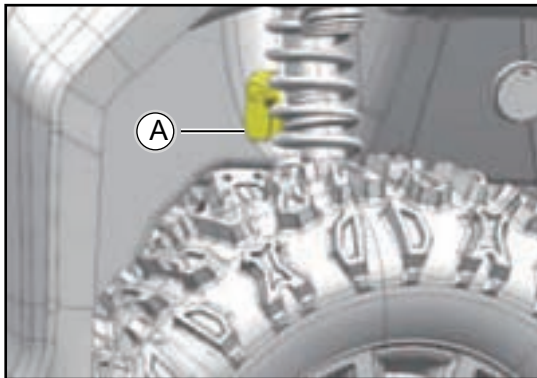

POWER STEERING (EPS MODELS)

【A】 Power steering

Removing the right front inner fender allows access to the power steering unit through the right front wheel cover.

Clean the area around and on top of the power steering unit frequently for proper cooling.

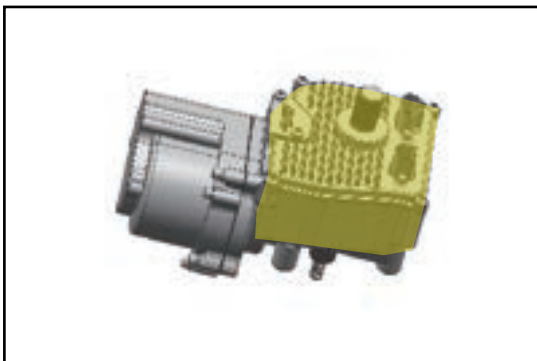

NOTE

After riding in muddy conditions, be sure to thoroughly clean these areas

TRANSVERSE TIE ROD INSPECTION

NOTE

Whenever you replace a steering component, check the front beam for alignment

- ◆ To check the clearance of the transverse tie rod **[A]**, grasp the transverse tie rod and pull it in all directions to feel if there is any movement.
- ◆ Replace any worn or damaged steering parts. The steering should move freely throughout the entire travel range without sticking.
- ◆ Lift the front end of the vehicle so that the front wheels are off the ground, checking for a loose front wheel/hub assembly by grasping first the top and bottom of the vehicle's front wheels, then the front and rear of the vehicle's front wheels. Try pushing inward and pulling outward to move the wheel and hub.
- ◆ If abnormal movement is detected, inspect the hub and wheel assembly to determine the cause. cause (Loose wheel mounting nuts or loose front hub nuts.)

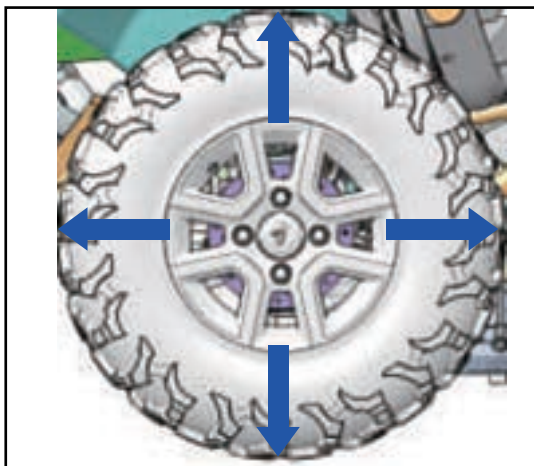
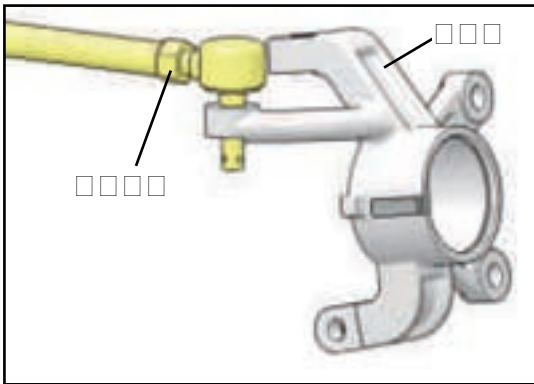
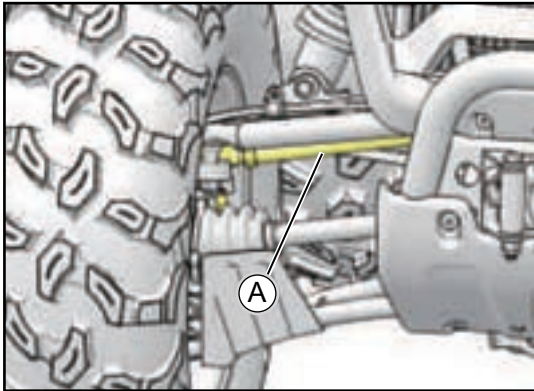

ANTERIOR BEAM CHECK

- ◆ Front beam means that the distance between the front ends of the two front wheels is less than the distance between the rear ends at the height of the axle. The difference in distance is called the front beam value. When there is a front beam, the distance A (rear) is greater than B (front) when looking down from the top of the car, as shown in the figure.
- ◆ The function of the front beam is to prevent the front wheels from running off at any time and to reduce the sliding friction between the tires and the ground. If the front beam is incorrect, the front wheels will slide against the ground, resulting in tread damage or abnormal wear.

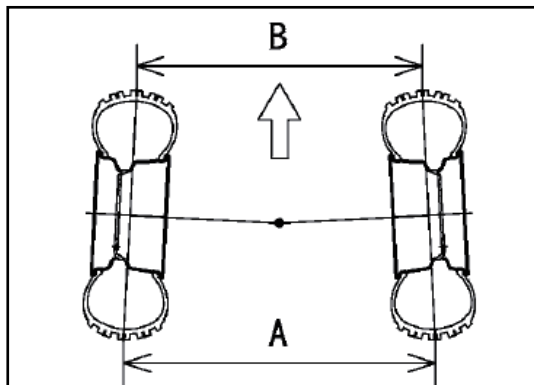

The main pin rear and camber angles are fixed and do not require adjustment.

$$A \text{ (rear)} - B \text{ (front)} = \text{front beam value}$$

(Distances A and B are measured at the height of the vehicle's axle when parked on a flat surface.)

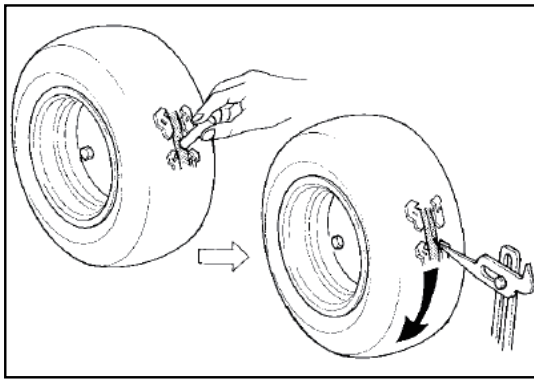

- ◆ Apply a thick line of chalk or paint near the center of the front tire.
- ◆ As you turn the wheel, use a needle tip plotter to make a small mark near the center of the chalk coating.

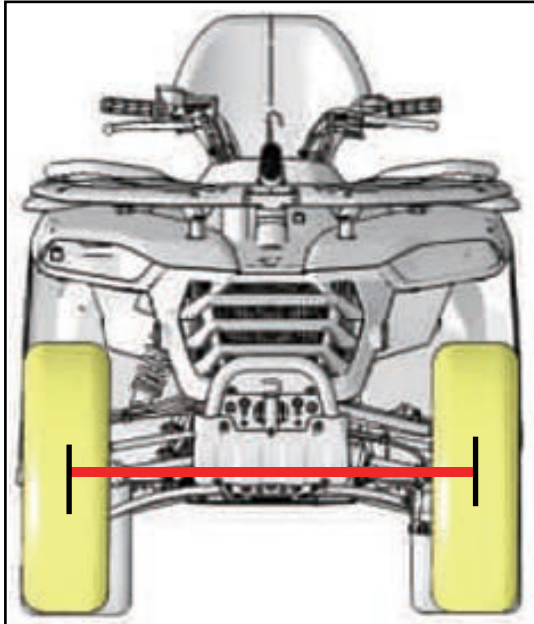

- ◆ Place the front wheels on the ground and turn the steering wheel upright to secure it.
- ◆ At axle height, measure the distance between the front and rear scribed or painted lines of the front tires.
- ◆ Subtract the front measurement from the rear measurement to obtain the front beam.

If the front beam is not within the specified range, continue the front beam adjustment procedure.

Standard: -5 ~ 5 mm

FRONT BEAM ADJUSTMENT

- 【A】 Anti Loosening Nut
- 【B】 Tie rods

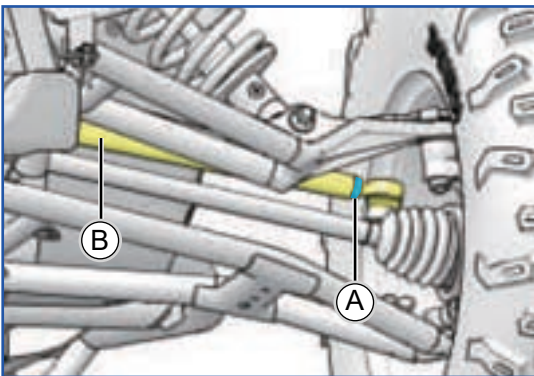

- ◆ Loosen the jam nut 【A】 and turn the adjusting tie rods 【B】 on both sides the same number of turns to achieve the specified front beam.

⚠ WARNING

Adjust the length of the cross tie bar so that the visible threads on the ends of the cross tie bar are of uniform length, A non-uniform thread length can result in damage to the cross tie rod ends.

- ◆ Check the front beam.
- ◆ Tighten:

Cross tie bar adjustment lock nut torque
45 N.m (4.5 kgf·m, 34 ft·lb)

- ◆ Test drive vehicles.

SHOCK ABSORBER

SHOCK ABSORBER INSPECTION

Since the front shock absorbers are sealed units, they cannot be disassembled and only require external inspection. If one unit is damaged, replace both shock absorbers as a set. If only one unit is replaced and both are not balanced, it may cause the vehicle to become unstable at high speeds or the overall comfort deterioration of the vehicle at high speeds.

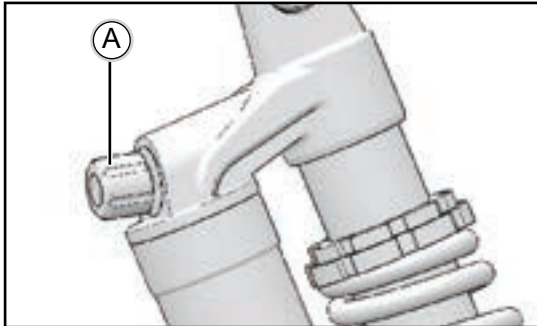

ADJUSTABLE PNEUMATIC SHOCK ADJUSTMENT

Compression Damping Adjustment

【A】 Compression Damping Adjustment Adjustment Knob

- ◆ Turn the knob clockwise to increase the shock absorber compression damping.
- ◆ Turn the knob counterclockwise to decrease the compression damping of the shock absorber.

Spring Preload Adjustment

Adjust the upper spring end cap with a special tool

- ◆ Adjusting the end cap downward increases the spring preload.
- ◆ Decrease the spring preload by adjusting the end cap upward.

【A】 Lock nut 【B】 Adjustment nut

【C】 Spring preload position

- ◆ Screw the lock nut 【A】 to the desired position, and then unscrew the adjusting nut 【B】 , adjust the nut position 【C】 .

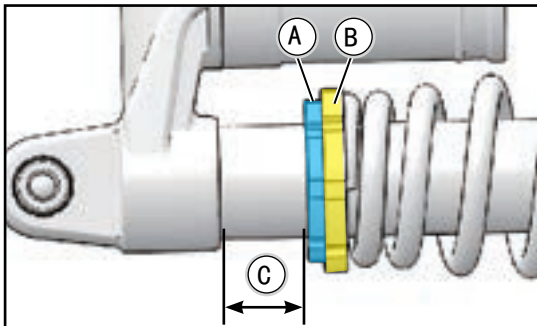

Spring preload position 【C】 setting

Standard: Front shock absorber 36mm(1.42in.).

Usage range: 16mm(0.63in.)~56mm(2.20in.).

Rear shock absorber 43mm(1.69in.)

Operating range 23mm(0.91in.)~63mm(2.48in.)

Spring Lock Nut Torque

30 N·m

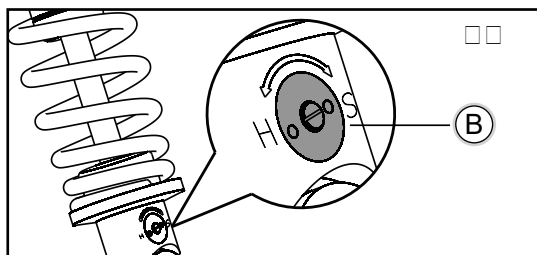

Recovery Damping Adjustment

【B】 Recovery damping adjustment valve (I type)

Rotate the restoration damping adjustment valve with a word up

- ◆ Turning in the "H" direction increases the damping.
- ◆ Turning to the "S" direction, the restoration damping decreases.

The restoration damping regulator has 12 positions, and the factory setting is the 6th position.

Tools: 【C】 Screwdriver

【C】 Restoration damping adjustment valve (II type)

- ◆ Turning in the "S" direction increases the damping.
- ◆ Turning in the "F" direction decreases the damping.



OIL SHOCK ABSORBER ADJUSTMENT

The damping has 5 positions for different loads or driving conditions.

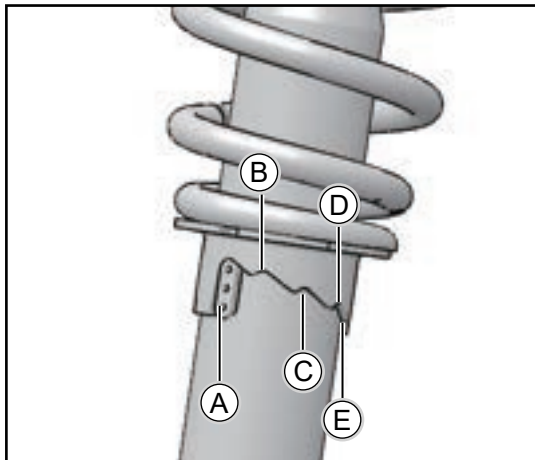

position	sprung	environment	load	topography	speed
↑	soft	soft	Light	smooth	low
standard position	↑	↑	↑	↑	↑
↓	hard	hard	Heavy	bumpy	high

Position **【A】** : Standard position.

Position **【B】 【C】 【D】 【E】** : According to the vehicle load, speed increase, the

Gradually adjust



Use the hook wrench **【F】** (in the supplied tool bag) to adjust the shock spring pressure.

⚠ CAUTION

When adjusting the shock absorbers, always adjust both the left and right shock absorbers to the same position. gradually adjust upward or downward one position at a time. Do not attempt to make large adjustments as this may damage the shock absorbers.

BRAKING SYSTEM

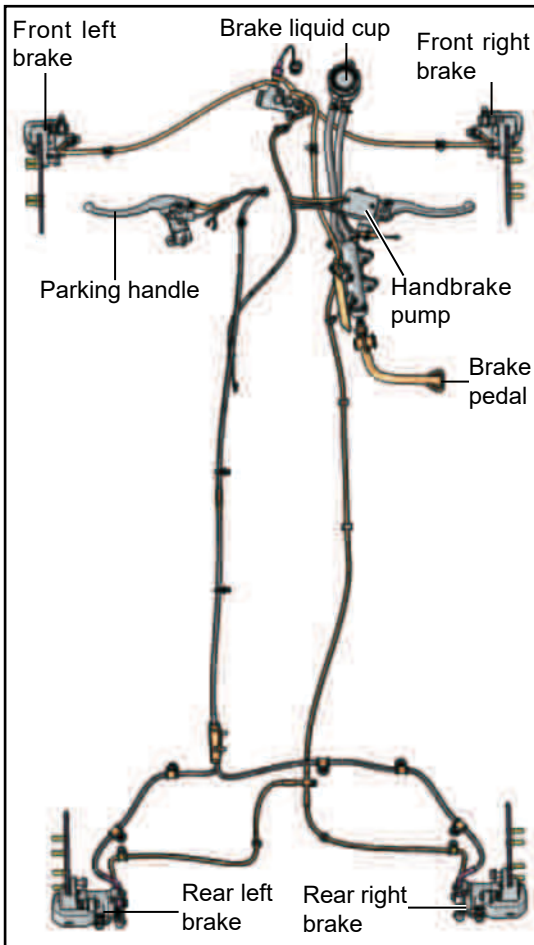

Front and rear brakes are hydraulic disc brakes, activated by the brake pedal

! WARNING

The brake fluid level must be checked periodically:

An overfilled brake cylinder may cause brake resistance or brake lock-up, which could result in serious injury or death. Keep the brake fluid at the recommended level and do not overfill. Brake Discs Brake discs must be checked for periodic wear: If the brake discs are worn, they should be replaced.

The following checks are recommended to keep the brake system in good working order. If the brakes fails during heavy use in normal operation, it should be checked frequently.

- ◆ Always keep the brake fluid at the proper level. For more information, refer to 2-39.
- ◆ Check for fluid leaks in the brake system.
- ◆ Check that the brake travel is not too long or feels uncomfortably soft.
- ◆ Check for worn, damaged or loose friction pads. Replace the brake pads when the remaining limit, you must replace the brake pads brake pad thickness is not less than 1.5mm.
- ◆ Check the safety and surface condition of the brake disk. Use the recommended brake cleaner to remove all grease. Do not use spray lubricants or other lubrication products. If there is damage (cracks, excessive corrosion, warping), contact your dealer before operation.

BRAKE FLUID LEVEL CHECK ON HANDBRAKE UPPER PUMP

Use the recommended brake fluid:

brake fluid	DOT4
-------------	------

Verify that the handbrake master pump reservoir level is at the specified level.

【LOWER】 Brake fluid cup minimum level mark. .

Check the fluid level through the fluid level sight hole, if it is below the minimum level line

【LOWER】 , check and replenish the brake fluid. .

For replenishing the flow brake fluid in the brake lines, the addition procedure is as follows: :

- ◆ Remove the screw on the brake fluid cup cover of the handbrake pump, and replenish the brake fluid cup with the same grade of brake fluid.
- ◆ Replenish the brake fluid cup with brake fluid of the same grade.

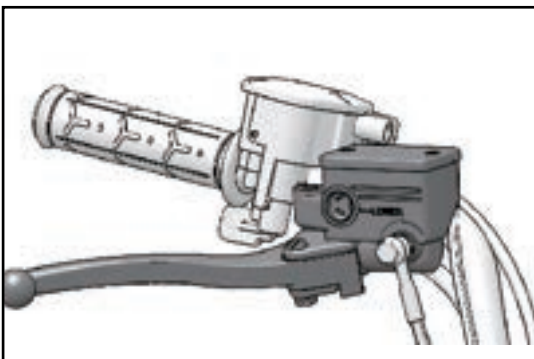

⚠ CAUTION

Brake fluid can damage plastic and painted surfaces, use caution when adding.

If brake fluid comes into contact with skin or eyes, flush immediately with plenty of water.

If there is any further discomfort, please consult a doctor immediately.

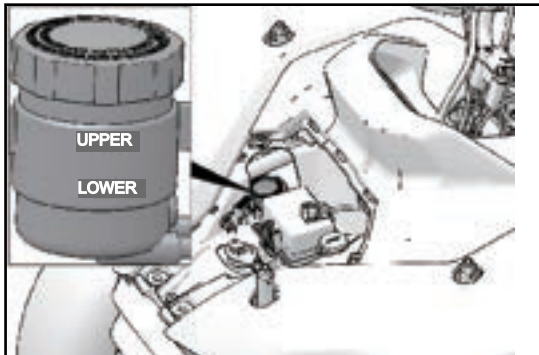

Check brake pads for wear.

BRAKE FLUID CUP LEVEL CHECK

The rear brake oil cup is located between the left front upper inner fender and the front shock absorber.

- ◆ Place the entire vehicle on a level surface and check is the fluid level in the oil cup.

A] - MAX - High level in the brake fluid cup.

[B] - MIN - Minimum level in the brake fluid cup.

- ◆ If the fluid level falls below the minimum level line - LOWER - or below, replenish the brake fluid with the same grade.

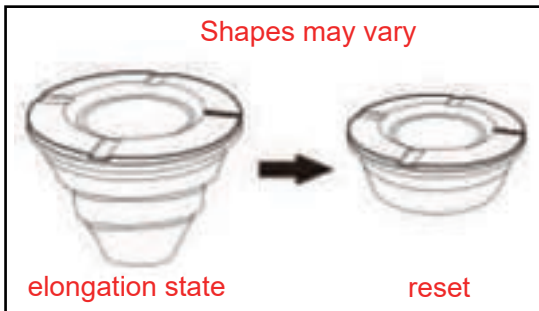

⚠ CAUTION

After replenishing or replacing the brake fluid, check whether the oil cup pad under the oil cup cover is in an elongated state. If the oil cup gasket is elongated, it is necessary to reset the oil cup gasket (as shown in the figure). If the oil cup gasket is not reset, brake fluid will spill out of the oil cup when the oil cup cover is tightened.

- ◆ If the oil cup gasket is stretched, reset the oil cup gasket first.
- ◆ Tighten the oil cup cover.

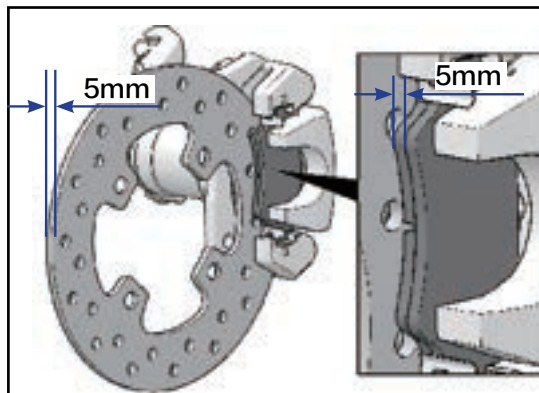

⚠ CAUTION

Replenish or refill DOT4 brake fluid as required.

BRAKE LININGS AND DISCS

Brake lining and disc wear will depend on the severity of use and driving conditions. Brake linings wear faster in wet and muddy conditions. Check the wear of the brake linings and discs regularly according to the maintenance schedule. If the brake lining and disc are worn beyond the required values, the brake lining and disc must be replaced. (See pages 10-13, 10-14, 10-18, 10-19)

Brake Lining Thickness	Standard thickness	5.0mm
	Minimum thickness	1.5mm
Brake Disc Thickness	Standard thickness	5.0mm
	Minimum thickness	4.0mm

BRAKE PEDAL AIR TRAVEL CHECK

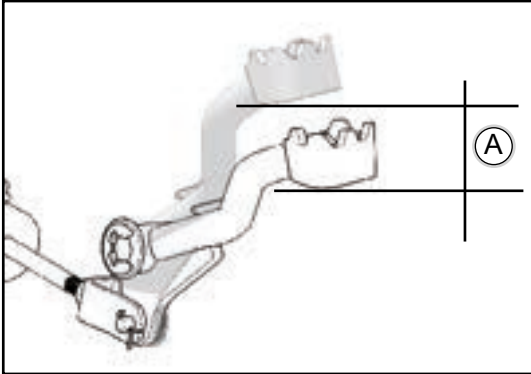

【A】 Brake pedal travel

- ◆ Check the empty travel of the brake pedal 【A】 .
- ◆ Depress the brake pedal gently with your foot until the brake pedal is depressed.

If the rear brake pedal has too much air travel, adjust it, (see chapter "Braking").

Rear brake pedal travel standard:

(2 to 3) mm (0.08 to 0.12 inch)

PARKING HANDLE WORKING STROKE CHECK

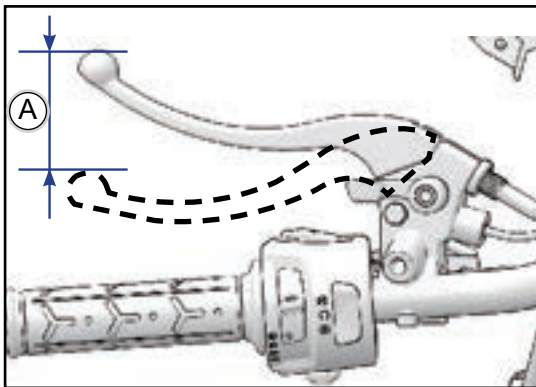

【A】 Parking handle working stroke

- ◆ Check the working stroke of the parking handle 【A】 .
- ◆ Squeeze the parking handle by hand until it is parked.

If the working travel of the parking handle is large, adjust it.

Parking handle working travel standard:

(10 to 20) mm (0.4 to 0.8 inch)

PARKING HANDLE FREE TRAVEL ADJUSTMENT

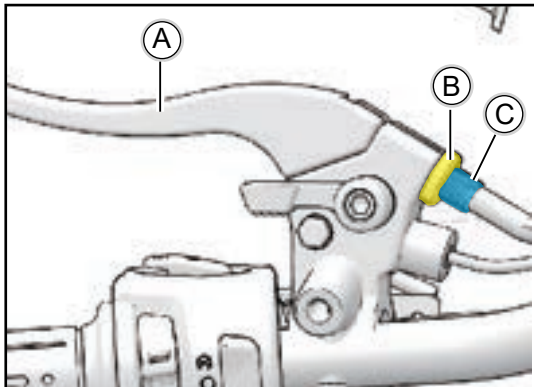

【A】 Brake handle

【B】 Anti Loosening Nut

【C】 Brake lever adjuster

- ◆ Turn the brake lever adjuster to lock the jam nut 【B】 .
- ◆ Tighten the jam nut 【B】 .

until the correct travel is achieved.

ELECTRICAL AND IGNITION SYSTEMS

BATTERY MAINTENANCE

Keep battery terminals and connections free of corrosion, if cleaning is required, use a stiff wire. If cleaning is required, remove corrosion with a stiff wire brush, clean with a solution of one tablespoon of baking soda and one cup of water, rinse well with tap water, dry with a clean towel, lubricate with dielectric grease or vanadium. Rinse well with tap water, dry with a clean towel, and grease the terminals with dielectric grease or petroleum jelly. Apply dielectric grease or petroleum jelly to the end.

⚠ WARNING

12V batteries contain toxic and corrosive sulfuric acid, skin contact may result in burns.

If the solution in the battery accidentally splashes on your eyes, skin or clothes, please wash them immediately with plenty of water and seek medical advice promptly.

Batteries can produce explosive gases, so keep away from sparks, flames, cigarettes, etc..

Always charge the 12V battery in an open area. Do not charge the 12V battery in a poorly ventilated garage or closed room.

Always wear eye protection when working near the battery.

BATTERY REMOVAL

⚠ CAUTION

If the electrolyte spills, immediately rinse off a solution of one tablespoon of baking soda and one cup of water with clean water to prevent damage to the vehicle.

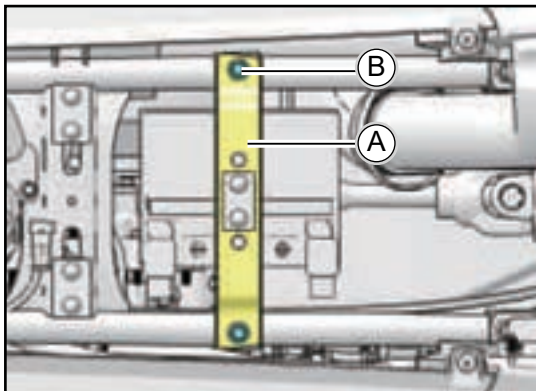

The battery is located under the seat cushion. To replace or maintain the battery, perform the following steps.

Turn off the vehicle power before removing the battery

【A】 Battery pressure plate

【B】 Hexagonal flange bolts M8×16

1. Remove the driver's seat cushion.
2. Holding the groove behind the battery guard with your hand your hand moves forward to move the
3. Remove the 2 bolts securing the battery pressure plate.
4. Roll up the protective rubber sleeve.
5. Remove the negative battery screw and disconnect the black (negative) battery cable.

6. Remove the positive battery screw and disconnect the red (positive) battery cable.
7. Remove the battery from the vehicle

BATTERY INSTALLATION

⚠ CAUTION

To reduce the possibility of sparking: each time the battery is removed, disconnect the black (negative) cable to reconnect. When reinstalling the battery, install the black (negative) cable last.

cable last when reinstalling the battery.

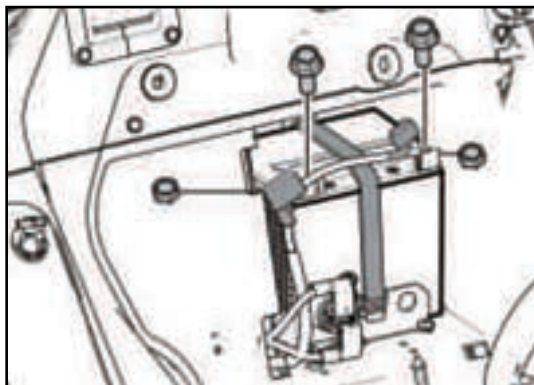

1. Clean battery cables and terminals with a stiff wire brush. Corrosion can be removed with a cup of water and a solution of one tablespoon of baking soda to remove it. Rinse well with water and dry thoroughly. Rinse with clean water and dry thoroughly.
 2. Place the battery in the tray.
 3. Connect and tighten the red (positive) cable and return the insulating rubber boot to its place.
 4. Connect and tighten the black (negative) cable and return the insulating rubber boot to its place.
 5. Attach the battery plates.
 6. Tighten the battery pressure plate bolts.
- Verify that the cables are properly routed.

BATTERY CHARGING

⚠ CAUTION

If charging, the hydrogen gas produced by the 12V battery is a flammable explosive gas. Therefore, observe the following precautions before charging:

- ◆ If charging a 12V battery still installed in the vehicle, be sure to disconnect the ground cable.
- ◆ When connecting and disconnecting the charger cable to the 12V battery, make sure the power switch on the charger is turned off.
- ◆ Charge only slowly (5A or less). If fast charging is used, the 12V battery may explode.

SPARK PLUGS

Refer to the recommended spark plug type and gap specifications. Spark Plug Torque Specifications.

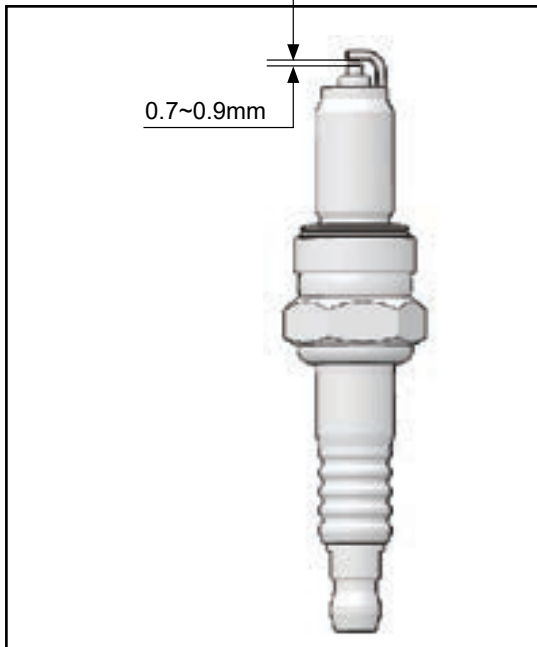

⚠ CAUTION

Using non-recommended spark plugs can cause serious engine damage.

Always use recommended spark plugs or their equivalent.

spark plugs	model number	spark plug gap	Spark Plug Torque
	NGK CPR7EA / TORCH B7RTC	0.7~0.9mm	12 N.m (1.2 kgf·m, 8.8ft·lb)

SPARK PLUG CHECK

Spark plug condition indicates engine operation. Check or refer to the maintenance replacement spark plug Periodic Maintenance Program for the time.

⚠ CAUTION

Hot exhaust systems and engines can cause burns. When removing spark plugs for inspection wear protective gloves.

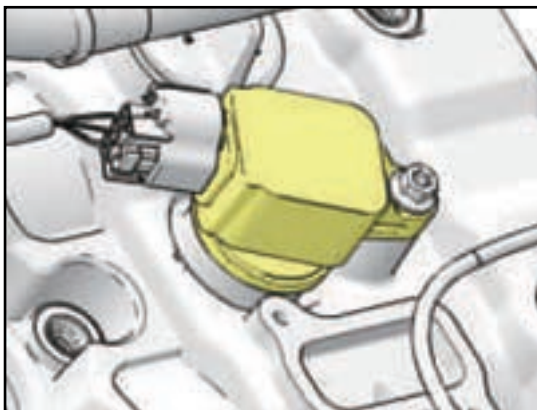

- 【A】 Bolt
- 【B】 Ignition coil
- 【C】 Spark plug
- 【D】 Spark Plug Sleeve

The spark plug is located under the air filter cover

1. remove cushion and air filter cover.
2. Unplug the ignition coil harness and remove the ignition coil retaining bolt.
3. Remove the ignition coil, with the spark plug located under the ignition coil.
4. Using the special wrench for the spark plug in the tool bag, turn the spark plug counterclockwise.

Installation is performed in the reverse order of removal, and tightening is performed to the specified torque.

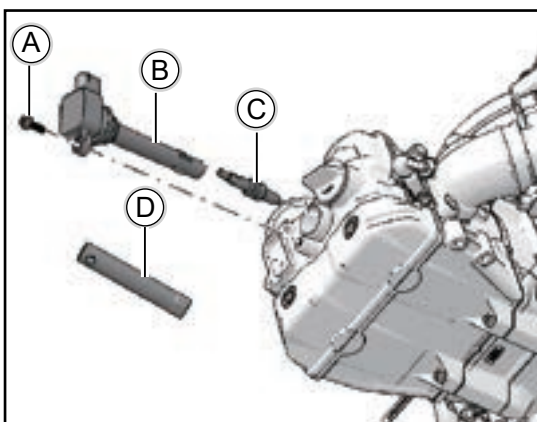

Normal Plug

Normal insulator tips are gray, tan, or light brown. Very little there are burning deposits. The electrodes are not burned or corroded. This indicates that the engine is burning is adequate.

The tip should not be white. A white insulator tip indicates overheating due to use of improper spark plugs or incorrect throttle body adjustment.

need to be replaced

Contaminated insulator tips are black. Moist oil film covers the launching end. The entire head may have a carbon layer. Generally, the electrodes are not worn. A common cause of fouling general cause of fouling is excessive oil, use of unrecommended oil or poor fuel quality.

THROTTLE CABLE FREE TRAVEL CHECK AND ADJUSTMENT

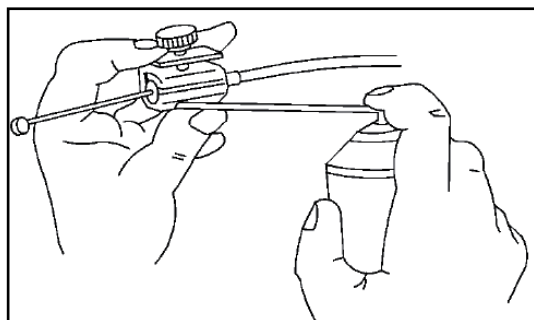
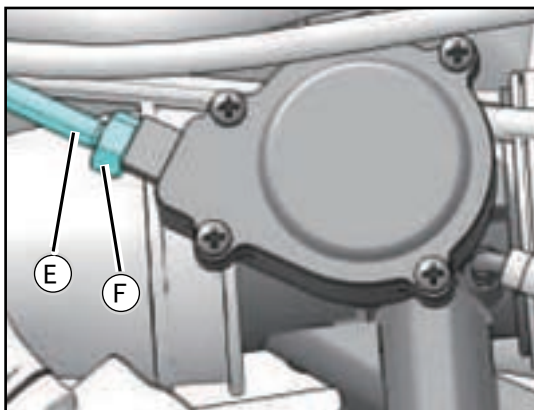
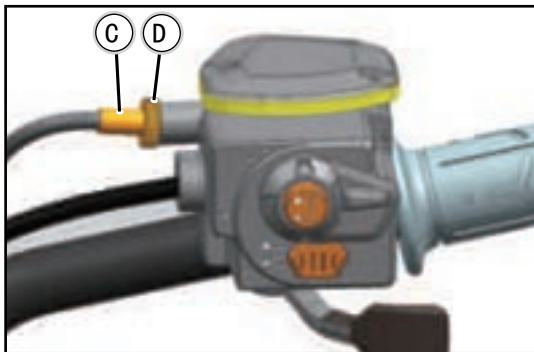
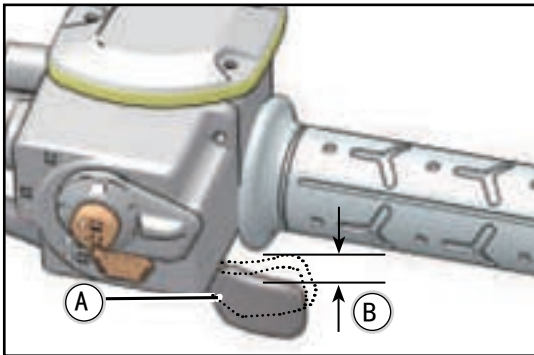

THROTTLE LEVER FREE PLAY CHECK

- 【A】 Throttle lever
- 【B】 Free clearance
- 【C】 Adjuster
- 【D】 Lock nut
- 【E】 Adjusting screw
- 【F】 Lock nut

1. Check that the throttle lever moves smoothly from the fully open position to the closed position, and quickly and completely closes the throttle in all steering positions by means of the return spring door.
2. If the throttle stick does not return correctly, check the wiring of the throttle cable, the free play of the throttle stick and the possibility of damage to the cable, then lubricate the throttle.
3. Run engine at idle speed and turn handle all the way to the left and right to ensure idle speed does not change. Make sure idle speed does not change.
4. If idle speed increases, check throttle lever free play and cable routing.
5. Stop the engine and check the throttle stick free play. If the free play is not within the specified range, adjust the cable.

Throttle lever free play :

standard: 2 ~ 3mm (0.08 ~ 0.12in.)

6. Slide the rubber cover off the adjuster at the throttle housing.
7. Loosen the lock nut and turn the throttle cable upper adjuster until the cable has proper clearance.
8. Tighten the locknut and reinstall the rubber cover.
9. If it is not possible to adjust the throttle for proper free travel using the upper adjusting screw, remove the plastic part and use the throttle cable at the bottom of the throttle to adjust until it fits, then tighten the locknut.

⚠ CAUTION

Using a throttle not properly assembled for operation may otherwise result in unsafe riding conditions.

- ◆ Check for free play of the throttle stick.

Lubricate door pulls prior to installation.

Improper adjustment can lead to misuse of wiring or cable damage may result in unsafe riding conditions.

ENGINE LUBRICATION SYSTEM

EXPLODED VIEW.....	3-1-2
TECHNICAL PARAMETER	3-1-4
SPECIAL TOOLS AND SEALANTS	3-1-5
ENGINE OIL FLOW CHART	3-1-6
ENGINE OIL AND OIL FILTER.....	3-1-7
OIL LEVEL INSPECTION.....	3-1-7
ENGINE OIL CHANGE.....	3-1-8
OIL FILTER CHANGE	3-1-8
COARSE FILTER REMOVAL.....	3-1-8
OIL PRESSURE.....	3-1-9
OIL PRESSURE MEASUREMENT	3-1-9
OIL PRESSURE VALVE REMOVAL.....	3-1-10
OIL PRESSURE VALVE INSTALLATION.....	3-1-10
OIL PRESSURE VALVE INSPECTION.....	3-1-10
OIL PUMP	3-1-11
OIL PUMP REMOVAL	3-1-11
OIL PUMP INSTALLATION	3-1-11
OIL PUMP GEAR.....	3-1-12
OIL PUMP GEAR REMOVAL.....	3-1-12
OIL PUMP GEAR INSTALLATION	3-1-12
OIL COOLER	3-1-13
OIL COOLER REMOVAL	3-1-13
OIL COOLER INSTALLATION	3-1-13
OIL FILTER REMOVAL	3-1-13
OIL FILTER INSTALLATION.....	3-1-13

EXPLODED VIEW

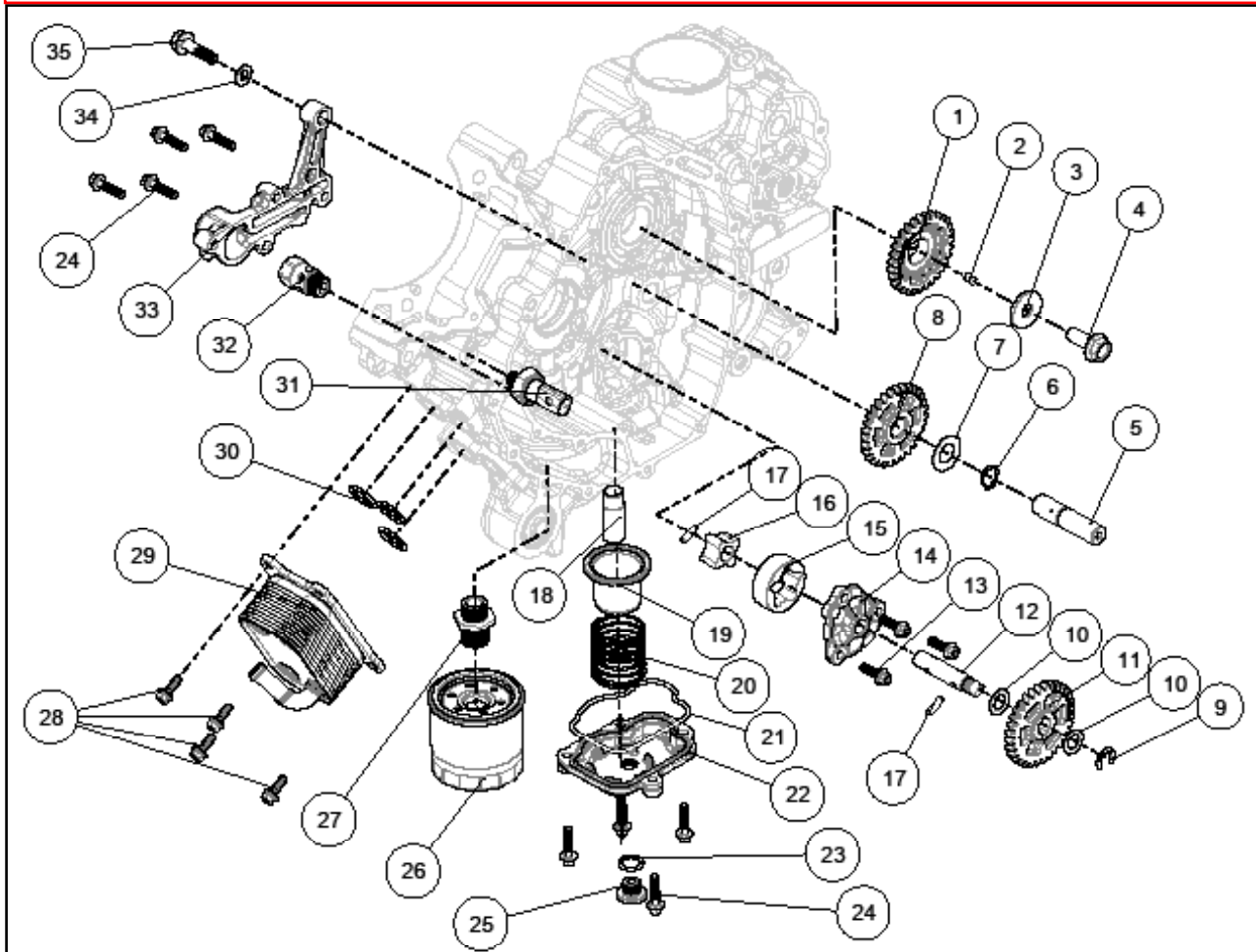

ENGINE LUBRICATION SYSTEM

SEGWAY AT5

NO.	NAME	TORQUE			REMARKS
		N·M	KGF·M	FT·LB	
1	Oil Pump Drive Gear				
2	Flat Key				
3	Spacer				
4	Bolt M10×1.25×25	80	8	58	
5	Oil Pump Idler Gear Shaft				
6	Circlip 15				
7	Spacer 15×28×1				
8	Oil Pump Idler Gear				
9	E-Ring 9				
10	Spacer12×20×1				
11	Oil Pump Driven Gear				
12	Oil Pump Shaft				
13	Bolt M6×20	10	1	7	
14	Oil Pump Cover				
15	Outer Gerotor				
16	Inner Gerotor				
17	Needle Roller 4×15.8				
18	Oil Pickup Pipe				
19	Strainer Filter				
20	Strainer Filter Spring				
21	O-Ring 82×3.1				
22	Strainer Filter Cover				
23	Copper washer				
24	Bolt M6×25	10	1	7	
25	Engine Drain Plug M14	18	1.8	13	
26	Oil Filter	18	1.8	13	R
27	Oil Filter Adapter	40	4	28	L
28	Bolt M6×16	10	1	7	
29	Oil Cooler				
30	O-Ring 19×2.5				
31	Oil Pressure Sensor	15	1.5	11	SS
32	Oil Pressure Valve Unit	22	2.2	16	L
33	Oil Pressure Valve Unit Cover				
34	Gasket 8				
35	Banjo Bolt M8×30	20	2.0	14	

G: Apply grease for oil seal and O-ring.

L: Apply a non-permanent locking agent.

O: Apply engine oil.

SS: Apply silicone sealant.

R: Replacement Parts.

TECHNICAL PARAMETER

Item	Standard
<p>ENGINE OIL:</p> <p>Grade</p> <p>Viscosity</p> <p>Capacity</p>	<p>API SN or Higher</p> <p>SAE 10W-40</p> <p>2.0 L (2.11 US qt) (when filter is not removed)</p> <p>2.2 L (2.32 US qt) (when filter is removed)</p> <p>2.4 L (2.54 US qt) (when engine is completely dry)</p>
<p>Oil Pressure Measurement:</p> <p>Oil Pressure @ 4500 r/min(rpm), oil temp. 110°C(230°F).</p>	<p>400 kPa (4.1 kgf/cm², 58 psi)</p>

SPECIAL TOOLS AND SEALANTS

OIL PRESSURE GAUGE, 10 KG/CM² :



SILICONE SEALANT:

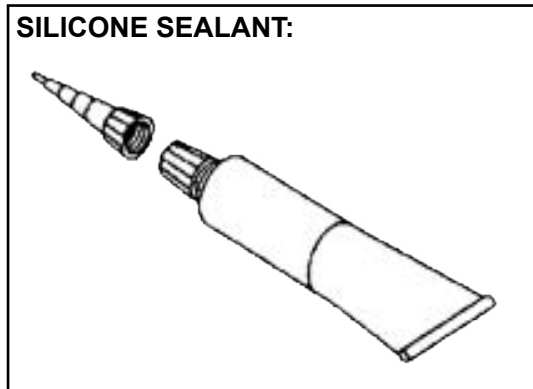

Oil Pressure Test Hose, M10×1:
E01GZ0040001



ENGINE OIL FLOW CHART

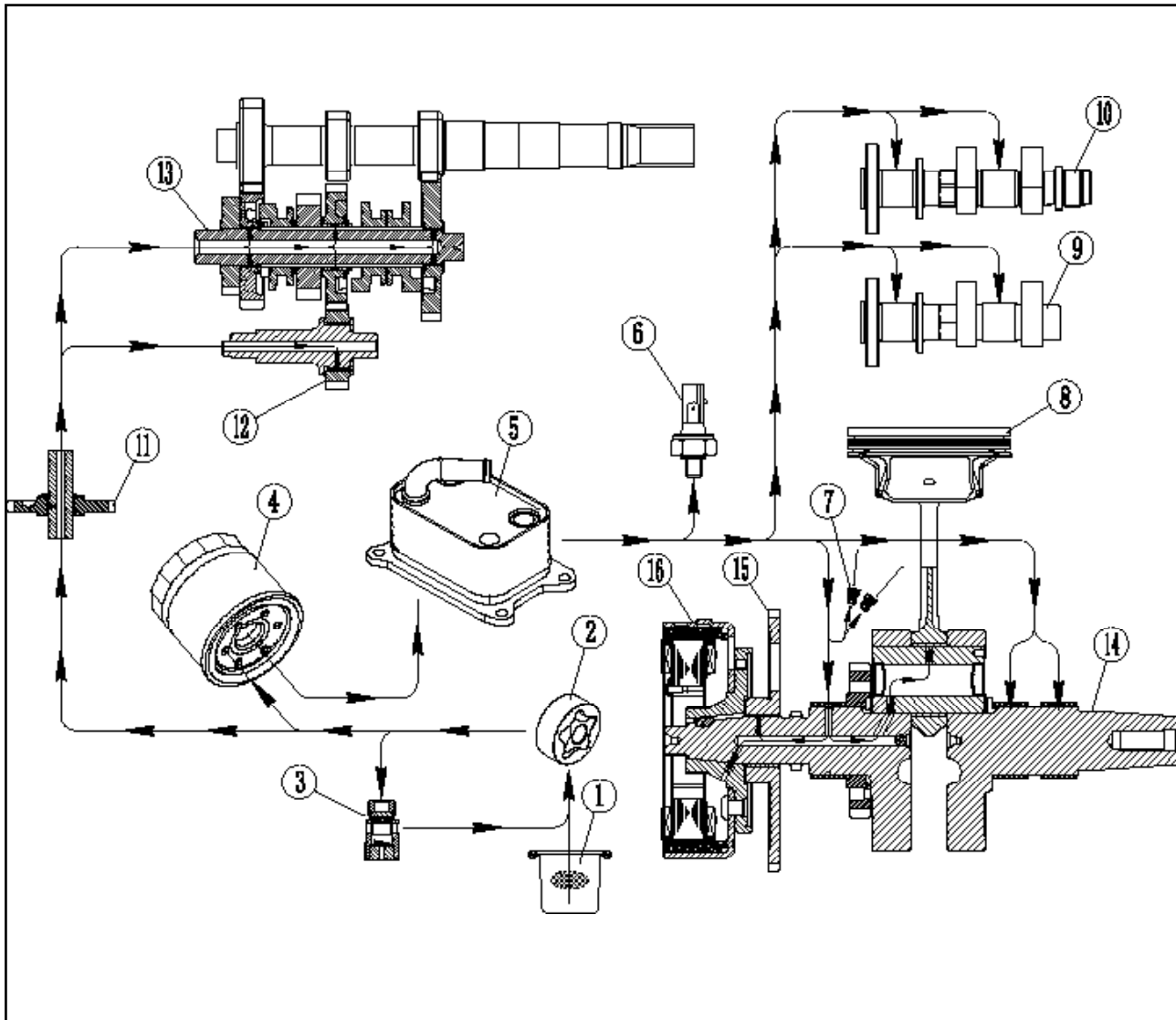

1	Strainer Filter	7	Oil Nozzles	13	Transmission Countershaft Assembly
2	Oil Pump	8	Piston	14	Crankshaft
3	Oil Pressure Valve Unit	9	Intake camshaft	15	Starter One-Way Gear
4	Oil Filter	10	Exhaust camshaft	16	Alternator Stator and Rotor
5	Oil Cooler	11	Oil Pump Idler Gear		
6	Oil Pressure Sensor	12	R Idler Gear		

ENGINE OIL AND OIL FILTER



⚠ WARNING

Vehicle operation with insufficient, deteriorated, or contaminated engine oil will cause accelerated wear and may result in engine or transmission seizure, accident, and injury.

OIL LEVEL INSPECTION

- ◆ Park the vehicle so that it is level, both side-to-side and front-to-rear.
- ◆ If the oil has just been changed, start the engine, and run it for several minutes to fill the oil filter.

⚠ CAUTION

Allow the engine to idle for several minutes so that oil may reach all parts of the engine. Running a "dry" engine may cause severe damage.

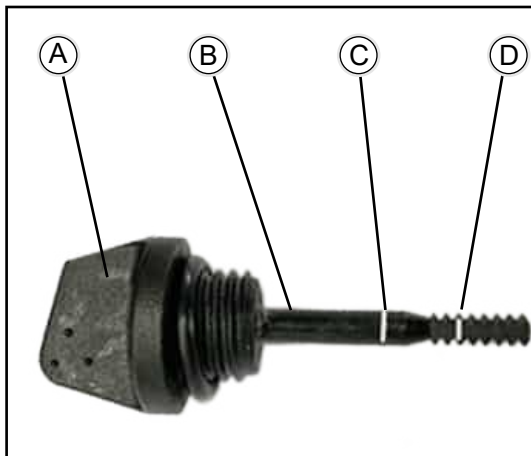

- ◆ Stop the engine and wait several minutes for all the oil to drain back to the sump.
- ◆ Unscrew the oil filler cap **【A】** wipe its dipstick **【B】** dry, and tighten it into the filler opening.
- ◆ Unscrew the oil filler cap and check the oil level. The oil level should be between the upper (H) level line **【C】** and lower (L) level line **【D】**.

If the level is too high, suck the excess oil out the filler hole with a syringe or other suitable device.

If the level is too low, add oil through the filler hole. Use the same type and make of oil that is already in the engine.

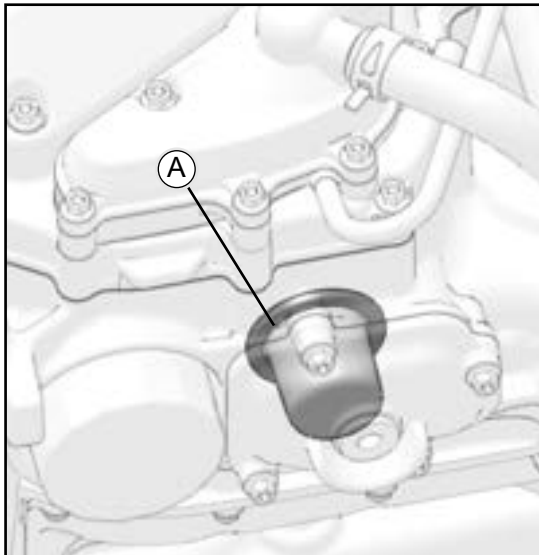

ENGINE OIL CHANGE

- ◆ Refer to the Engine Lubrication System in the Periodic Maintenance chapter.

OIL FILTER CHANGE

- ◆ Refer to the Engine Lubrication System in the Periodic Maintenance chapter to fill the oil filter.

COARSE FILTER REMOVAL

- ◆ Remove the Coarse Filter Cover.
- ◆ The Coarse Filter **【A】** out of the crankcase.

COARSE FILTER CLEANING

- ◆ Clean the Coarse Filter **【A】** thoroughly whenever it is removed for any reason.
- ◆ Clean the Coarse Filter with an appropriate solvent and remove any particles stuck to it.

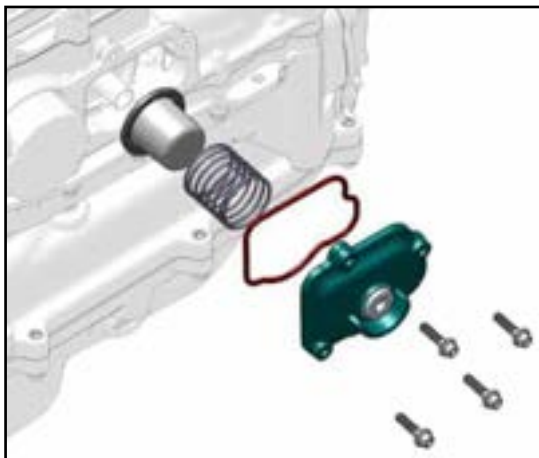

⚠ WARNING

Clean the Coarse Filter in a well-ventilated area, and take care that there is no spark or flame anywhere near the working area. Because of the danger of highly flammable liquids, do not use gasoline or low flash-point solvents.

TIPS

- ◆ While cleaning the Coarse Filter, check for any metal particles that might indicate internal engine damage.
- ◆ Check the Coarse Filter carefully for any damage, holes, broken wires, or gasket pulling off.

If the Coarse Filter is damaged, replace it.



OIL PRESSURE

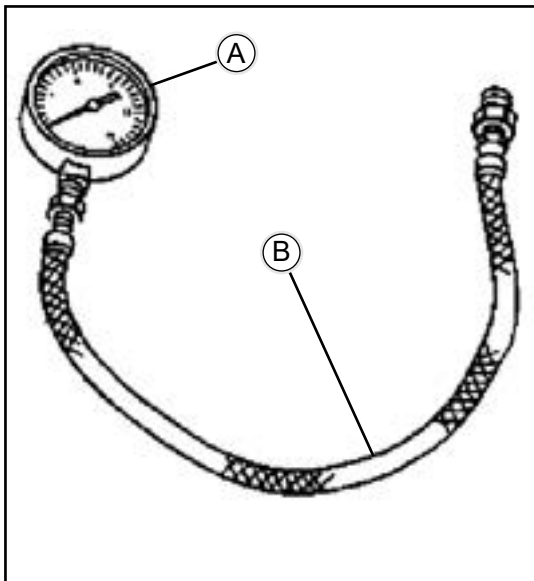
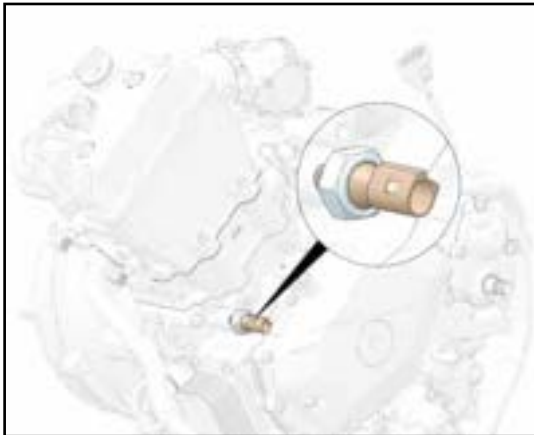

OIL PRESSURE MEASUREMENT

NOTE

Measure the oil pressure after the engine is warmed up.

- ◆ Remove the oil pressure switch, and attach the oil pressure gauge **【A】** and adapter **【B】**.

Tools:

Oil Pressure Gauge, 10 kgf/cm²

Oil Pressure Gauge Adapter

Oil Pressure

Standard: 400 kPa (4.1 kgf/cm², 58psi)@4500r/min (rpm), 110°C (230°F) of oil temp.

If the oil pressure is much lower than the standard, inspect the relief valve, oil pump, and/or crankshaft bearing insert wear.

If the oil pressure is much higher than the standard, inspect the oil filter, oil screen, and other areas of the lubrication system for clogging.

- ◆ Stop the engine.
- ◆ Remove the oil pressure gauge and adapter.

⚠ WARNING

Take care against burns from hot engine oil that will drain through the oil passage when the gauge adapter is removed.

- ◆ Apply silicone sealant to the oil pressure switch, and tighten it.
- ◆ Sealant - Silicone Sealant
- ◆ Torque

Oil Pressure Switch

15 N·m (1.5 kgf·m, 11 ft·lb)

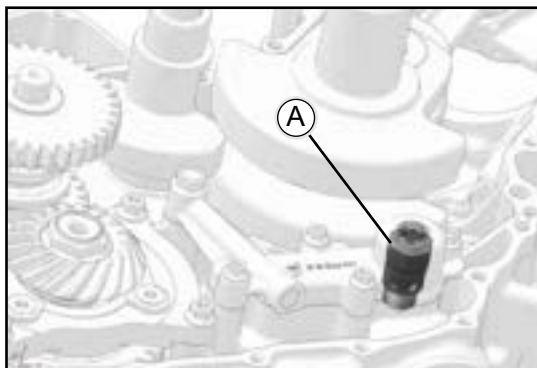

OIL PRESSURE VALVE REMOVAL

- ◆ Split the crankcase (see Crankshaft / Transmission chapter).
- ◆ Remove the oil pressure relief valve Cover.
- ◆ Remove the oil pressure relief valve **【A】** .

OIL PRESSURE VALVE INSTALLATION

- ◆ See crankcase assembly (See Crankshaft / Transmission chapter).
- ◆ Apply a non-permanent locking agent to the threads of oil pressure relief valve, and tighten it.

Torque-

Oil Pressure Relief Valve
15N·m(1.5kgf·m, 11ft·lb)

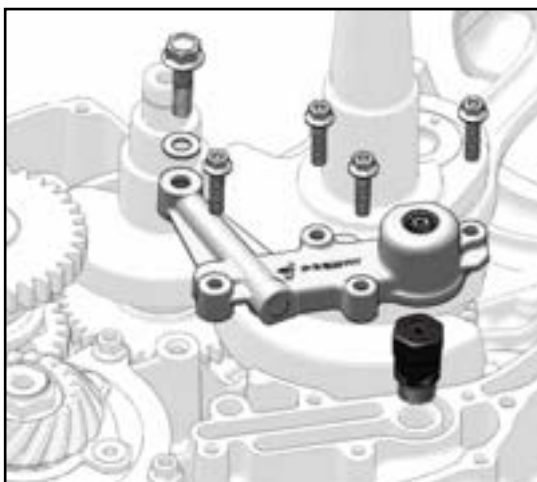

OIL PRESSURE VALVE INSPECTION

- ◆ Remove the relief valve.
- ◆ Push the inner valve to make sure that the valve **【A】** moves smoothly and that it returns to its original position by the force of the spring **【B】** .

NOTE

The Oil Pressure Valve cannot be disassembled and it must be inspected in the assembled state.

If the valve movement is not smooth, wash the relief valve with high flash-point solvent, and use compressed air to remove any foreign particles from it.

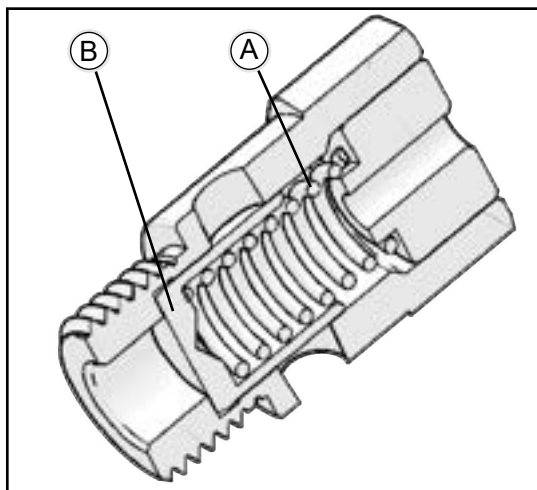

⚠ WARNING

Clean the oil pressure relief valve in a well -ventilated area, and take care that there is no spark or flame anywhere near the working area. Because of the danger of highly flammable liquids, do not use gasoline or low-flash point solvents.

If the valve does not move smoothly even after washing it, replace the relief valve. The oil pressure relief valve is precision made with no allowance for replacement of individual parts.



OIL PUMP



OIL PUMP REMOVAL

◆ Remove:

Alternator Rotor and Starter Clutch Gear(see Electrical System chapter).

◆ Remove:

【A】 E-Ring 9

【B】 Flat Washer 12×20×1

【C】 Driven Gear,Oil Pump

【D】 Needle Roller 4×15.8

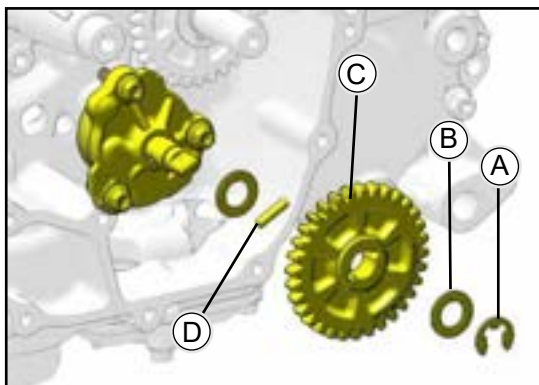

◆ Remove:

【B】 Oil Pump Bolts

【A】 Oil Pump Cover

【E】 Shaft,Oil Pump

【F】 Needle Roller 4×15.8

【C】 Inner Rotor

【D】 Outer Rotor

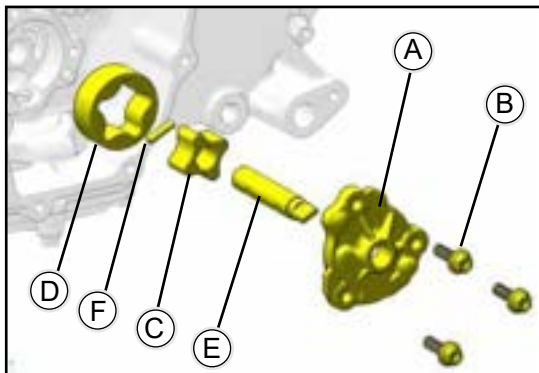

OIL PUMP INSTALLATION

Apply engine oil:

◆ Oil Pump Shaft

◆ Inner and Outer Rotors

Install:

◆ Outer Rotor 【D】

◆ Shaft,Oil Pump 【E】

◆ Needle Roller 4×15.8 【F】

◆ Inner Rotor 【C】

◆ Check to see that the dowel pins 【G】 are in place

◆ Apply engine oil to the oil pump hole 【H】

◆ Oil Pump Cover 【A】

◆ Tighten:

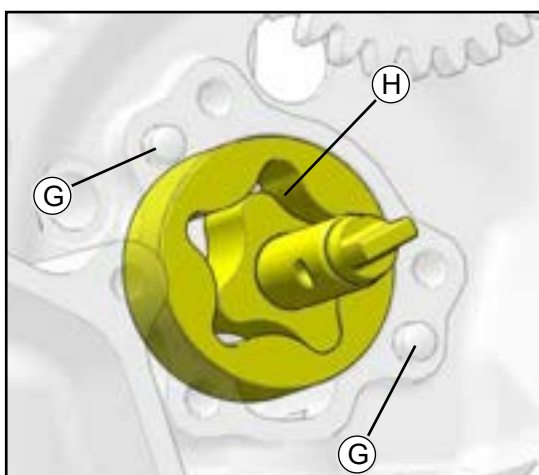

Oil Pump Bolts

10 N·m (1kgf·m, 7ft·lb)

OIL PUMP GEAR

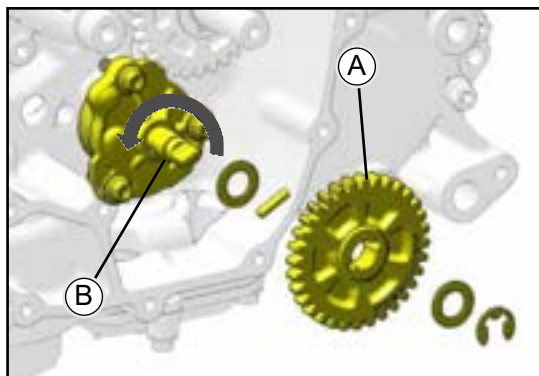

- ◆ Check the flexibility of the Oil Pump Shaft rotation
- ◆ Install the Oil Pump Driven Gear **【A】** with the Oil Pump **【B】** .

OIL PUMP GEAR REMOVAL

- ◆ Remove:
- Oil Pump Idler Gear Shaft **【E】**
- Washer 15×28×1 **【G】**
- Oil Pump Idler Gear **【H】**
- Hexagon Flange Boltm 10×1.25×25 **【A】**
- Flat Washer10×30×3 **【B】**
- Drive Gear **【D】**
- Flat Key **【C】**



OIL PUMP GEAR INSTALLATION

- ◆ Apply engine oil:
- Oil Pump Idler Gear
- Oil Pump Idler Gear Shaft
- ◆ Install:
- Drive Gear **【D】**
- Flat Key **【C】**
- Flat Washer10×30×3 **【B】**
- Hexagon Flange Bolt M10×1.25×25 **【A】**
- ◆ Tighten:

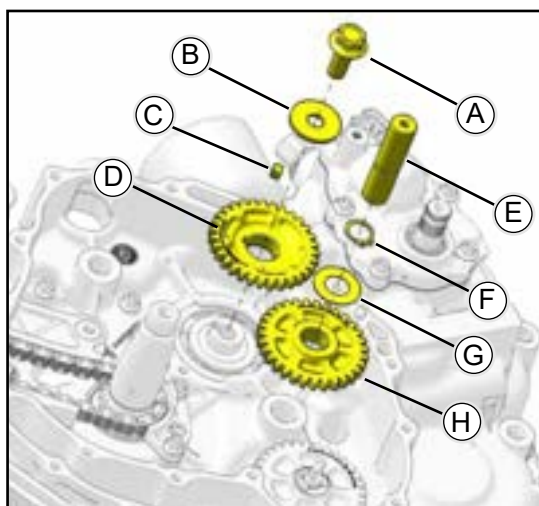

Bolt 【A】

80N·m(8kgf·m, 58ft·lb)

- Oil Pump Idler Gear **【H】**
- Washer 15×28×1 **【G】**
- Oil Pump Idler Gear Shaft **【E】**

OIL COOLER

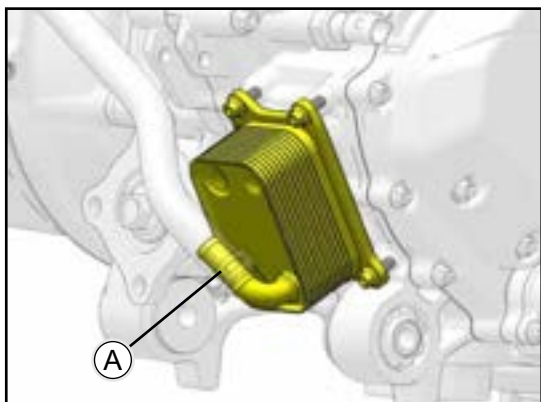

OIL COOLER REMOVAL

- ◆ Remove:
- Drain the engine coolant and oil
- Spring band hose clamps **【A】**
- Screw M6×16 **【B】**
- Cooler **【C】**
- O-Ring 19×2.5 **【D】**

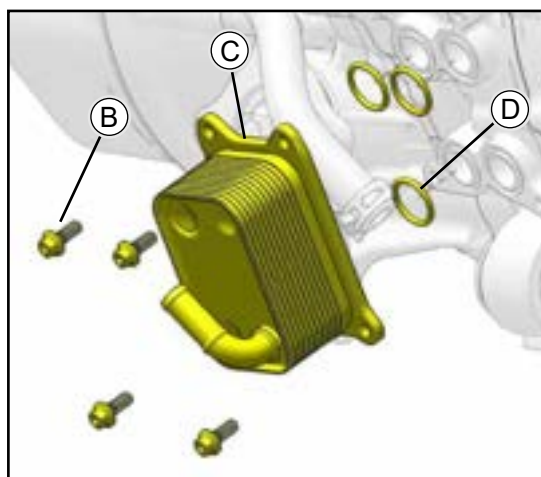

OIL COOLER INSTALLATION

- ◆ Install:
- 1. Replace the O-ring **【D】** with new ones
- 2. Cooler **【C】**
- 3. Screw M6×16 **【B】**

Torque

Oil Pump Bolts 【B】
10 N·m (1kgf·m, 7ft·lb)

- 4. Spring band hose clamps **【A】**
- 5. Fill the engine coolant and oil

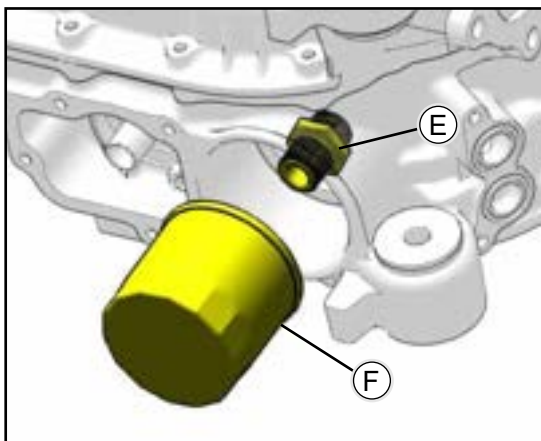

OIL FILTER REMOVAL

- ◆ Remove:
- Oil Filter **【F】**

OIL FILTER INSTALLATION

- ◆ Install:
- Oil Filter **【F】**

- ◆ Tighten:

Torque

Oil Filter Adapter 【E】
40 N·m (4kgf·m, 28 ft·lb)

Oil Filter 【F】
18 N·m (1.8 kgf·m, 13 ft·lb)

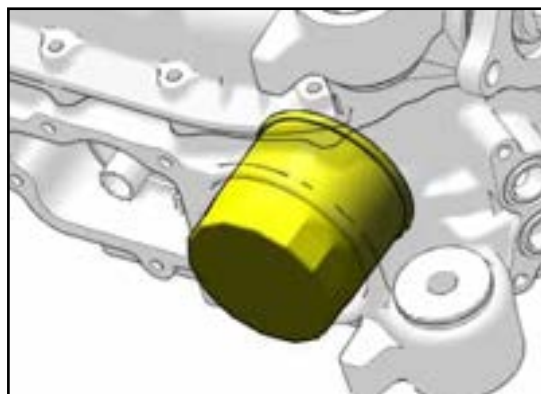

CRANKSHAFT / TRANSMISSION

EXPLODED VIEW	3-2-2
TECHNICAL PARAMETER	3-2-8
SPECIAL TOOLS AND SEALANTS	3-2-9
CRANKCASE	3-2-10
CRANKCASE DISASSEMBLY	3-2-10
CRANKCASE ASSEMBLY	3-2-13
CRANKSHAFT	3-2-24
CONNECTING ROD BIG END SIDE CLEARANCE	3-2-24
CRANKSHAFT RUNOUT	3-2-24
CRANKSHAFT MAIN BEARING/JOURNAL WEAR	3-2-24
TRANSMISSION	3-2-25
TRANSMISSION REMOVAL.....	3-2-25
TRANSMISSION INSTALLATION	3-2-27
SHIFT FORK BENDING.....	3-2-28
SHIFT FORK/GEAR AND SHIFTER GROOVE WEAR.....	3-2-28
TRANSMISSION AND SHIFT MECHANISM INSPECTION	3-2-29
BALL BEARING, NEEDLE BEARING, AND OIL SEAL	3-2-31
BALL AND NEEDLE BEARING REPLACEMENT	3-2-31
BALL AND NEEDLE BEARING WEAR.....	3-2-31
OIL SEAL INSPECTION.....	3-2-32

EXPLODED VIEW

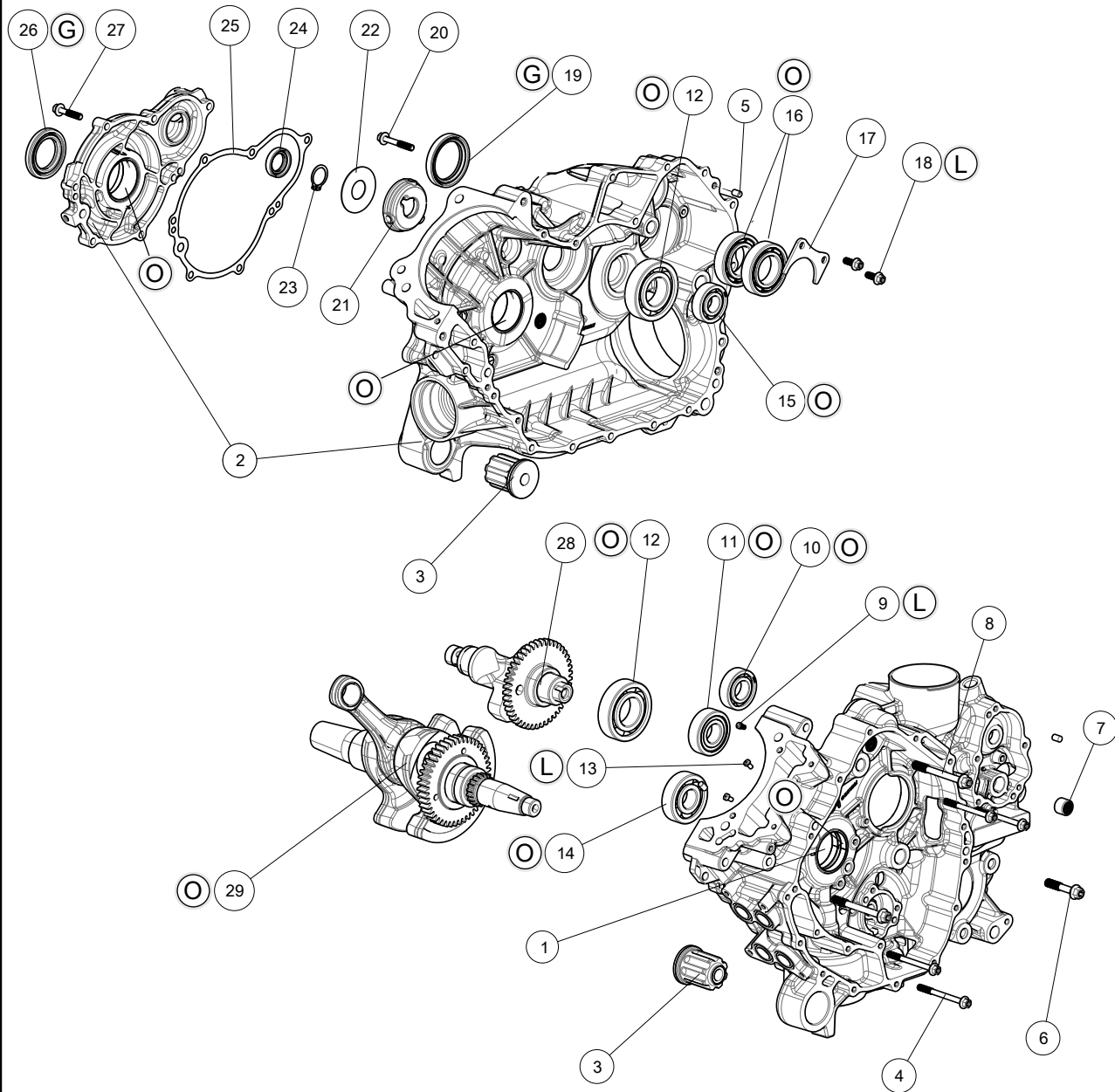
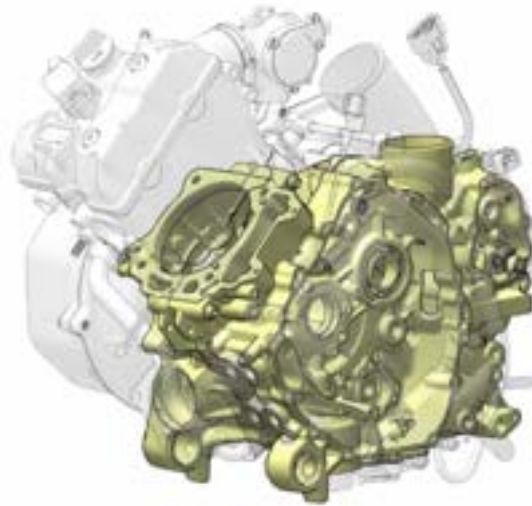

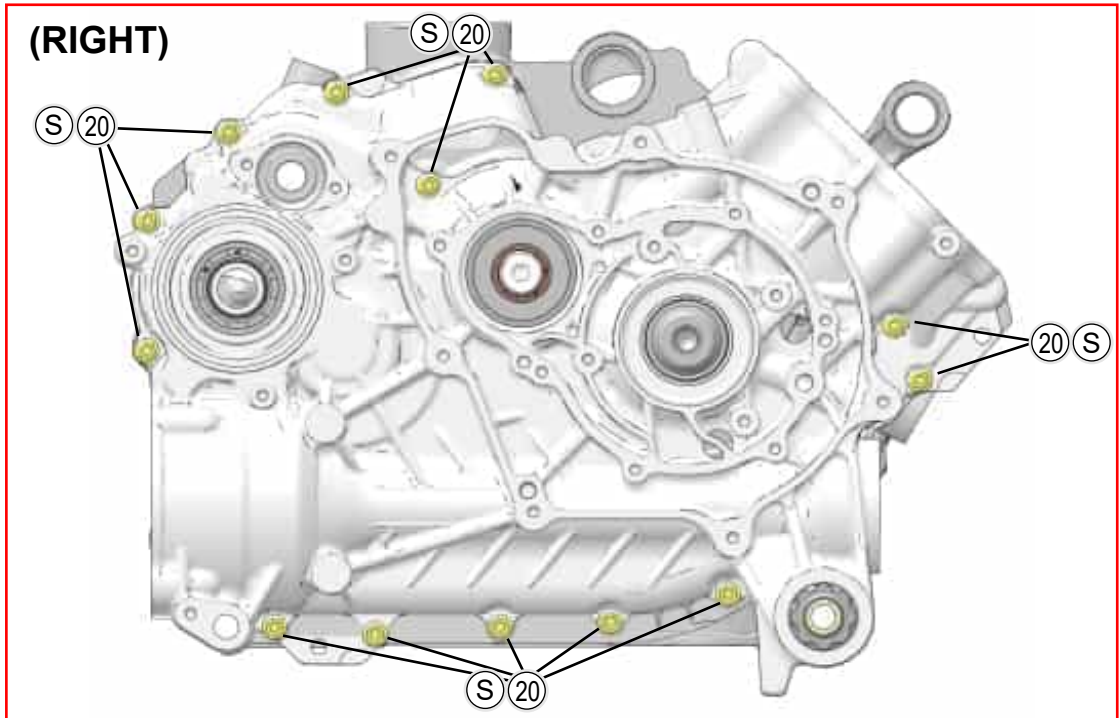
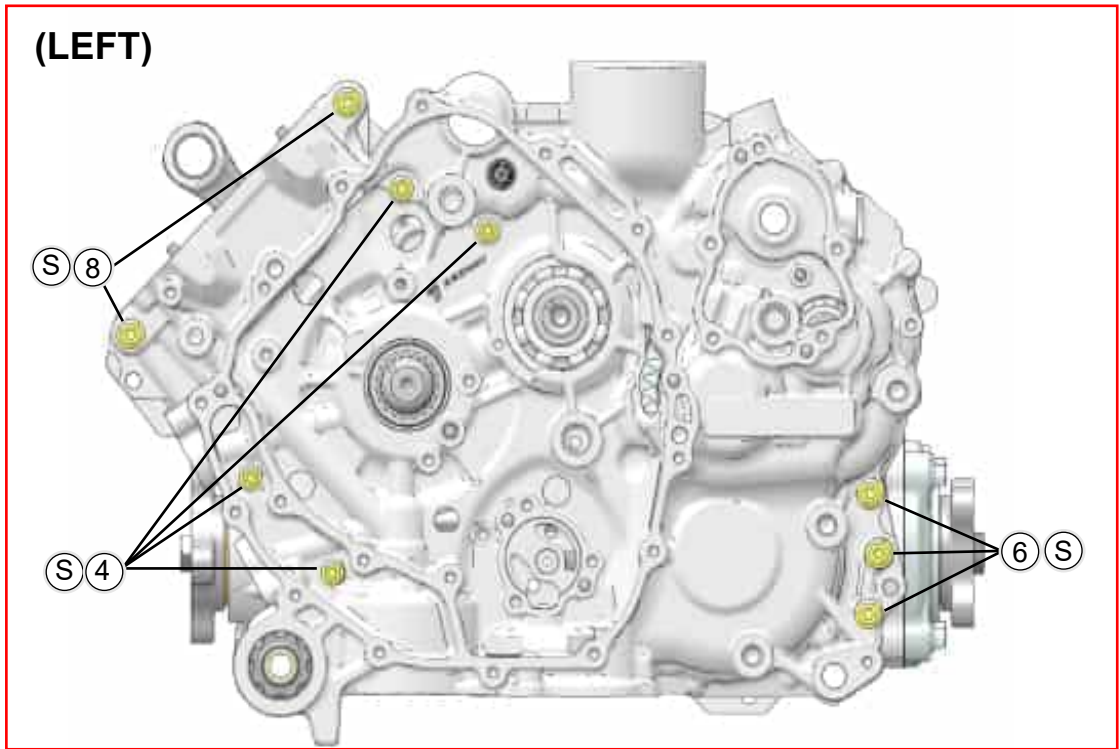

NO.	NAME	TORQUE			REMARKS
		N·M	KGF·M	FT·LB	
1	Left Crankcase Assembly				SS,O
2	Right Crankcase & Right Cover Combination				SS,O
3	Isolator				
4	Bolt M6×65	9.8	1.0	87 in·lb	S
5	Dowel Pin 6×10				
6	Bolt M8×40	26	2.7	20	S
7	Needle Roller Bearing HK121612				
8	Bolt M8×70	26	2.7	20	S
9	Flow Orifice Φ1	2.5	0.25	21 in·lb	L
10	Bearing 6004				O
11	Bearing 6204Z				O
12	Bearing 6206				O
13	Piston Injection Hole Plug	4	0.4	35 in·lb	L
14	Bearing 6304				O
15	Bearing 6203				O
16	Bearing 6006				O
17	Plate,Bearing Retainer				
18	Bolt M6×16	9.8	1.0	87 in·lb	L
19	Oil Seal 42×55×8				G
20	Bolt M6×40	9.8	1.0	87 in·lb	S
21	Centrifugal Oil-Air Separator				
22	Respirator Cover				
23	Circlip 20				
24	Oil Seal 20×30×7				G
25	Right Crankcase Cover Gasket				
26	Oil Seal 35×52×7				G
27	Bolt M6×30	9.8	1.0	87 in·lb	S
28	Balance Shaft Assembly				
29	Crankshaft Connecting Rod Parts				O

G: Apply grease for oil seal and O-ring.

L: Apply a non-permanent locking agent.

O: Apply engine oil.

SS: Apply silicone sealant.

R: Replacement Parts.

S: Follow the specific tightening sequence.

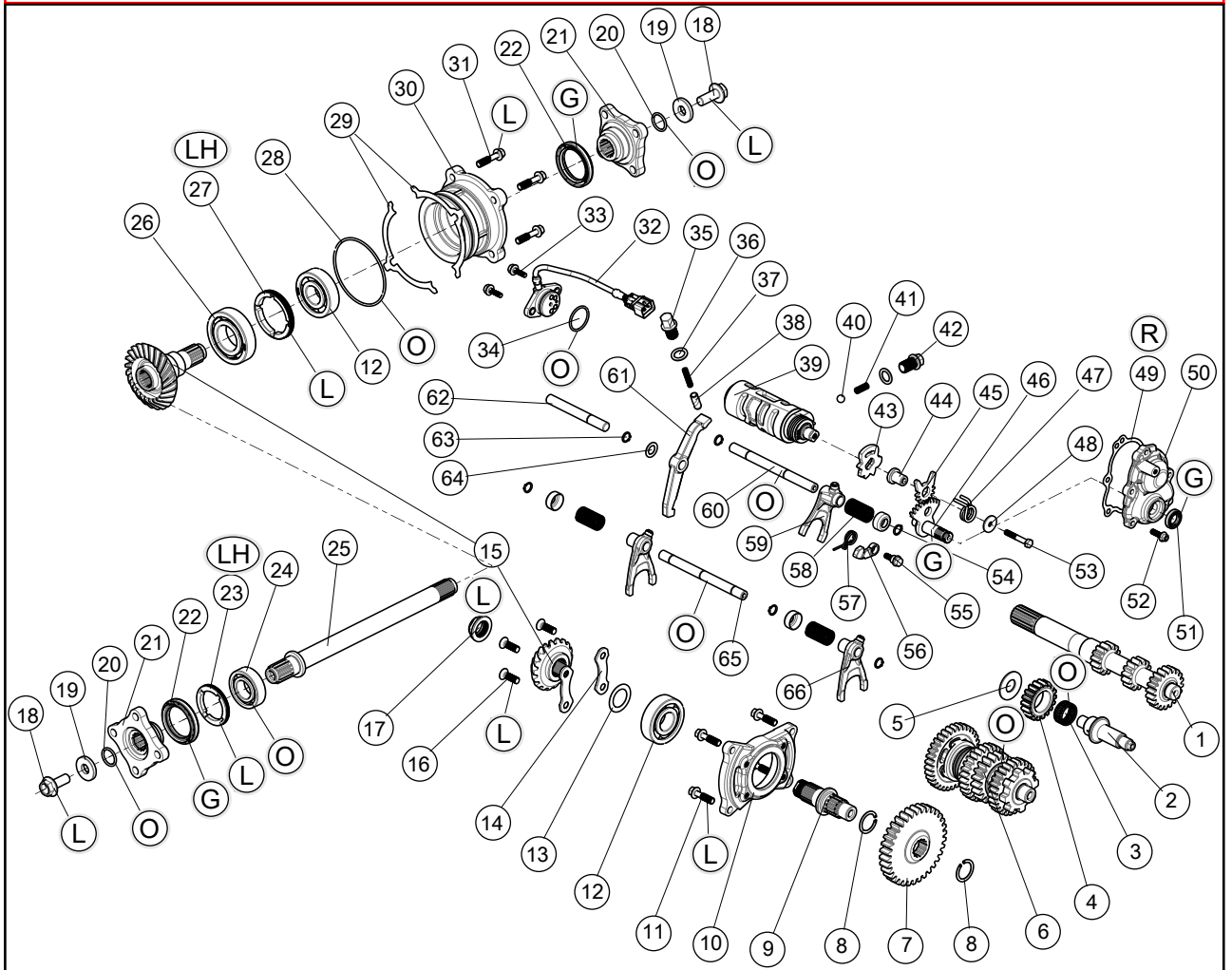
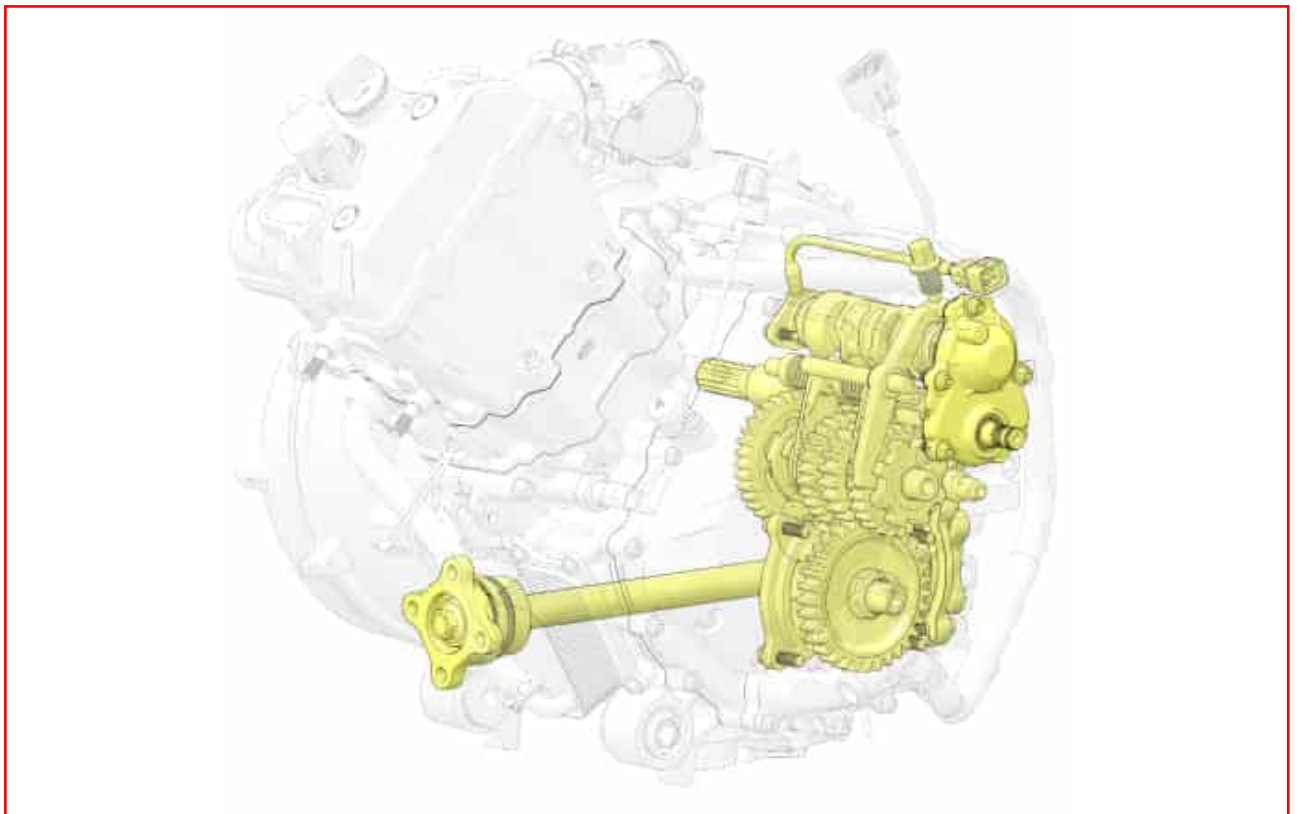

CRANKSHAFT / TRANSMISSION

SEGWAY AT5

NO.	NAME	TORQUE			REMARKS
		N·M	KGF·M	FT·LB	
1	Transmission Main Shaft				
2	Idle Shaft				
3	Needle Roller Bearing K252913				O
4	R Idle Gear				
5	Spacer 17×38×2				
6	Transmission Countershaft Assembly				O
7	Reduction Driven Gear				
8	Circlip 25×1.2				
9	Drive Bevel Gear Shaft				
10	Drive Bevel Gear Housing				
11	Bolt M8×30	26	2.7	20	L
12	Bearing 6305				
13	Drive Bevel Gear Shims				
14	Bearing Husing Plate				
15	Drive&Driven Bevel Gear Kit				
16	Screw M8×25	26	2.7	20	L
17	Nut M22×1	180	18.4	133	L
18	Bolt M12×1.25×30	120	12	89	L
19	Spacer 12.5×32×5				
20	O-Ring 20×2.65				O
21	Transmission Shaft Flange				
22	Oil Seal 44×60×7				G
23	Nut M55×1.5×6-LH	120	12	89	L,Lh
24	Bearing 6205				
25	Transmission Shaft				
26	Bearing 6207				O
27	Nut M65×1.5×8-LH	137	14	106	L,Lh
28	O-Ring 88×2.8				O
29	Driven Bevel Gear Shims				
30	Driven Bevel Gear Housing				
31	Bolt M8×35	26	2.7	20	L
32	Gear Sensor				
33	Bolt M6×20	9.8	1.0	87in·lb	
34	O-Ring 29.6×2.4				O
35	Parking Brake Spring Plug	25	2.5	18	
36	Gasket 14×21×1.5				
37	Parking Brake Arm Spring				
38	Parking Brake Pin				
39	Shift Drum				
40	Ball 3/8				
41	Neutral Position Spring				
42	Neutral Position Spring Plug	25	2.5	18	
43	Positioning Star				
44	Sector Gear Spacer				
45	Sector Gear				
46	Shift Shaft				
47	Sector Gear Torsion Spring				
48	Spacer 6.2×22×2				

CRANKSHAFT / TRANSMISSION

SEGWAY AT5

NO.	NAME	TORQUE			REMARKS
		N·M	KGF·M	FT·LB	
49	Shiftshaft Cover Gasket				R
50	Shiftshaft Cover				
51	Oil Seal 15×25×5				G
52	Bolt M6×20	9.8	1.0	87 in·lb	
53	Bolt M6×40	14	1.4	10	L
54	Shift Fork Spring Seat				
55	Shoulder Bolt	14	1.4	10	L
56	Detent Pawl				
57	Detent Pawl Torsion Spring				
58	Shift Fork				
59	Shift Fork L				
60	Shift Rail L				O
61	Parking Brake Arm				
62	Parking Brake Arm Shaft				
63	Circlip 12				R
64	Spacer 12×20×1				
65	Shift Rail H/R				O
66	Shift Fork H/R				

G: Apply grease for oil seal and O-ring.

L: Apply a non-permanent locking agent.

O: Apply engine oil.

R: Replacement Parts.

TECHNICAL PARAMETER

Item	Standard	Service Limit
Transmission:		
Shift fork ear thickness:	5.8 ~ 5.9 mm	5.7 mm
Shifter groove width:	6.0 ~ 6.1 mm	6.2 mm

SPECIAL TOOLS AND SEALANTS

Outside Circlip Pliers

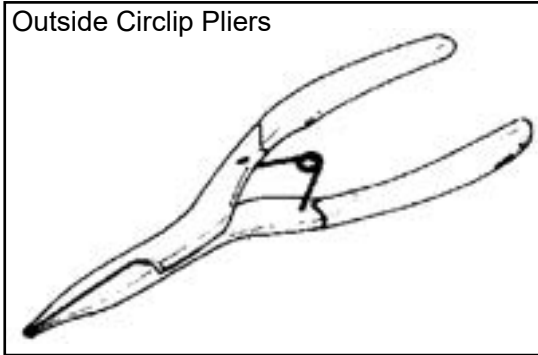

Bearing Driver Set



Sealant: 5699

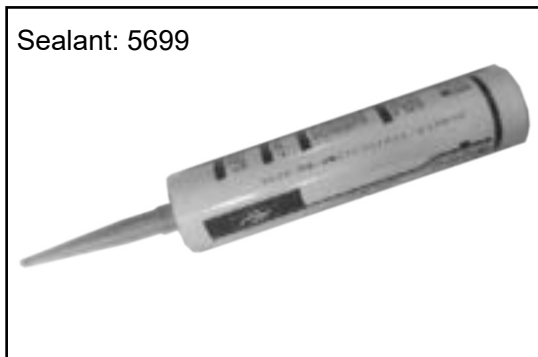

CRANKCASE

CRANKCASE DISASSEMBLY

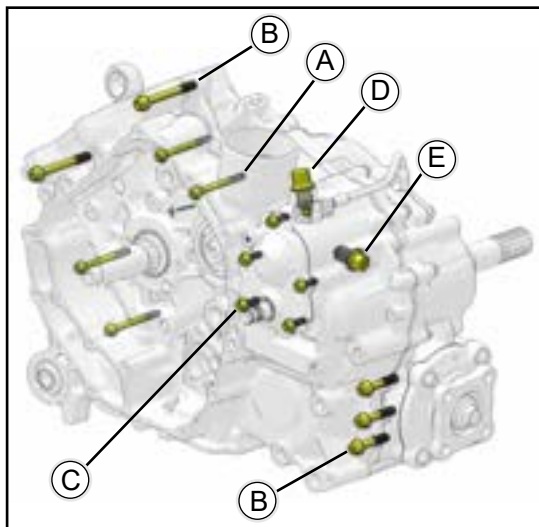

◆ Remove:

1. Engine (see Engine Removal/Installation chapter)
2. Starter Motor (see Electrical System chapter)
3. Oil Filter (see Engine Lubrication System chapter)
4. Cylinder Blocks and Pistons (see Engine Top End chapter)
5. Camshaft and Chain (see Engine Top End chapter)
6. Left Crankcase Bolts (M6) 【A】
7. Left Crankcase Bolts (M8) 【B】
8. Shiftshaft Cover Bolts (M6) 【C】
9. Parking Brake Spring Plug 【D】 , Gasket, Spring, and Parking
10. Brake Pin.
11. Shift Spring Plug 【E】 ,Gasket, Spring, and Steel Ball.

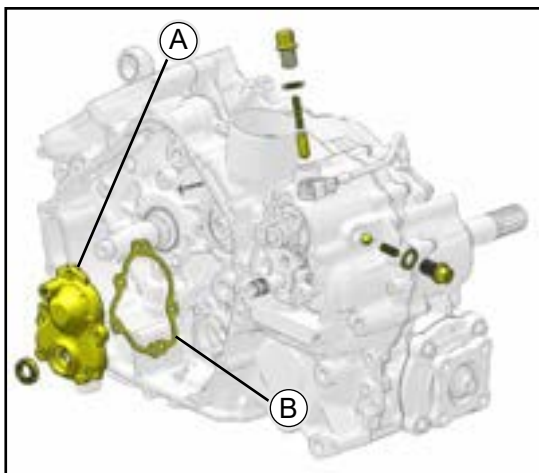

◆ Remove:

- Shiftshaft Cover 【A】
- Gasket, Shiftshaft Cover 【B】



◆ Remove:

1. Shiftshaft 【A】
2. Hexagon Bolt M6×40 【B】 , Spacer , Spring , Shift Driven Gear 【C】 , Bushing , Positioning Star 【D】
3. Shoulder Blots 【E】 , Detent Pawl 【F】 , Spring 【G】 .

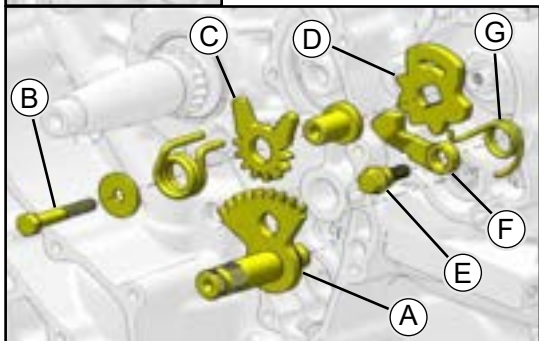

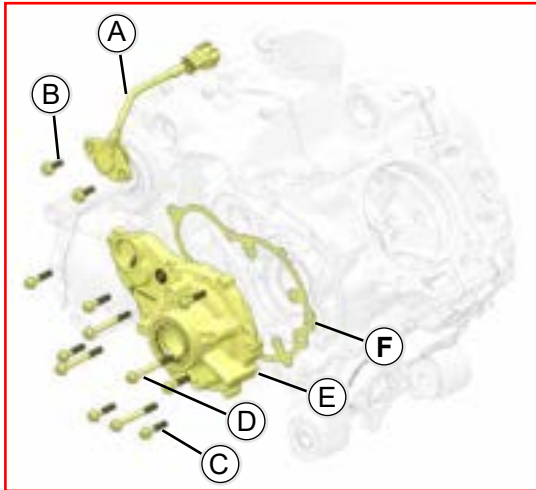

◆ Disassembly:

- Bolt (M6×20) 【B】 .
- Gear sensor 【A】
- Bolt (M6×30) 【C】 .
- Bolt (M6×60) 【D】
- Right crankcase cover 【E】
- Right crankcase cover gasket 【F】 .

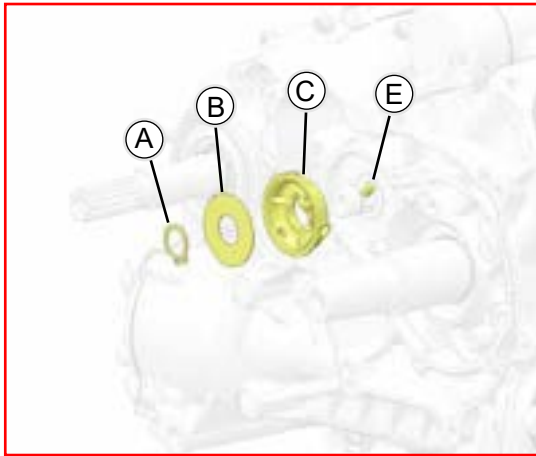

◆ Disassembly:

1. Retaining ring 【A】
2. Respirator cover 【B】
3. Respirator cover 【C】
4. Cylindrical pin 6×10 【E】

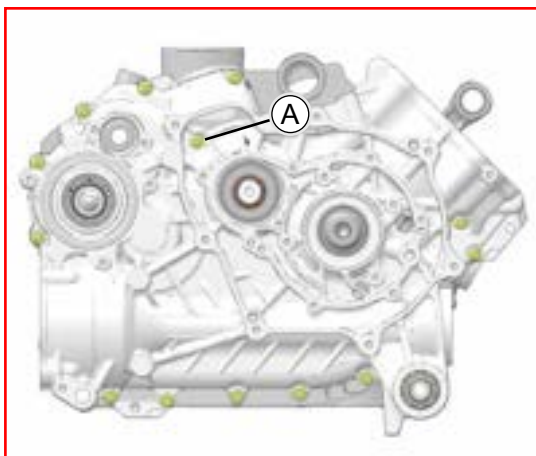

◆ Disassembly:

- Left crankcase bolt M6(13) 【A】

◆ Remove:

1. Wrap the teeth on the sprockets **【B】** by taping for protecting the bushing in the crankcase.

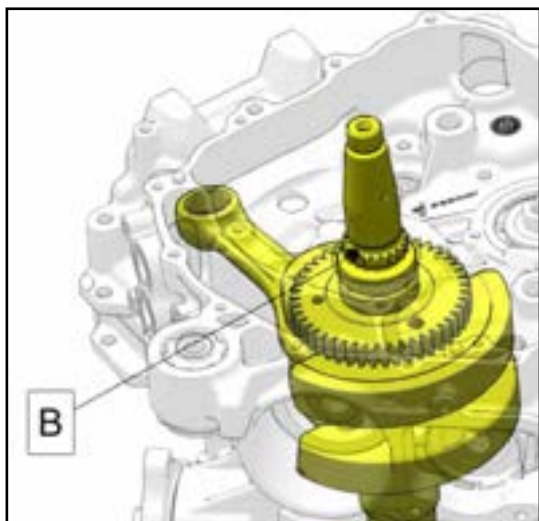

2. Using the pry points **【A】** , split the crankcase halves.
3. Lift off the right crankcase half.

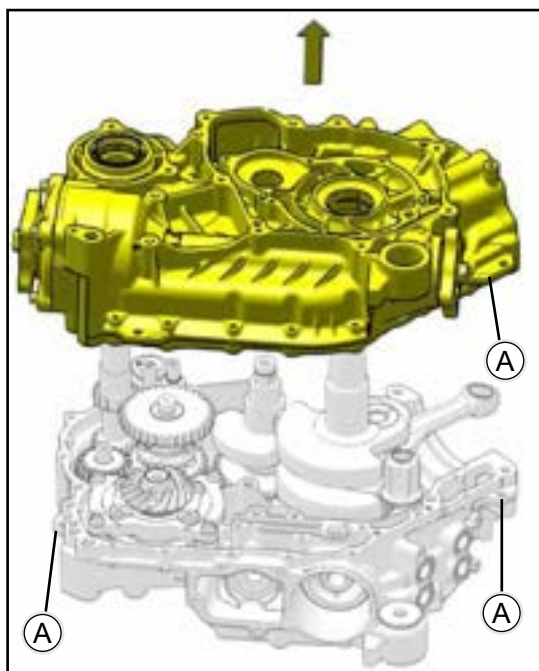

CRANKCASE ASSEMBLY

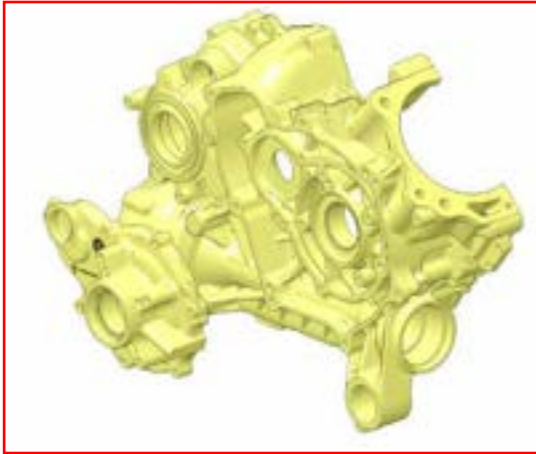
**NOTE**

- ◆ Be certain that all parts are cleaned thoroughly before assembly.
- ◆ Blow through all oil passages with compressed air to clear any blockage in the crankcase halves and crankshaft.

⚠ WARNING

Clean the engine parts in a well-ventilated area, and take care that there are no sparks or flame anywhere near the working area; this includes any appliance with a pilot light. Do not use gasoline or low flash-point solvents to clean parts. A fire or explosion could result.

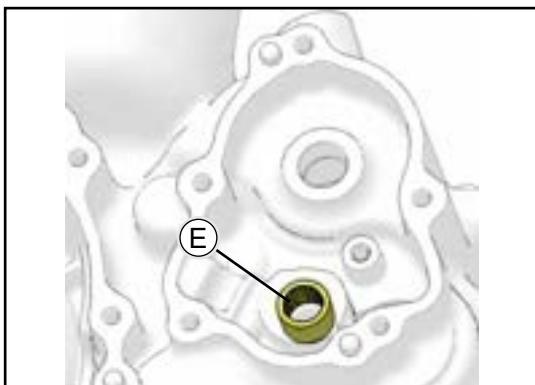
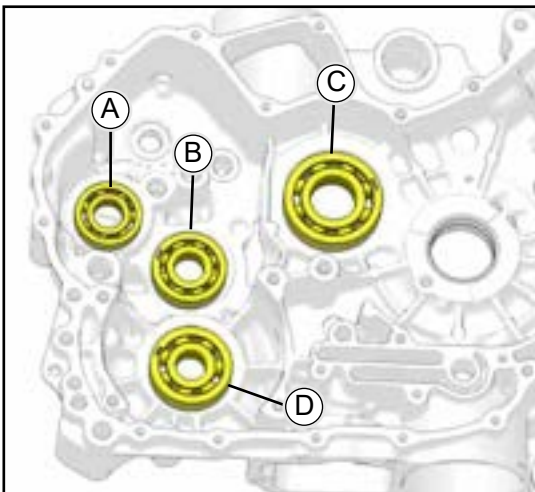

- ◆ Apply a small amount of engine oil to the transmission gears, bearings and shift fork.
- ◆ Be sure the mating surfaces of the crankcase halves are clean and dry.
- ◆ Press and insert the new ball bearings until they are bottomed.

Special Tool - Bearing Driver Set:

【A】 Ball Bearing : 6004

【B】 Ball Bearing : 6204Z

【C】 Ball Bearing : 6206

【D】 Ball Bearing : 6304

- ◆ Press and insert the new needle bearings so that the bearing surfaces are flush with the end of the hole.

【E】 **Needle Bearing : HK121612**

- ◆ Apply engine oil to the bearings.

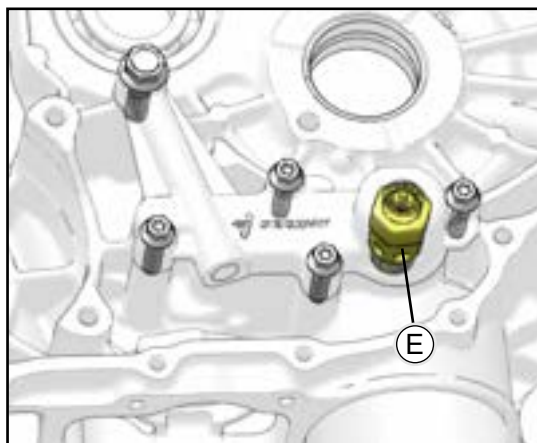

- ◆ Install:
Oil Pressure Relief Valve **【E】** (see Engine Lubrication System chapter)

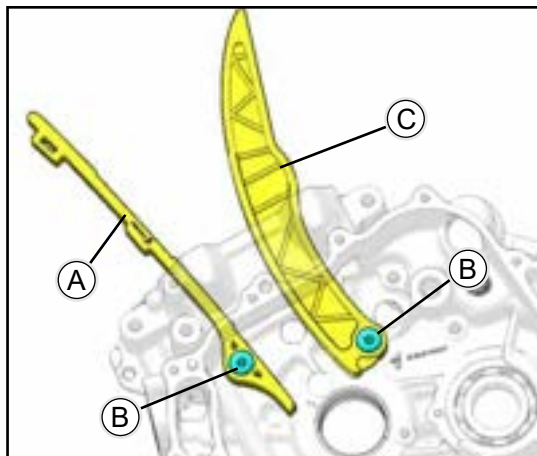

- ◆ Install:
Chain Guide **【A】**
Chain Tensioner **【C】**
- ◆ Tighten:

Torque

Chain Guide Bolts 【B】
12 N·m (1.2 kgf·m, 8.7 ft·lb)

Apply a non-permanent locking agent to the Bolts **【B】** .

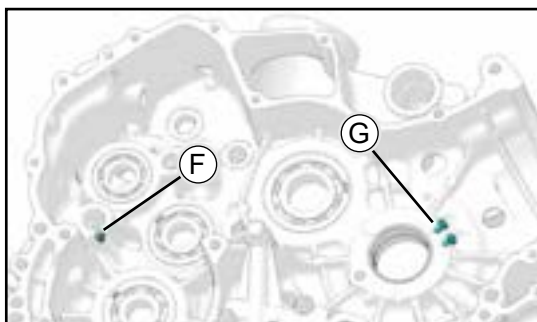

- ◆ Install:
Piston Injection Hole Plug **【G】**
Flow Orifice $\phi 1$ **【F】**

- ◆ Tighten:

Torque

Piston Injection Hole Plug 【G】
4 N·m

Flow Orifice $\phi 1$ 【F】
2.2 N·m

- ◆ Apply a non-permanent locking agent to the **【F】** and **【G】** .

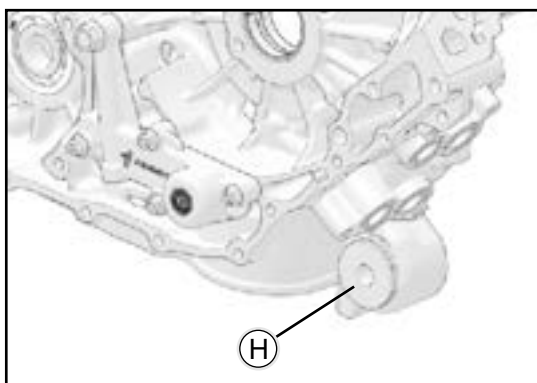

- ◆ Install:
Press and insert Cushion Bushing **【H】** until they are bottomed.

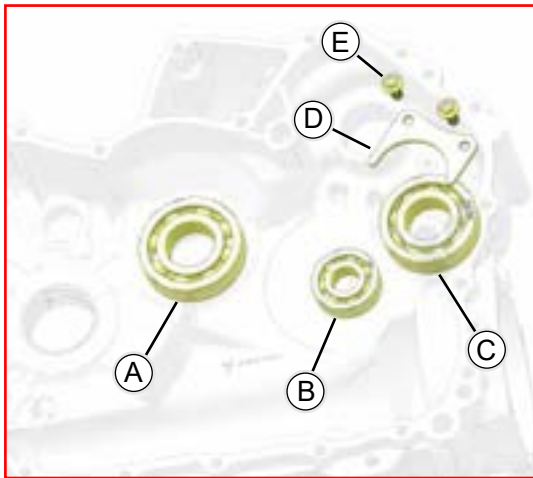

- ◆ Press in the new deep groove ball bearings until they bottom out.

Special Tools - Bearing Mounting Kit:

- 【A】 Deep groove ball bearing: 6206
- 【B】 Deep groove ball bearing: 6203
- 【C】 Deep groove ball bearing: 6228

- ◆ Apply engine oil to the bearings.
- ◆ Spindle bearing baffle 【D】 .
- ◆ Apply thread fastener 【E】 to the baffle mounting bolts.

Tightening torque:

fender mounting bolts
9.8 N·m (1 kgf·m, 87 in·lb)

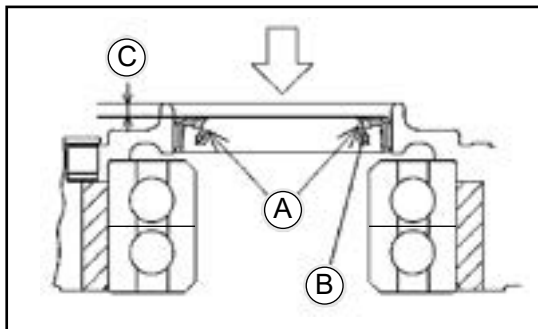

- ◆ Apply grease to the lip 【A】 of the oil seal 42×55×8 【B】 , and press the oil seal inward 0.5 mm 【C】 from the end of the boss.

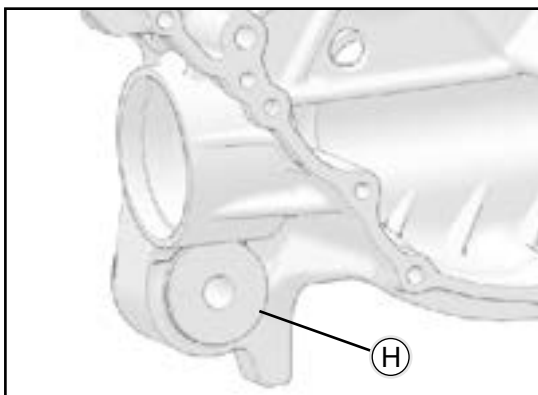
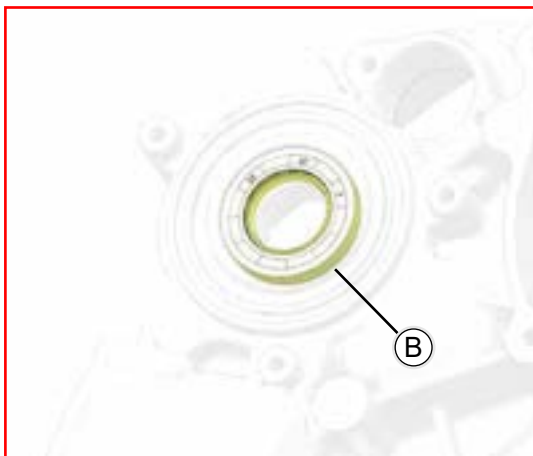

- ◆ Press in the buffer sleeve assembly 【H】 .

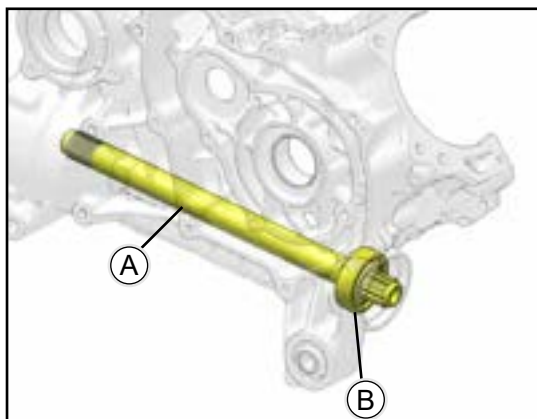

- ◆ Install:
Transmission Shaft **【A】** and new Bearing 6205 **【B】** .
- ◆ Press and insert the bearings until they are bottomed.

Special Tool - Bearing Driver Set:

【B】 Ball Bearing : 6205

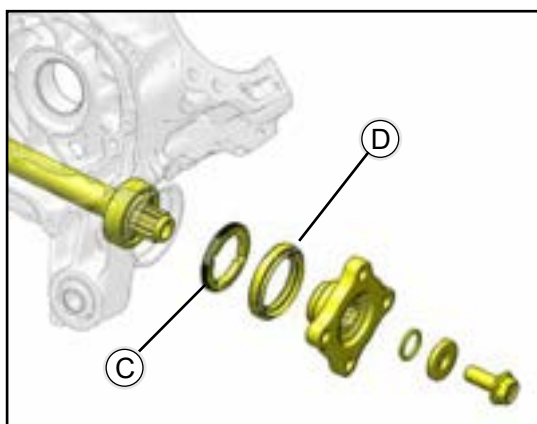

- ◆ Install:
【C】 Nut M55×1.5×6-LH
- ◆ Tighten:

Torque

Nut 【C】
120 N·m (12 kgf·m, 89 ft·lb)

- ◆ Apply a non-permanent locking agent to the Nut **【C】**

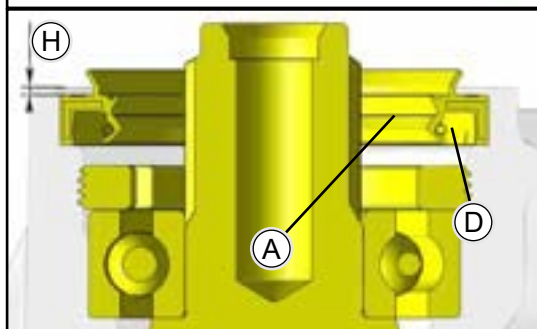

- ◆ Install:
Grease the lip **【A】** of the oil seal 44×60×7 **【D】** and press the seal 1.0 mm **【H】** inwards from the end of the boss.

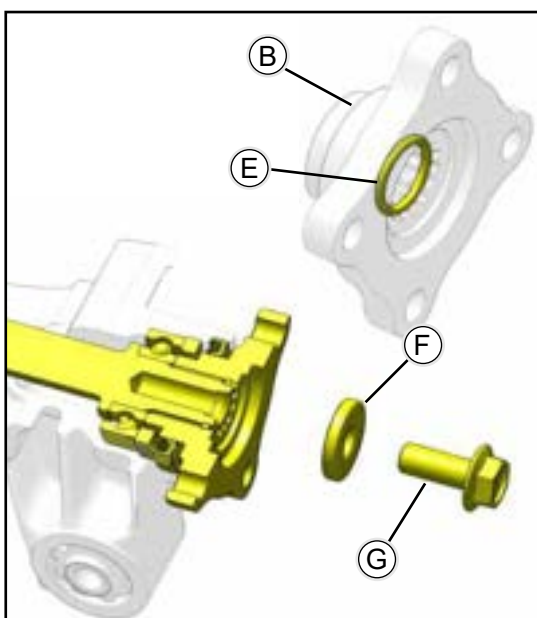

- ◆ Install:
insert the O-Ring 20×2.65 **【E】** to the Transmission Shaft Flange **【B】** .

- ◆ Apply engine oil to the O-Ring **【E】**

Washer 12.5×32×5 **【F】**

Bolt M12×1.25×30 **【G】**

- ◆ Tighten:

Torque

Bolt M12 【G】
120 N·m (12 kgf·m, 89 ft·lb)

- ◆ Apply a non-permanent locking agent to the Bolt **【G】** .

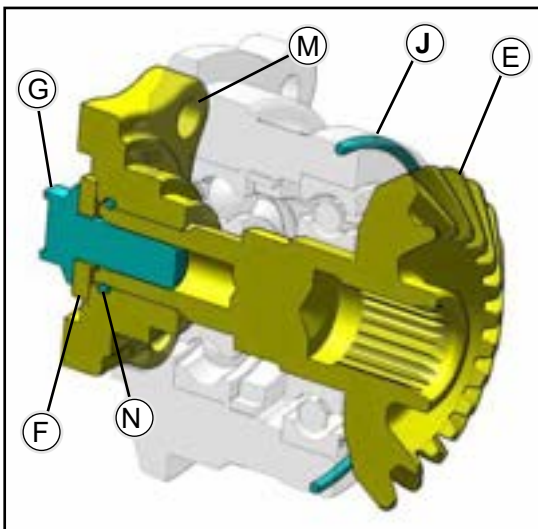
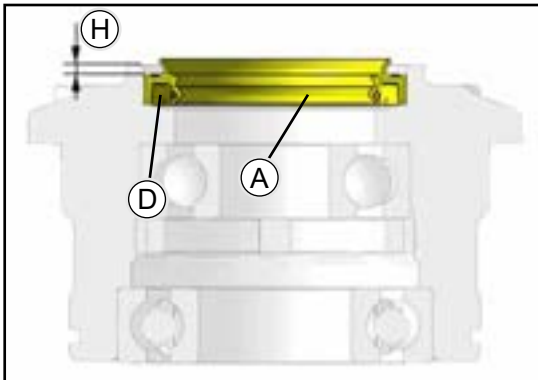
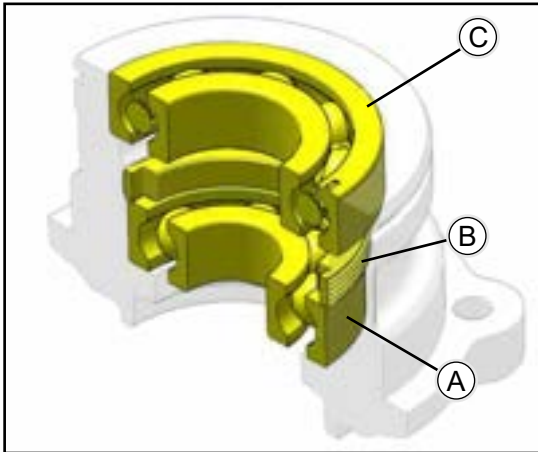
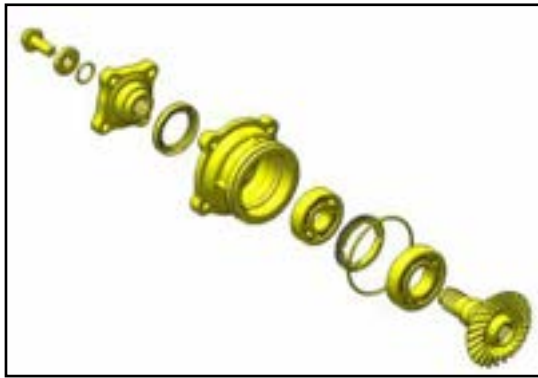

- ◆ Press and insert the bearings until they are bottomed.

Special Tool - Bearing Driver Set

【A】 Ball Bearing : 6305

【C】 Ball Bearing : 6207

- ◆ Install:

Nut M65×1.5×8-LH 【B】 (Left-hand Threads)

- ◆ Tighten:

Torque

Nut 【B】
137 N·m (14 kgf·m, 106 ft·lb)

- ◆ Apply a non-permanent locking agent to the Nut 【B】

- ◆ Install:

Grease the lip 【A】 of the oil seal 44×60×7 【D】 and press the oil seal 2.2 mm 【H】 inwards from the end of the boss.

- ◆ Install:

insert the O-Ring 20×2.65 【N】 to the Transmission Shaft Flange 【M】 .

- ◆ Apply engine oil to the O-Ring 【N】

- ◆ Install:

Driven Bevel Gear 【E】

Washer 12.5×32×5 【F】

Bolt M12×1.25×30 【G】

- ◆ Tighten:

Torque

Bolt M12 【G】
120 N·m (12 kgf·m, 89 ft·lb)

- ◆ Apply a non-permanent locking agent to the Bolt 【G】 .

- ◆ Install:

【J】 O-Ring 88×2.8

- ◆ Apply engine oil to the O-Ring 【J】

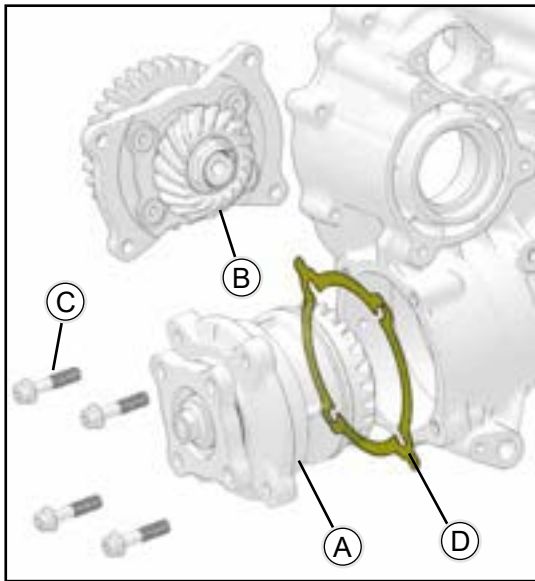

⚠ CAUTION

The Driving Bevel Gear **【B】** and Driven Bevel Gear **【A】** are machined at the factory in the assembled state, so the Driving Bevel Gear and Driven Bevel Gear must be replaced as a set.

◆ Install:

1. Driven Bevel Gear Assembly **【A】**
2. Shim, Driven Bevel Gear **【D】**
3. Bolts M8×35 **【C】**

◆ Tighten:

Torque

Bolts 【C】
26 N·m (2.7 kgf·m, 20 ft·lb)

- ◆ Apply a non-permanent locking agent to the Bolts **【C】**

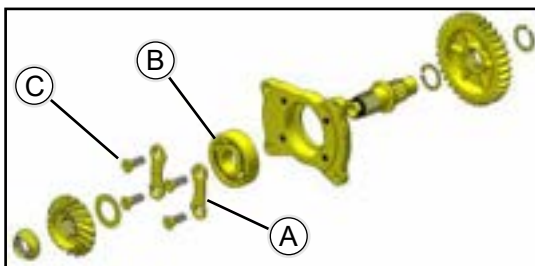

TIPS

Driven bevel gear backlash

Standard: 0.15 ~ 0.25 mm

- ◆ Press and insert the bearings until they are bottomed.

Special Tool - Bearing Driver Set

【B】 Ball Bearing : 6305

◆ Install:

Bearing Frame Plate **【A】**

Screw M8×25 **【C】**

◆ Tighten:

Torque

Screw M8×25 【C】
26 N·m (2.7 kgf·m, 20 ft·lb)

- ◆ Apply a non-permanent locking agent to the Screw **【C】**

◆ Install:

1. Drive Bevel Gear Shaft, Reduction Driven Gear, Circlip Combination **【D】**
2. Drive Bevel Gear Shim **【E】**
3. Drive Bevel Gear **【F】**
4. Nut M22×1 **【G】**

◆ Tighten:

Torque

Nut M22×1 【G】
180 N·m (18.4 kgf·m, 133 ft·lb)

- ◆ Apply a non-permanent locking agent to the Nut **【G】**

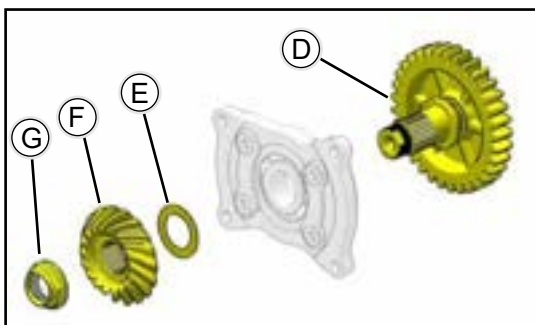

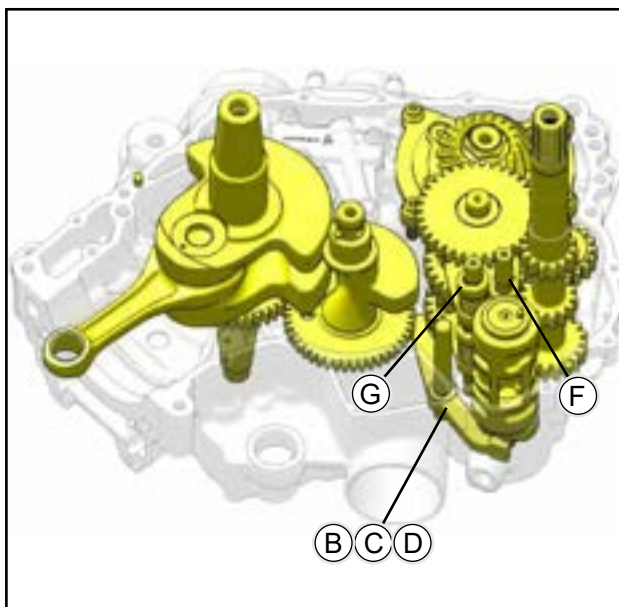
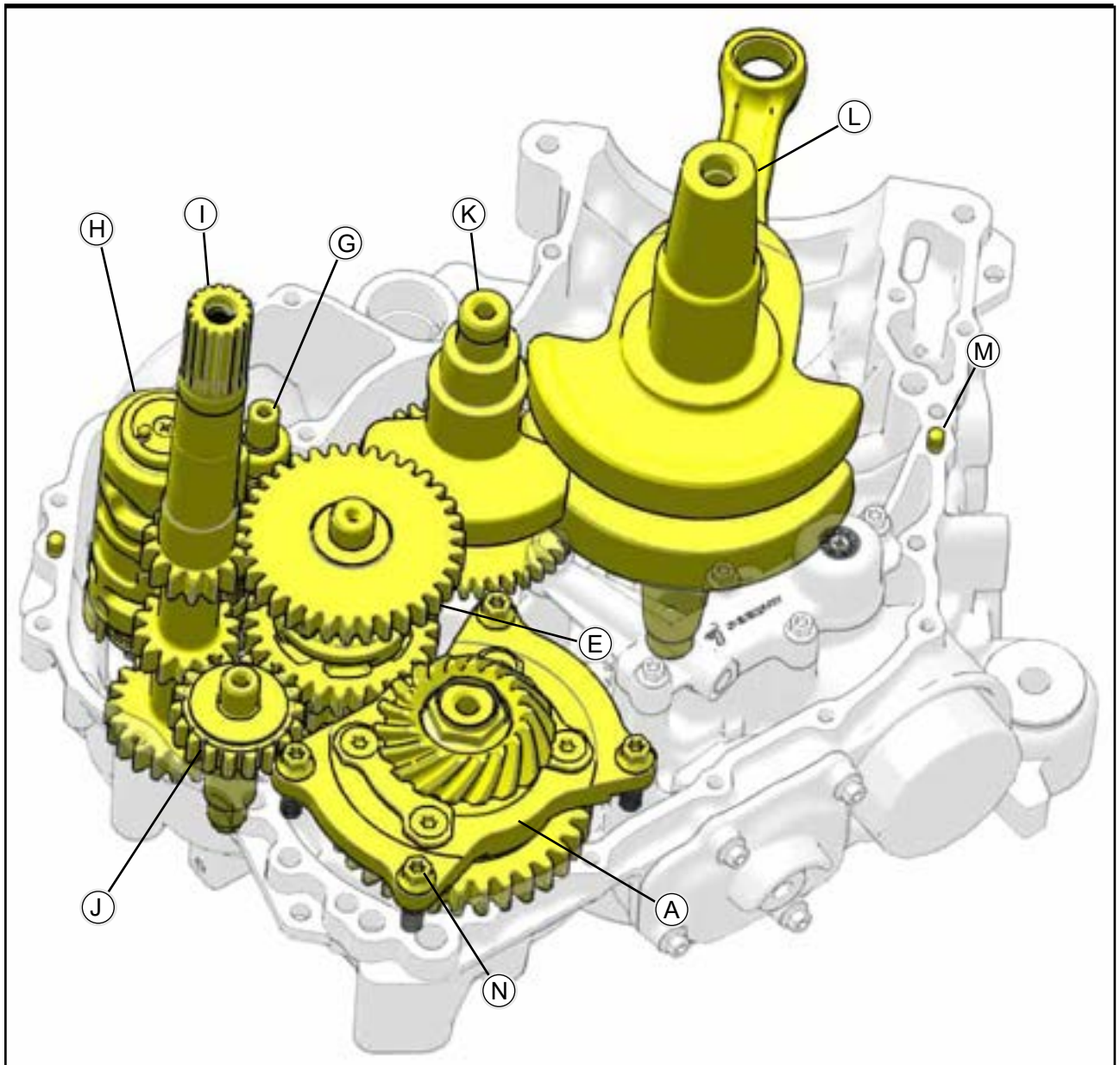

◆ Be sure the following parts are in place in the left crankcase half.

1. Drive Bevel Gear shaft Assembly 【A】
2. Parking Brake Arm 【B】 , Snap Ring 12 【C】 , Parking Brake Shaft 【D】
3. Countershaft Assembly 【E】 , Shift Rail L 【F】 , Shift Rail H/R 【G】 , Shift Drum 【H】
4. Transmission Main Shaft 【I】
5. R Idle Gear 【J】
6. Balance Shaft 【K】
7. Crankshaft 【L】
8. Dowel Pins 【M】
9. Bolt M8×30 【N】

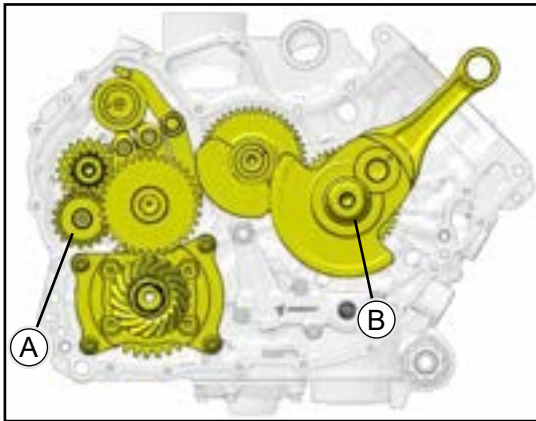

- ◆ Apply engine oil to the Needle Roller Bearing **【A】**, Crankshaft Rod **【B】**, Crankshaft Case oil passages, Main bearing bore **【E】**.

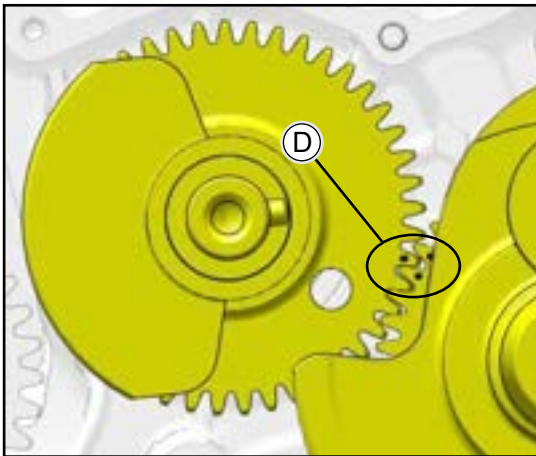

⚠ CAUTION

The Crankshaft and Balance Shaft Gear mark points **【D】** must be aligned.

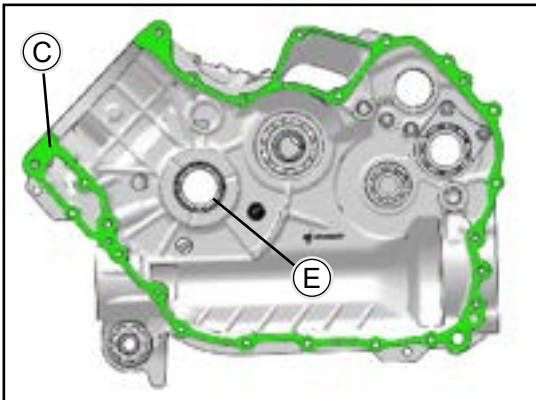

- ◆ Apply liquid gasket **【C】** to mating surface of the right crankcase half.

Sealant:5699

Apply after, must be assembled with in 5 min.

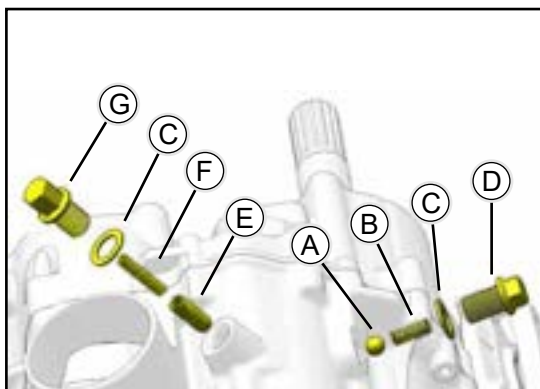
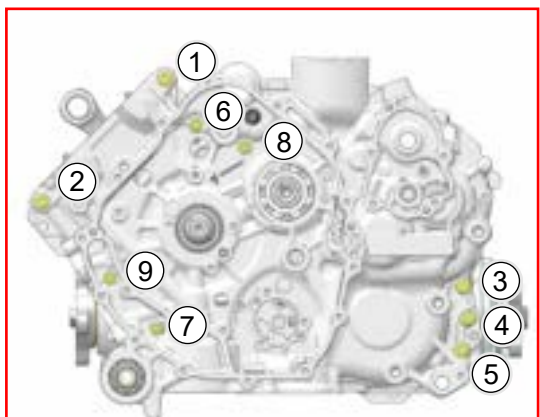
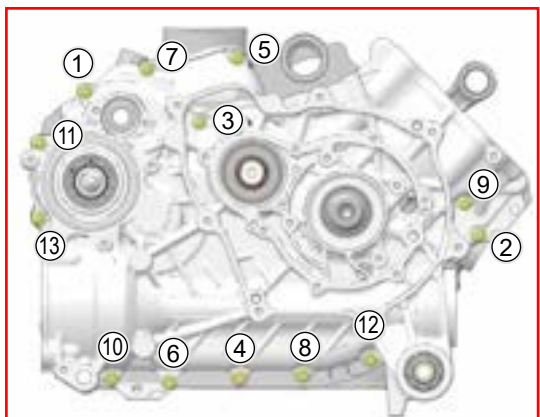
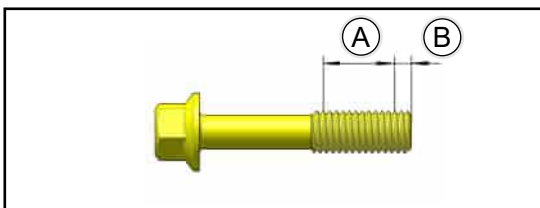

- ◆ Apply a non-permanent locking agent to the area **【A】** (12 mm, 0.47 in.) except for the tip **【B】** (2 ~ 3 mm, 0.08 ~ 0.12 in.).

Right Crankcase Bolt M6×40 **【13】**

- ◆ Tighten the right crankcase bolts (M6) following the tightening sequence **【1 ~ 13】**

Torque

Crankcase Bolts (M6)
9.8 N·m (1.0 kgf·m, 87 in·lb)

【1 ~ 13】 L = 40 MM

Left Crankcase : Bolt M8×70 **【2】**

Bolt M8×40 **【3】**

Bolt M6×65 **【4】**

- ◆ Tighten left crankcase bolts following the tightening sequence **【1 ~ 5】** (M8), **【6 ~ 9】** (M6)

Torque

Bolts (M6)	Bolts (M8)
9.8 N·m (1.0 kgf·m, 87 in·lb)	20 N·m (2.0 kgf·m, 14 ft·lb)

【1 ~ 2】 L = 70 mm

【3 ~ 5】 L = 40 mm

【6 ~ 9】 L = 65 mm

- ◆ Apply grease to the steel ball **【A】**, Parking Brake Pin **【E】** and spring **【B】** **【F】**.

- ◆ Install:

Steel Ball **【A】**

Spring **【B】**

washer **【C】**

Shift Spring Plug **【D】**

- ◆ Install:

Parking Brake Pin **【E】**

Parking Brake Arm Spring **【F】**

Washer **【C】**

Parking Brake Spring Plug **【G】**

- ◆ Tighten:

Torque

Shift Shaft Positioning Bolt
25 N·m (2.5 kgf·m, 18ft·lb)

- ◆ Check:

Crankshaft and driven shaft turn freely.

If any of the shafts do not turn freely, split the crankcase to locate the problem.

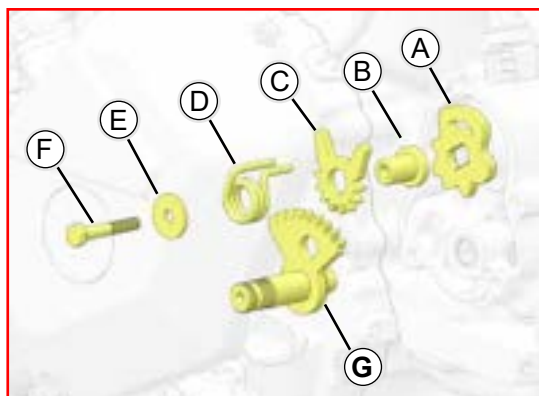

- ◆ Installation:
- 【A】 Shift positioning wheel
- 【B】 Bushing
- 【C】 Shift driven gear
- 【D】 Shift torsion spring
- 【E】 Washer 6.2×22×2
- 【F】 Hexagon head bolt
- 【G】 Shift shaft assembly
- 【L】 Cylindrical pin 6×10

- ◆ Tightening torque:

Hexagon head bolt M6×40 【F】
14 N·m (1.4 kgf·m, 10 ft·lb)

- ◆ Apply thread fastener to bolt 【F】 .

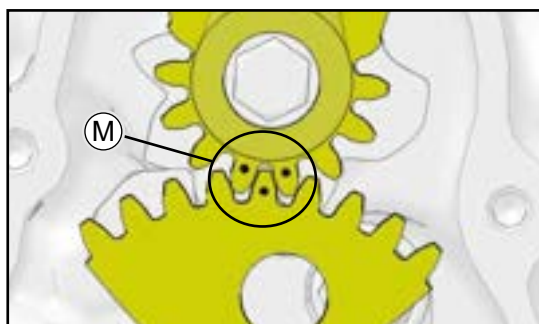
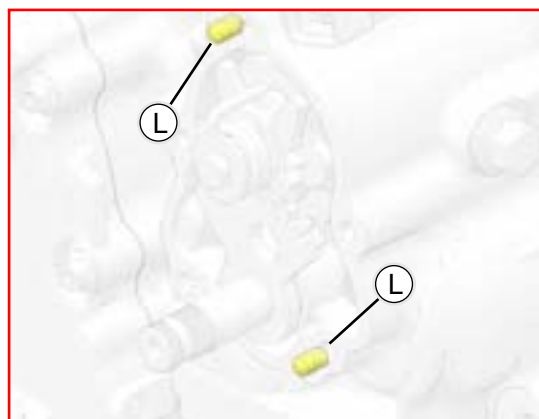

⚠ CAUTION

The shift shaft assembly and the shift driven gear marking point 【M】 must be aligned.

- ◆ Install:
- 【N】 Shiftshaft Cover Gasket
- 【O】 Shiftshaft Cover
- 【P】 Oil Seal 15×25×5
- 【Q】 Bolts M6×20

- ◆ Tighten:

Torque

Shiftshaft Cover Bolts 【Q】
9.8 N·m (1 kgf·m, 87 in·lb)

- ◆ Apply a non-permanent locking agent to the Bolts 【Q】

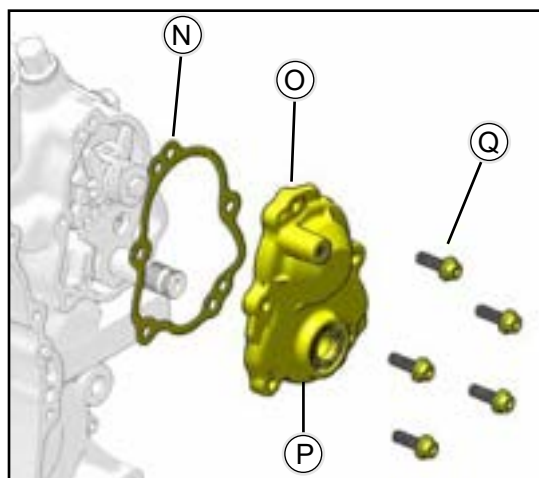

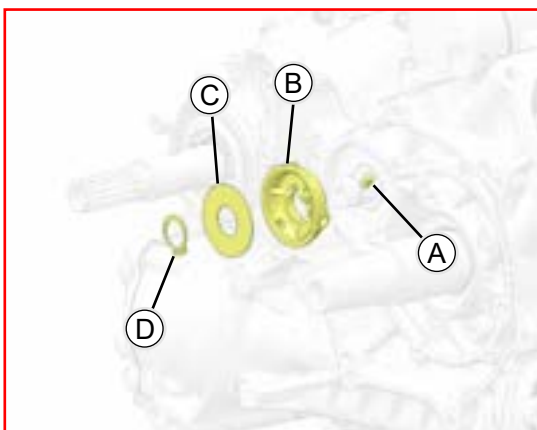

- ◆ Install:
- 【A】 Dowel Pin 6×10
- 【B】 Centrifugal Oil-air Separator
- 【C】 Washer
- 【D】 Snap Ring 25×1.2

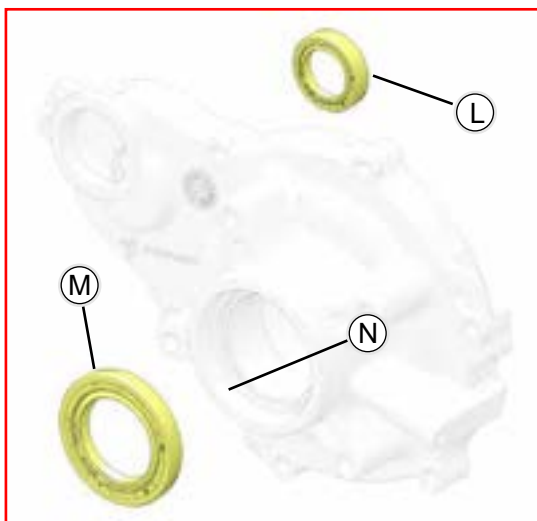

- ◆ Install:
- Oil Seal 20×30×7 【L】
- Oil Seal 35×52×7 【M】
- ◆ Apply engine oil to the Main bearing bore 【N】
- ◆ Apply grease the lip of the oil seal 【L】 and 【M】

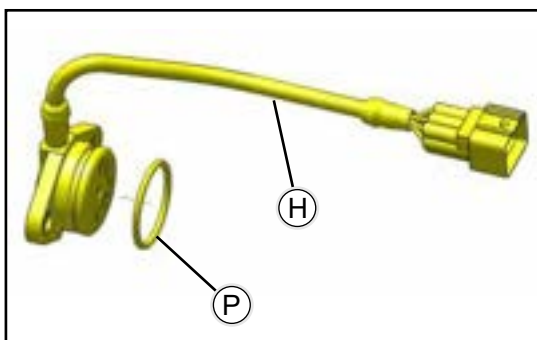

- ◆ Install:
- Put the O-Ring 29.6×2.4 【P】 into the Gear Sensor groove 【H】
- ◆ Apply engine oil to the O-Ring 29.6×2.4 【P】

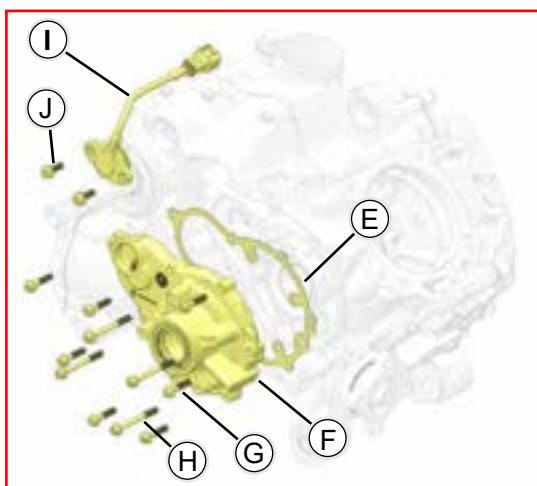

- ◆ Install:
- Right crankcase cover gasket 【E】
- Right crankcase cover assembly 【F】
- Bolt M6×30 【G】
- Bolt M6×60 【H】
- Gear sensor assembly 【I】
- Bolt M6×20 【J】

Tightening torque:

Bolt M6×30 【G】 /Bolt M6×20 【H】 /Bolt M6×20 【J】

9.8 N·m (1 kgf·m, 87 in·lb)

CRANKSHAFT

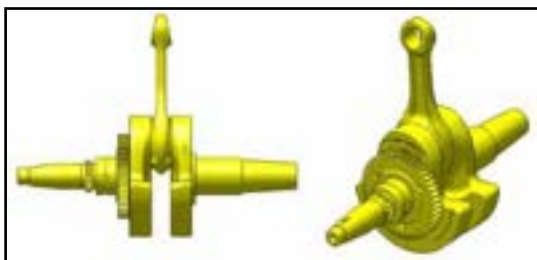

⚠ CAUTION

The Crankshaft and Connecting Rod are Assembled at the factory, so the Crankshaft must be replaced as a set.

CONNECTING ROD BIG END SIDE CLEARANCE

- ◆ Measure the side clearance of the connecting rod big end.
- ◆ Insert a thickness gauge **【B】** between the big end and either crank determine clearance.

Connecting Rod Big End Side Clearance

Standard: 0.13 ~ 0.48 mm

Service Limit: 0.7 mm

If the clearance exceeds the service limit, replace the Crankshaft.

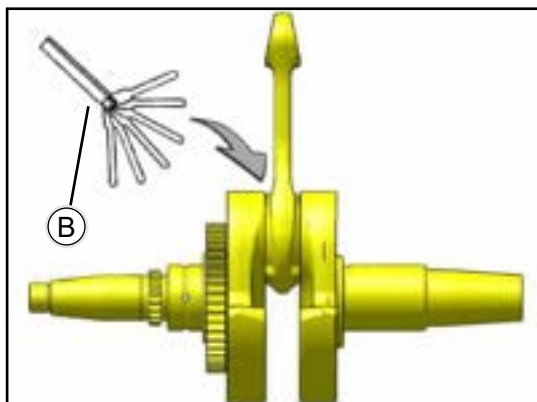

CRANKSHAFT RUNOUT

- ◆ Measure the crankshaft runout.

If the measurement exceeds the service limit, replace the Crankshaft.

Standard: TIR 0.04 mm (0.0016 in.) or less

Service Limit: TIR 0.10 mm (0.0039 in.)

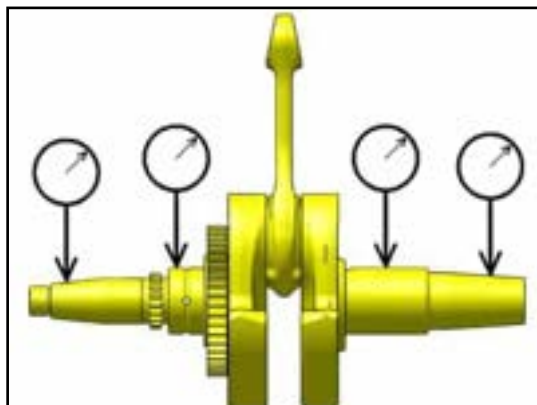

CRANKSHAFT MAIN BEARING/JOURNAL WEAR

- ◆ Measure the diameter **【A】** of the crankshaft main journal.

Crankshaft Main Journal Diameter

Standard: 40.995 ~ 41.005 mm

Service Limit: 40.97 mm

If any journal has worn past the service limit, replace the crankshaft with a new one.

- ◆ Measure the main bearing bore diameter **【B】** in the crankcase halves.

Crankcase Main Bearing Bore Diameter

Standard: 41.040 ~ 41.050 mm

Service Limit: 41.08 mm

If there is any signs of seizure, damage, or excessive wear, replace the crankcase halves as a set.

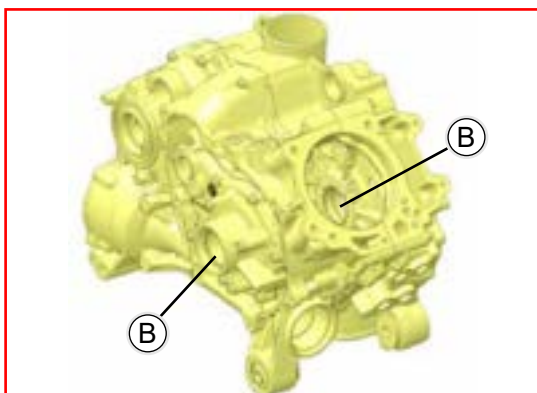
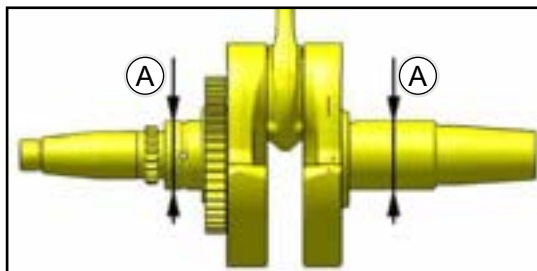

TRANSMISSION

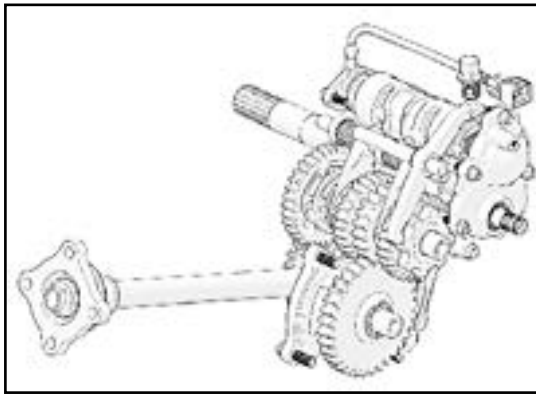

TRANSMISSION REMOVAL

- ◆ Remove the shift lever (see Shift Lever Removal).
- ◆ Remove the Shiftshaft (see Crankcase Disassembly).
- ◆ Split the crankcase (see Crankcase Disassembly).

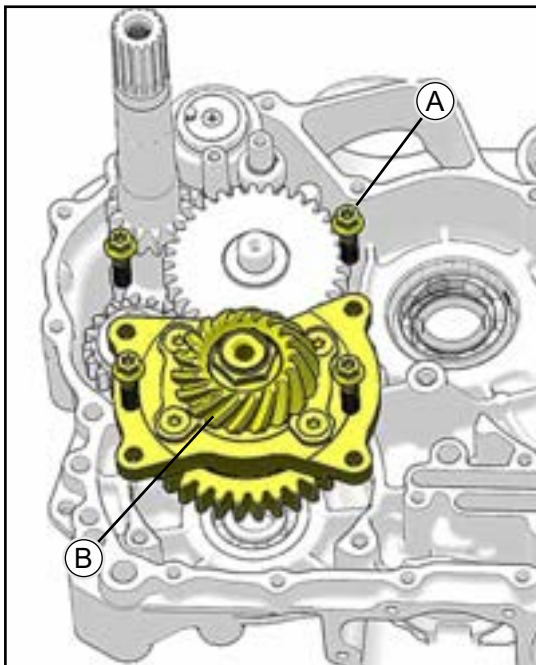

- ◆ Remove:
- Drive Bevel Gear Component Bolts 【A】
- Drive Bevel Gear Component 【B】

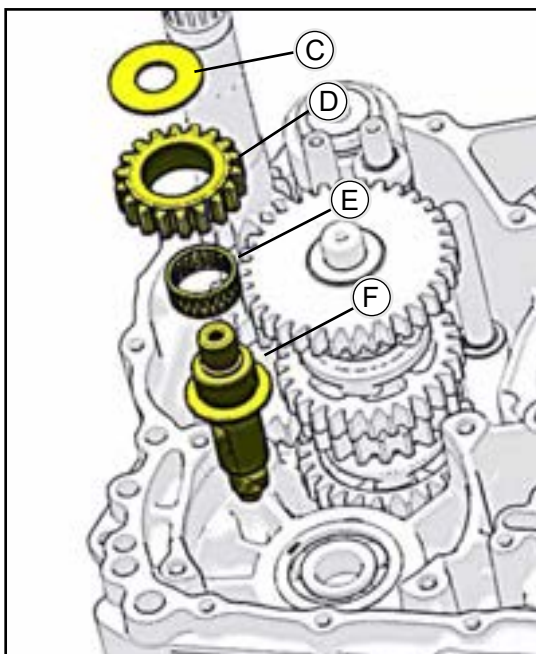

- ◆ Remove:
- Spacer 【C】
- Reverse Idle Gear 【D】
- Needle Bearing 【E】
- Reverse Idle Shaft 【F】

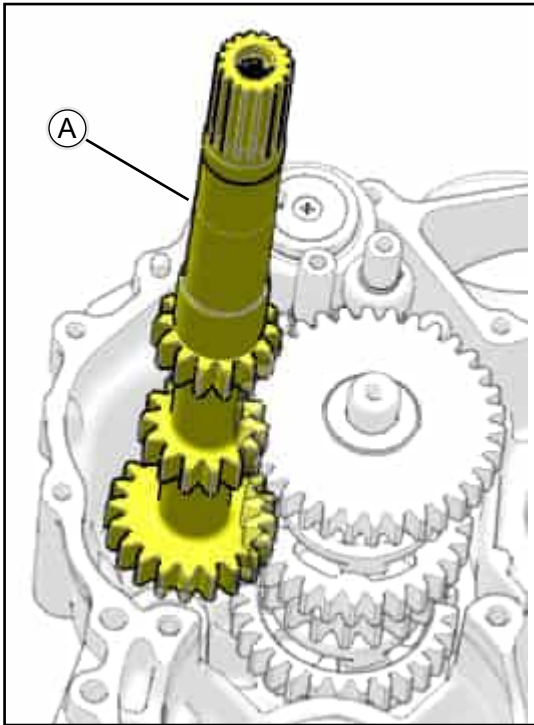

◆ Remove:
Main Shaft **【A】**

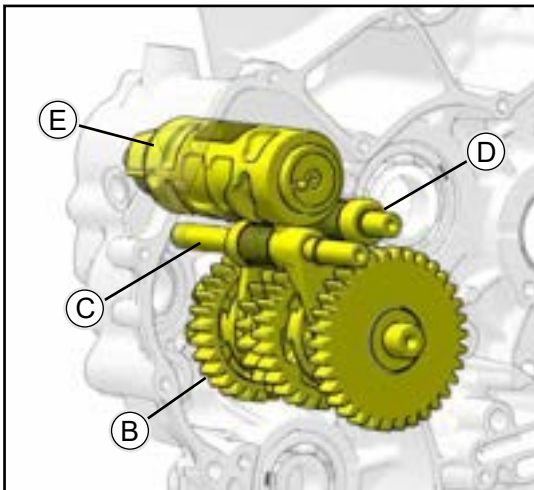

◆ Remove:
Countershaft Assembly **【B】** , Shift Rail L **【C】** , Shift Rail H/R **【D】** , Shift Drum **【E】** Component.

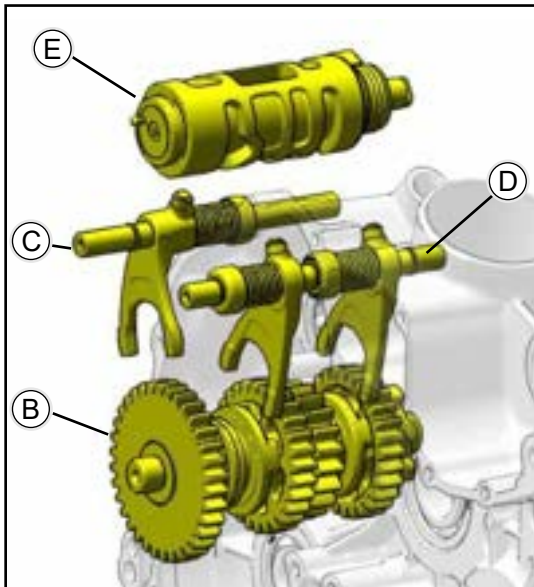

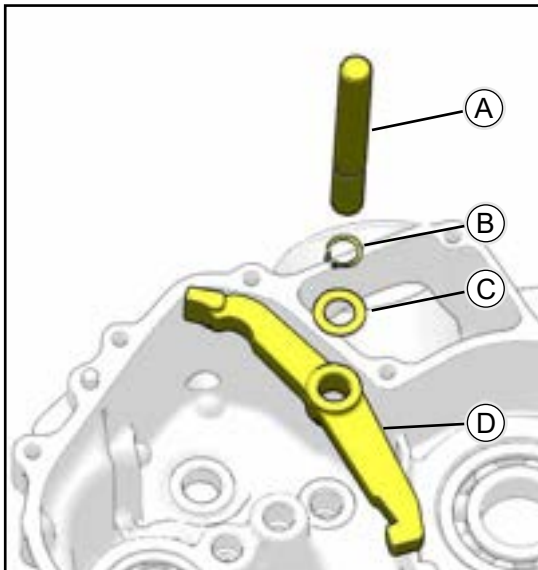

- ◆ Remove:
- Parking Brake Arm Shaft 【A】 and Snap Ring 12 【B】
- Spacer 12×20×1 【C】
- Parking Brake Arm 【D】



TRANSMISSION INSTALLATION

- ◆ Install:
- Insert the Parking Brake Arm Assembly in the crankcase until it is bottomed

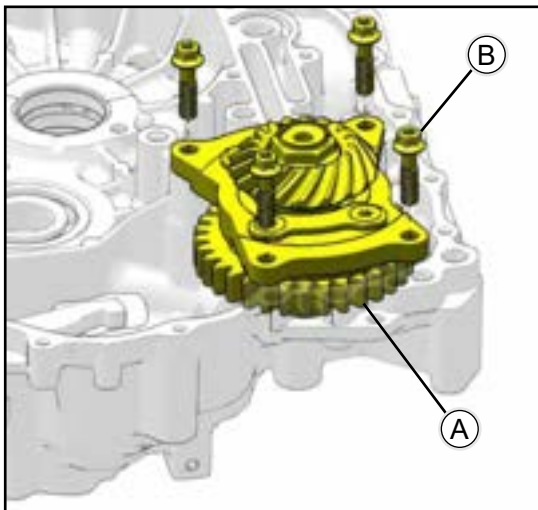

- ◆ Install:
- Drive Bevel Gear Assembly 【A】
- Bolts M8×30 【B】
- ◆ Apply a non-permanent locking agent to the area 【C】 (12 mm, 0.47 in.) except for the tip 【D】 (2 ~ 3 mm, 0.08 ~ 0.12 in.)

- ◆ Tighten:
- Torque**

Bolts M8×30 【B】
26 N·m (2.7 kgf·m, 20 ft·lb)

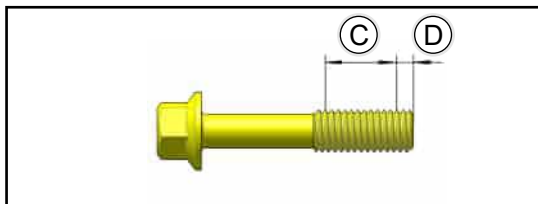

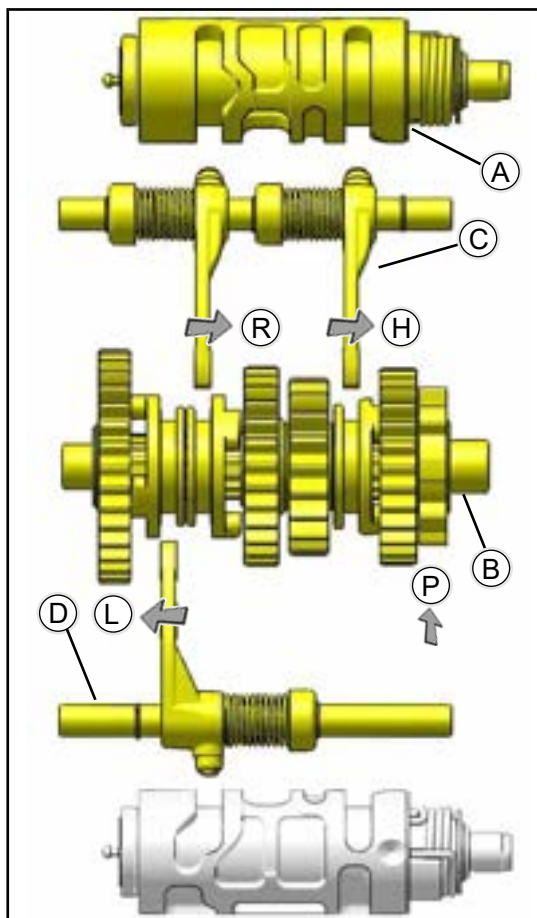

◆ Install:

Shift Rail Fork Assembly H/R 【A】

Shift Rail Fork Assembly L 【D】

Shift Drum 【A】

Countershaft Assembly 【B】

Insert the Shift Forks into the groove of the Countershaft Assembly

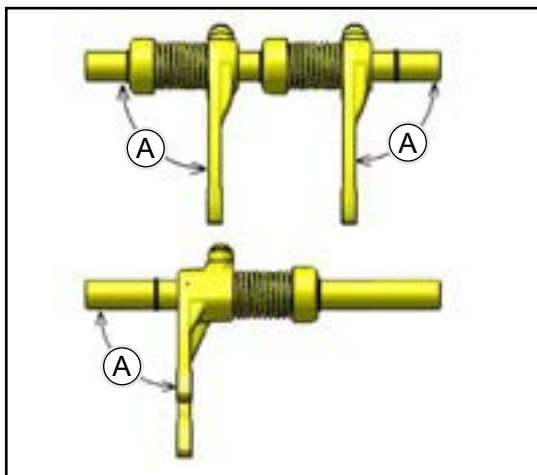

◆ Visually inspect the shift fork.

If the fork is bent, replace the shift rod with a new one. A bent fork could cause difficulty in shifting, or allow the transmission to jump out of gear when under power.

【A】 90°

SHIFT FORK/GEAR AND SHIFTER GROOVE WEAR

◆ Measure the thickness of the shift fork ears 【B】 , and measure the width 【C】 of the gear groove and shifter.

If the thickness of a shift fork ear is less than the servicelimit, the shift rod must be replaced.

Shift Fork Ear Thickness

Standard: 5.8 ~ 5.9 mm

Service Limit: 5.7 mm

If the groove is worn over the service limit, the shifter must be replaced

Shifter Groove Width

Standard: 6.0 ~ 6.1 mm

Service Limit: 6.2 mm

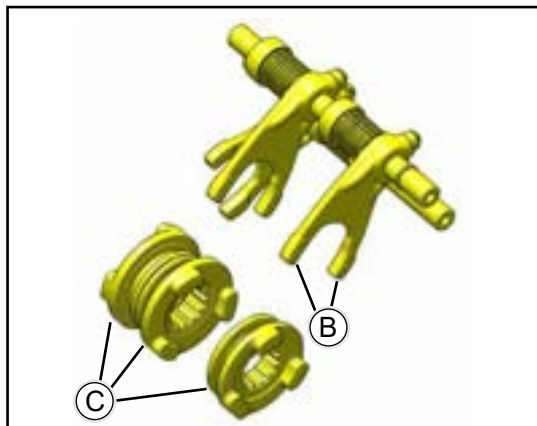

**TRANSMISSION AND SHIFT MECHANISM
INSPECTION**

◆ Visually inspect:

Gears

Dogs of Gear and Shifter

If they are damaged or worn excessively, replace them



◆ Install:

1. Install the Countershaft Assembly, Shift Rail L, Shift Rail H/R and Shift Camshaft to C.

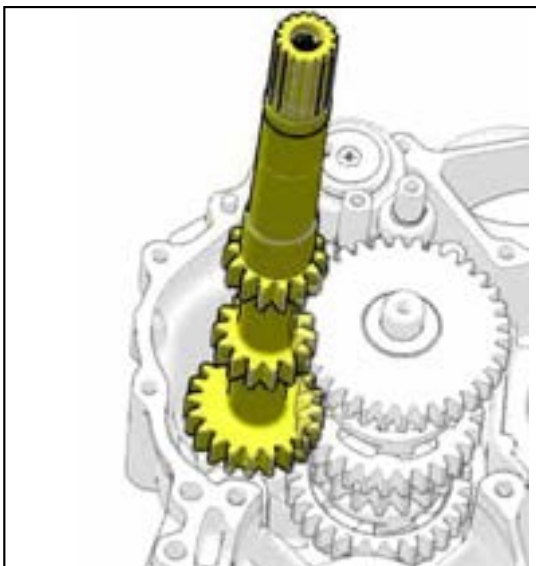

2. Transmission Main Shaft

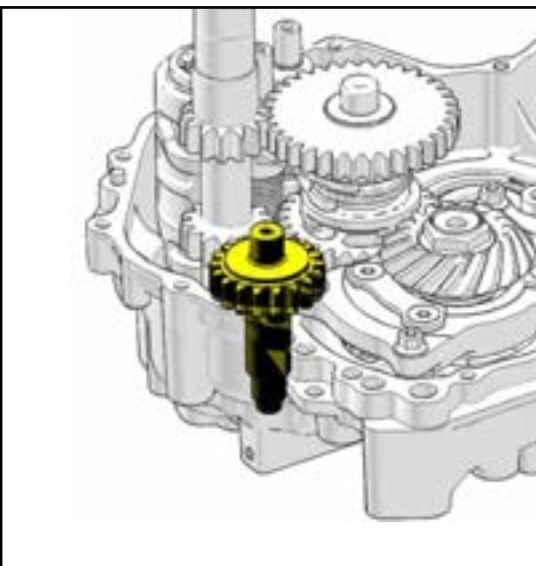

3. R Idle Gear Shaft Assembly

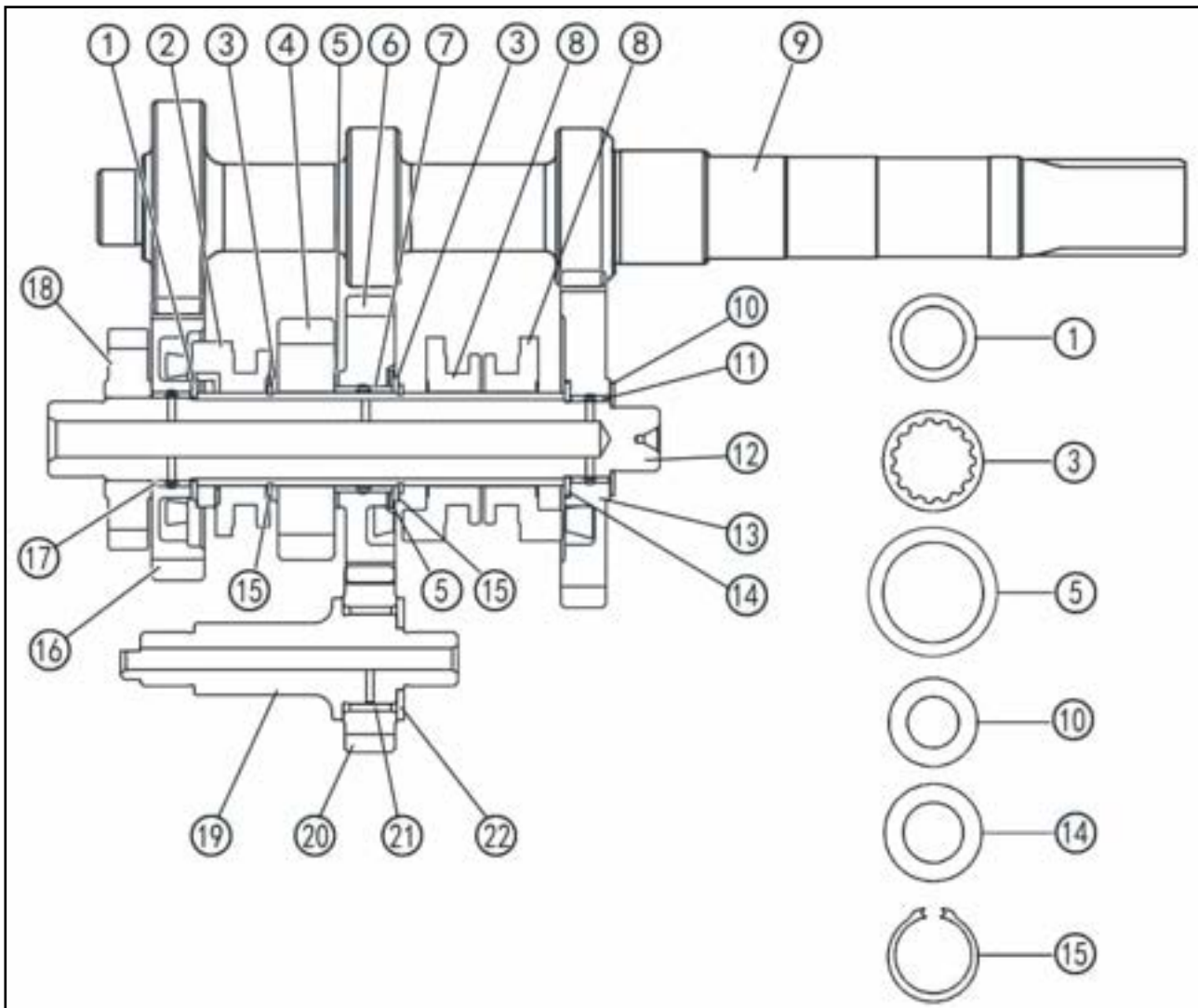

1	Spacer 22×32×1.5	12	Countershaft
2	Shifter, H	13	L gear driven gear
3	Washer 33×1.5	14	Washers 20×30×1.5
4	Reduction drive gear	15	Elastic retaining ring 25×1.2
5	Spacer 28×36.5×1	16	H gear driven gear
6	Gear R	17	H bushing
7	Bushing R	18	Parking gear
8	Shifter, R/L	19	Reverse gear intermediate wheel shaft
9	Main Shaft	20	Reverse gear
10	Spacer 17×30×1	21	Needle roller bearings
11	Bushing L	22	Washers 17×38×2

BALL BEARING, NEEDLE BEARING, AND OIL SEAL

BALL AND NEEDLE BEARING REPLACEMENT

⚠ CAUTION

Do not remove the ball or needle bearings unless it is necessary. Removal may damage them.

- ◆ Using a press or puller, remove the ball bearing and/or three needle bearings.

NOTE

In the absence of the above mentioned tools, satisfactory results may be obtained by heating the case to approximately 93°C (200°F) max., and tapping the bearing in or out.

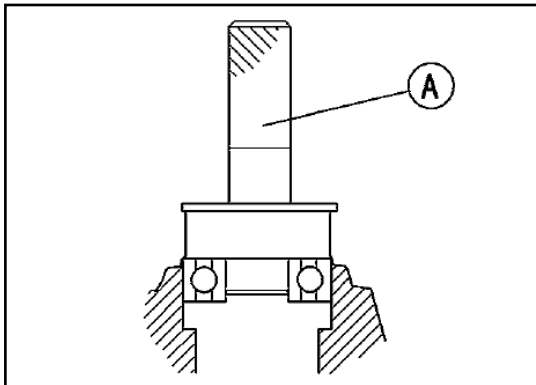

⚠ CAUTION

Do not heat the case with a torch. This will warp the case. Soak the case in oil and heat the oil.

Using a press and the bearing driver set **【A】**, install the new ball bearing until it stops at the bottom of its housing.

Special Tool - Bearing Driver Set

BALL AND NEEDLE BEARING WEAR

⚠ CAUTION

Do not remove the bearings for inspection. Removal may damage them.

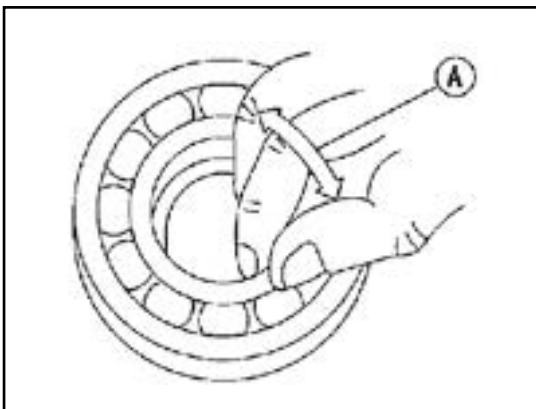

- ◆ Check the ball bearings.

Since the ball bearings are made to extremely close tolerances, the wear must be judged by feel rather than measurement. Clean each bearing in a high flash-point solvent, dry it (do not spin the bearing while it is dry), and oil it with engine oil.

Spin **【A】** the bearing by hand to check its condition.

If the bearing is noisy, does not spin smoothly, or has any rough spots, replace it.

◆ Check the needle bearings.

The rollers in a needle bearing normally wear very little, and wear is difficult to measure. Instead of measuring, inspect the bearing for abrasion, color change, or other damage. Spin **【A】** the bearing by hand to check its condition.

If there is any doubt as to the condition of a needle bearing, replace it.

OIL SEAL INSPECTION

◆ Inspect the oil seals.

Replace it if the lips are misshapen, discolored (indicating that the rubber has deteriorated), hardened or otherwise damaged.

ENGINE-ELECTRICAL SYSTEM

EXPLODED VIEW.....	3-3-2
TECHNICAL PARAMETER	3-3-4
SPECIAL TOOLS	3-3-5
CHARGING SYSTEM.....	3-3-6
ALTERNATOR COVER REMOVAL.....	3-3-6
ALTERNATOR COVER INSTALLATION	3-3-6
ALTERNATOR ROTOR REMOVAL.....	3-3-7
ALTERNATOR ROTOR INSTALLATION.....	3-3-8
ALTERNATOR STATOR REMOVAL.....	3-3-8
ALTERNATOR STATOR INSTALLATION.....	3-3-9
ALTERNATOR INSPECTION.....	3-3-10
ALTERNATOR OUTPUT VOLTAGE.....	3-3-10
STATOR COIL RESISTANCE	3-3-11
ELECTRIC STARTER SYSTEM.....	3-3-12
STARTER MOTOR REMOVAL	3-3-12
STARTER MOTOR INSTALLATION.....	3-3-12
ONE-WAY CLUTCH REMOVAL.....	3-3-13
ONE-WAY CLUTCH INSTALLATION	3-3-13
ONE-WAY CLUTCH INSPECTION	3-3-13
STARTER GEAR REMOVAL.....	3-3-14
STARTER GEAR INSTALLATION.....	3-3-14

EXPLODED VIEW

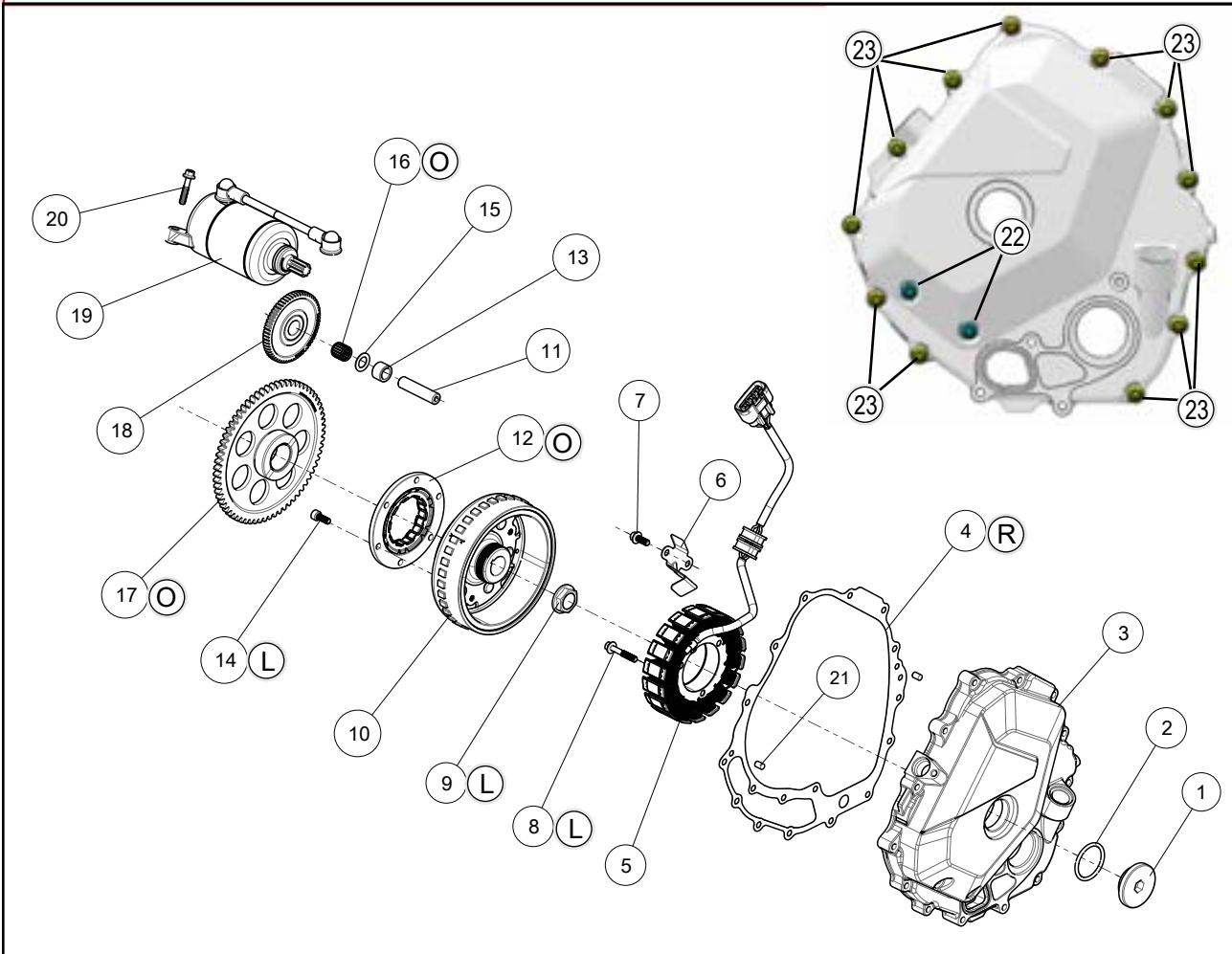

ENGINE-ELECTRICAL SYSTEM

SEGWAY AT5

No.	Name	Torque			Remarks
		N·m	kgf·m	ft·lb	
1	Stator Cover Plug	18	1.8	13.3	
2	O-Ring 35×3.5				
3	Left Crankcase Cover				
4	Left Crankcase Cover Gasket				R
5	Alternator Stator				
6	Plate				
7	Bolt M6×16	9.8	1.0	87 in·lb	
8	Bolt M6×35	10	1.0	7.4	L
9	Nut M18×1.5	180	18.4	133	L
10	Alternator Rotor				
11	Double Gear Shaft				
12	One-Way Clutch				O
13	Spacer 12×18×12				
14	Bolt M6×16	18	1.8	13.3	L
15	Spacer 12×20×1				
16	Needle Roller Bearing K121616				O
17	Starting Driven Gear Assembly				O
18	Double Gear Assembly				
19	Starter Motor Assembly				
20	Bolt M6×30	9.8	1.0	87 in·lb	
21	Dowel Pin 6×10				
22	Bolt M6×55	9.8	1.0	87 in·lb	
23	Bolt M6×30	9.8	1.0	87 in·lb	

G: Apply grease for oil seal and O-ring.

L: Apply a non-permanent locking agent.

O: Apply engine oil.

R: Replacement Parts.

TECHNICAL PARAMETER

Item	Standard	Service Limit
Charging System:		
Alternator type	Three-phase AC	---
Charging voltage (Regulator/rectifier output voltage)	14 ~ 15V	---
Alternator output voltage:	36 ~ 54V 3000r/min(rpm)	---
Stator coil resistance:	0.33 ~ 0.49 Ω	---

SPECIAL TOOLS

Flywheel Puller Assembly :
E01GZ0010001

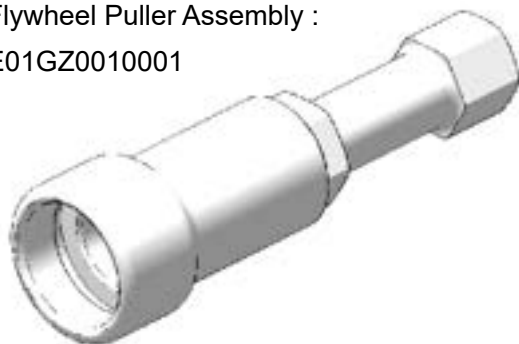

Flywheel Holder:

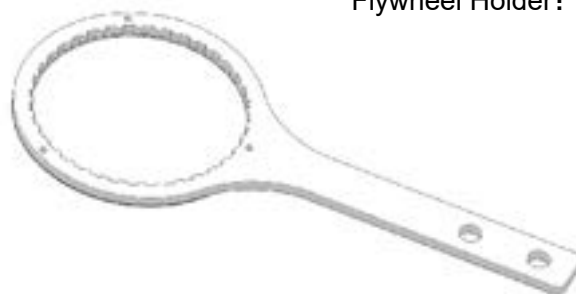

CHARGING SYSTEM

ALTERNATOR COVER REMOVAL

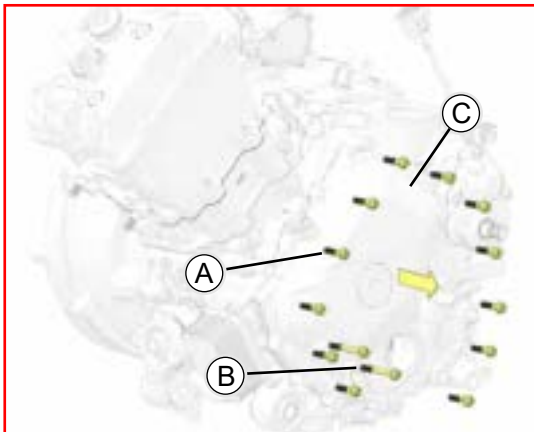

- ◆ Place an coolant pan under the engine left side.
- ◆ Drain the coolant (see Cooling System chapter).
- ◆ Place an oil pan under the engine left side.
- ◆ Remove Water Pump (see Cooling System chapter).
- ◆ Remove:

Alternator and Crankshaft Sensor Lead Connectors (disconnect)

- 【A】 Bolts M6×30 (12)
- 【B】 Bolts M6×55 (2)
- 【C】 Alternator Cover

ALTERNATOR COVER INSTALLATION

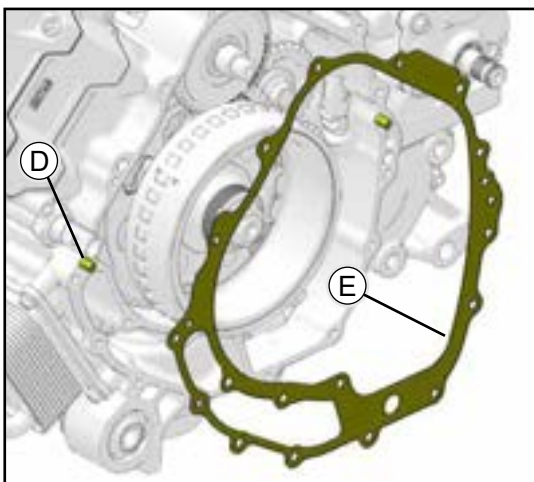

- ◆ Be sure all of the old gasket has been removed from the alternator cover and the left crankcase sealing surfaces.
- ◆ Check that the Dowel Pins 【D】 are in place, and fit a new gasket 【E】 on the crankcase.

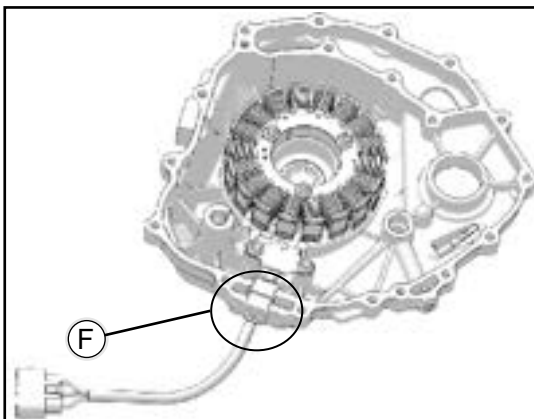

- ◆ Fit the grommets 【F】 into the notch in the cover.

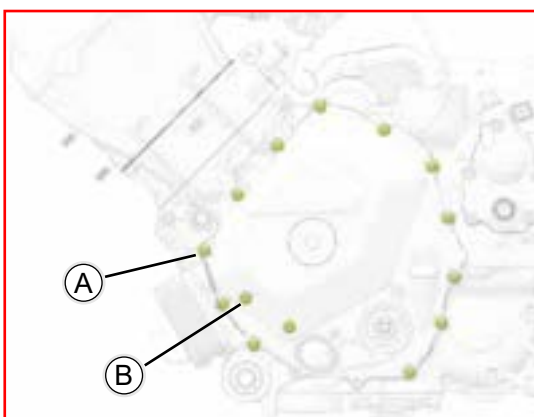

- ◆ Install the Alternator Cover bolts 【A】 and 【B】
- ◆ Tighten

Torque

Alternator Cover Bolts
9.8 N·m (1.0kgf·m, 87 in·lb)

- ◆ Install Water Pump (see Cooling System chapter).

ALTERNATOR ROTOR REMOVAL

◆ Remove:

1. Alternator Cover (see Alternator Cover Removal)
2. Alternator rotor Nut M18×1.5 【A】
3. Thread the flywheel puller 【B】 onto the alternator rotor.

**Special Tool - Flywheel Puller:E01GZ0010001
Flywheel Holder**

- ◆ Holding the Flywheel Holder 【B】 , turn the rotor puller 【C】 until the alternator rotor is forced off the end of the crankshaft.

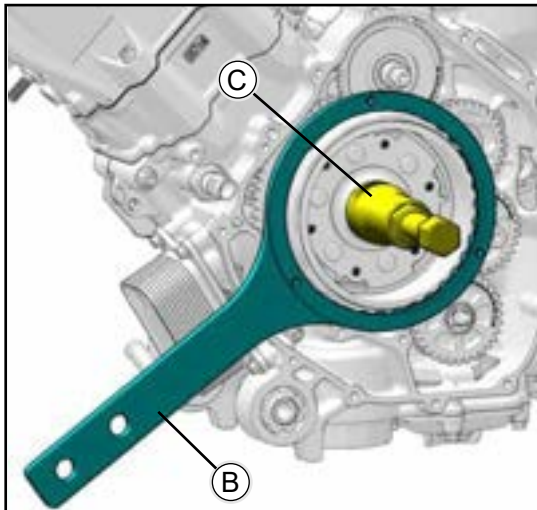
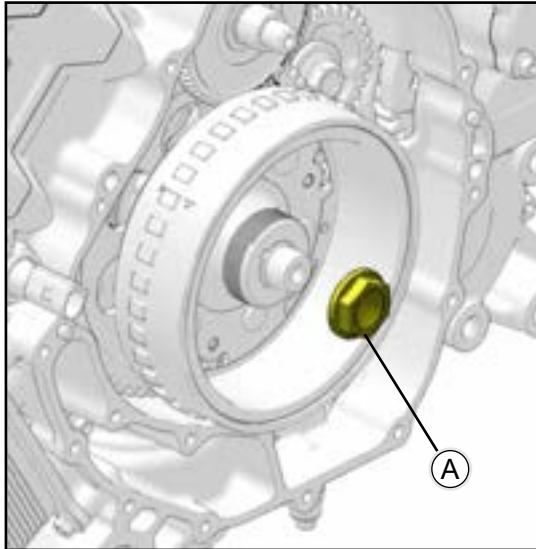
**⚠ CAUTION**

If the rotor is difficult to remove, turn the puller while tapping the end of the puller. Do not strike the alternator rotor. Striking the rotor can cause the magnets to lose magnetism.

ALTERNATOR ROTOR INSTALLATION

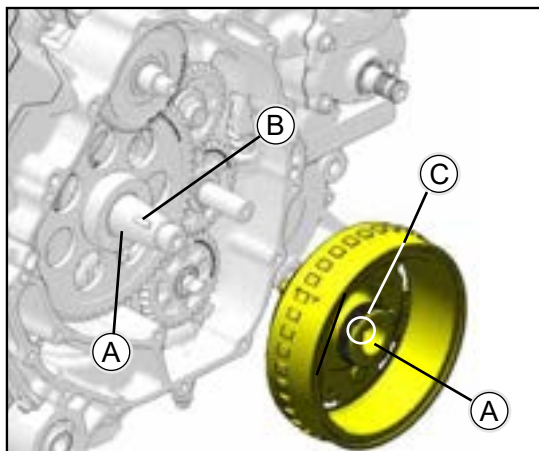

- ◆ Clean **【A】** the inside of the rotor and the end of the crankshaft.
- ◆ Fit the rotor onto the crankshaft so that woodruff key **【B】** fits in the groove **【C】** in the hub of the rotor.
- ◆ Install the alternator rotor **【B】** while turning the starter clutch gear **【C】** .

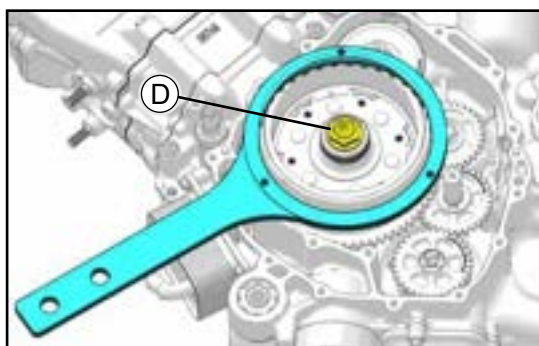

- ◆ Nut M18×1.5 **【D】**
- ◆ Tighten:

Torque

Nut 【C】
180 N•m (18.4 kgf•m, 133 ft•lb)

- ◆ Apply a non-permanent locking agent to the Nut **【C】** .

Special Tool - Flywheel Holder

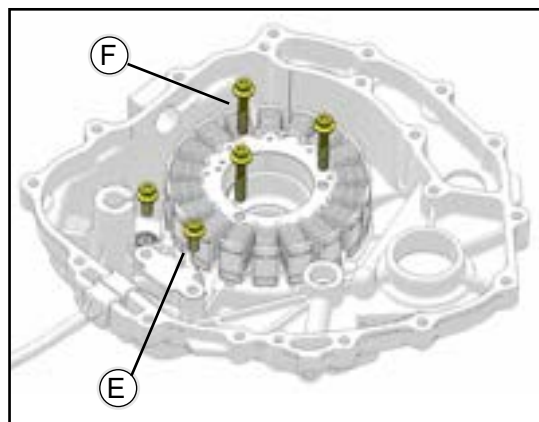

ALTERNATOR STATOR REMOVAL

- ◆ Remove:

Left Crankcase Cover (see Left Crankcase Cover Removal)

Bolts M6×16 (2) **【E】**

Bolts M6×35 (3) **【F】**

Alternator Stator **【G】**

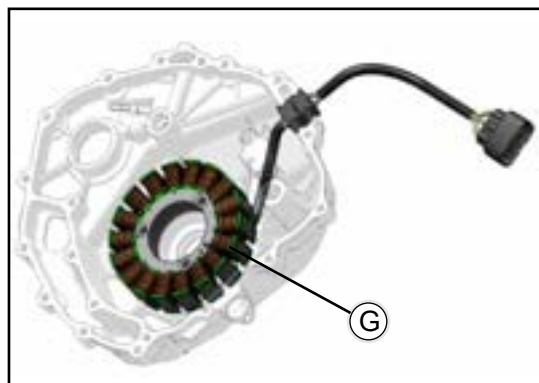

ALTERNATOR STATOR INSTALLATION

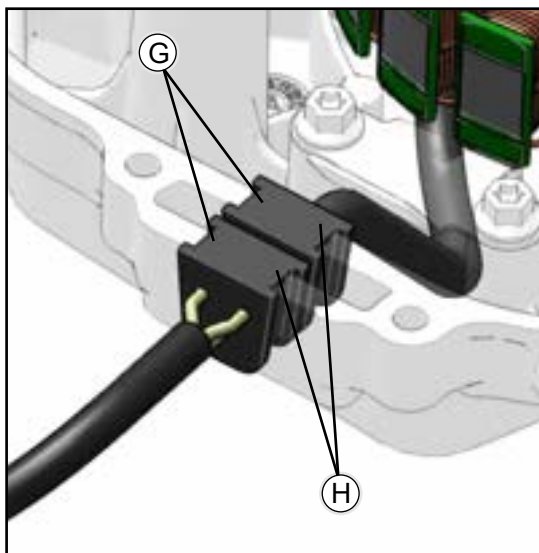
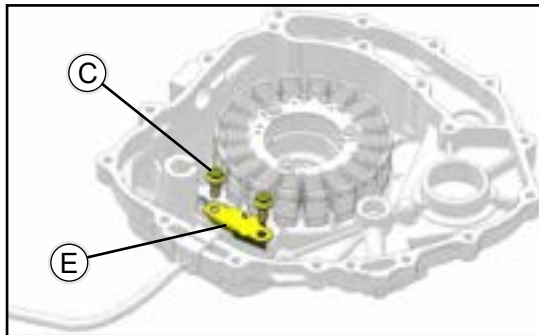
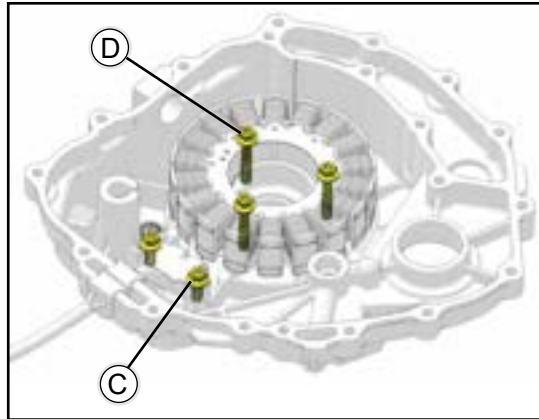
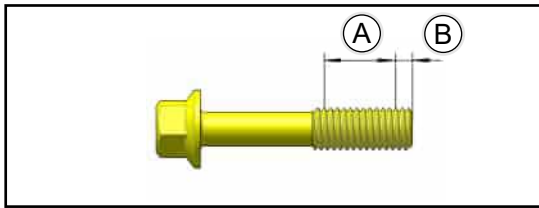

- ◆ Apply a non-permanent locking agent to the area **【A】** (12 mm, 0.47 in.) except for the tip **【B】** (2 ~ 3 mm, 0.08 ~ 0.12 in.)

- ◆ Tighten:

Torque

Bolts M6×35
9.8 N•m (1.0 kgf•m, 87in•lb)

Bolts M6×16
9.8 N•m (1.0 kgf•m, 87in•lb)

- ◆ Install:

Crankshaft Sensor (see Crankshaft Sensor Installation)

- ◆ Fit the lead grommets **【G】** into the notch on the Left Crankcase Cover.

- ◆ Fit the Plate **【E】**

- ◆ Apply liquid gasket **【H】** to mating surface of the lead grommets.

Sealant:5699

Apply after, must be assembled with in 5 min.

ALTERNATOR INSPECTION

There are three types of alternator failures: short, open, or loss in rotor magnetism. A short or open in one of the coil wires will result in either a low output, or no output at all. A loss in rotor magnetism, which may be caused by dropping or hitting the alternator, by leaving it near an electromagnetic field, or just by aging, will result in low output.

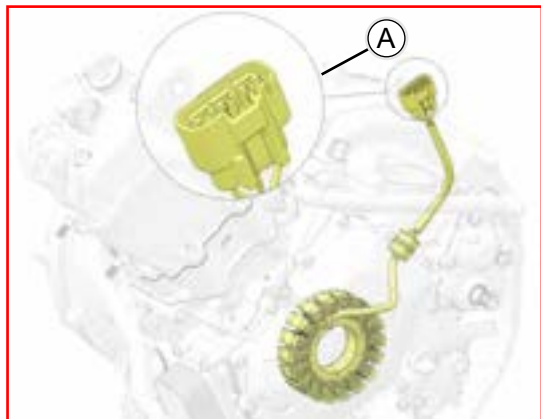

- ◆ To check the alternator output voltage, perform the following procedures.
- ◆ Disconnect the alternator connector **【A】**.
- ◆ Connect a hand tester as shown in the table.
- ◆ Start the engine.
- ◆ Run it at the rpm given in the table.
- ◆ Note the voltage readings (total 3 measurements).

ALTERNATOR OUTPUT VOLTAGE

Tester Range	Connections		Reading @3000rpm
	Tester (+) to	Tester (-) to	
250V AC	One yellow lead	Another yellow lead	36~54 V

If the output voltage is within the values in the table, the alternator is operating correctly, and the regulator/rectifier is damaged. A much lower reading indicates that the alternator is defective.

- ◆ Check the stator coil resistance as follows:
- ◆ Stop the engine.
- ◆ Disconnect the alternator connector.
- ◆ Connect a hand tester as shown in the table.
- ◆ Note the readings (total 3 measurement).

STATOR COIL RESISTANCE

Tester Range	Connections		Reading
	Tester (+) to	Tester (-) to	
$\times 1\Omega$	One yellow lead	Another yellow lead	0.33~0.49 Ω

If there is more resistance than shown in the table, or no reading (infinity) for any two leads, the stator has an open and must be replaced. Much less resistance means the stator is shorted and must be replaced.

- ◆ Using the highest resistance range of the hand tester, measure the resistance between each of the black leads and chassis ground.
- ◆ Any reading less than infinity (∞) indicates a short, necessitating stator replacement.

If the stator coils have normal resistance, but the voltage check shows the alternator to be defective, then the rotor magnetism has probably weakened, and the rotor must be replaced.

Special Tool - Hand Tester :

ELECTRIC STARTER SYSTEM

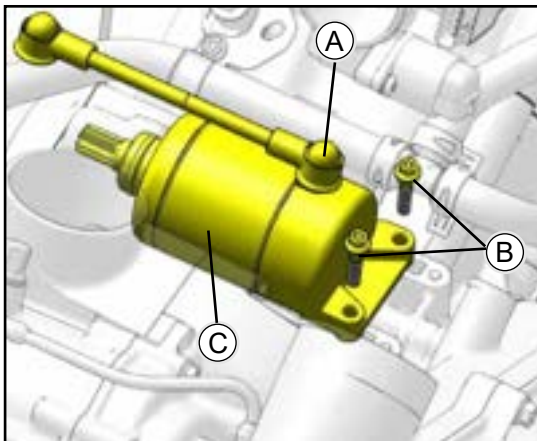

STARTER MOTOR REMOVAL

- ◆ Remove
 - Starter Motor Cable 【A】
 - Starter Motor Mounting Bolts 【B】
 - Starter Motor 【C】

⚠ CAUTION

Do not tap the end of the starter motor shaft or the motor may be damaged.

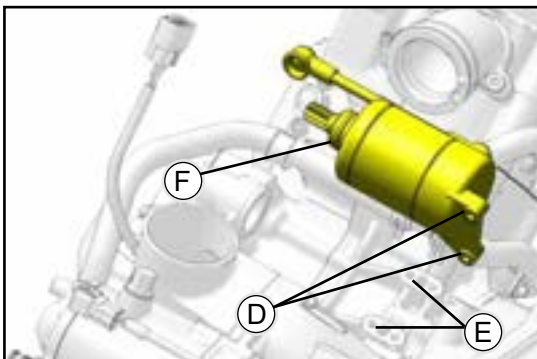

STARTER MOTOR INSTALLATION

- ◆ When installing the starter motor, clean the starter motor lugs 【D】 and crankcase 【E】 where the starter motor is grounded.

If the O-ring 【F】 shows wear or damage, or if it is hardened, replace it with a new one.

- ◆ Apply a small amount of engine oil to the O-ring.
- ◆ Install:
 - Starter Motor 【C】
 - Starter Motor Cable 【A】

- ◆ Tighten:

Torque

StarterMotorMounting Bolts
9.8N•m(1.0 kgf•m, 87 in•lb)

Starter Motor Terminal Nut
4.9 N•m (0.50 kgf•m, 43 in•lb)

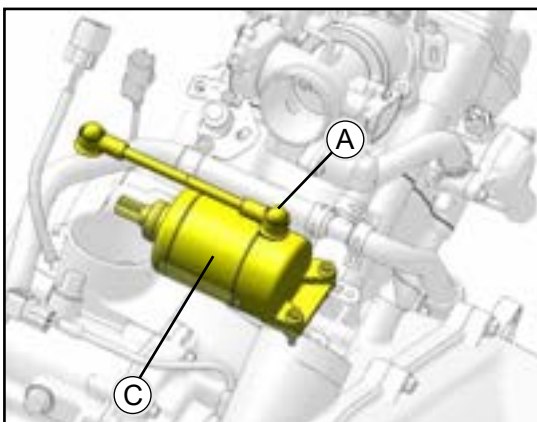

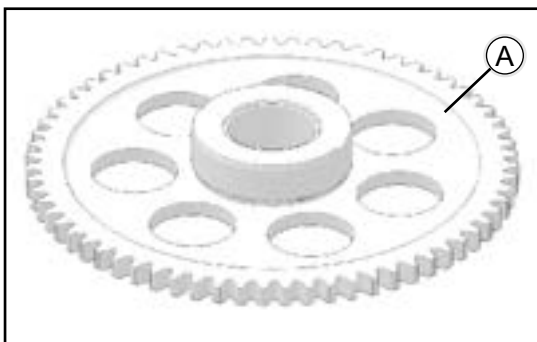
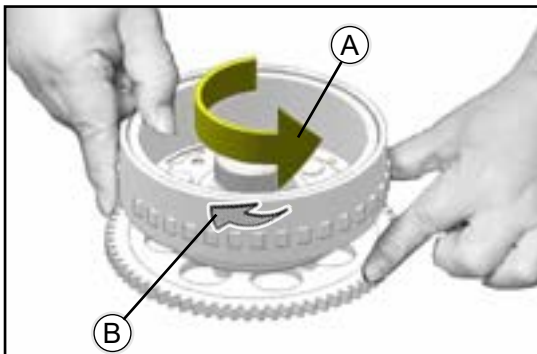
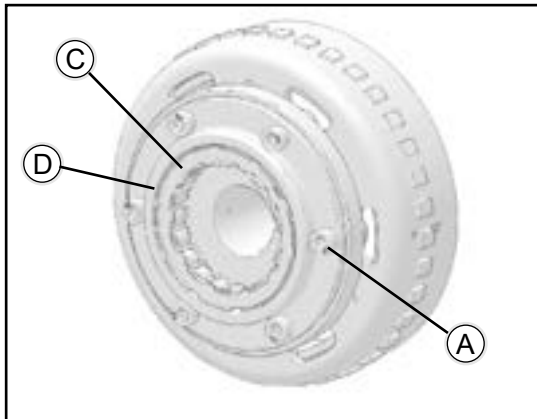
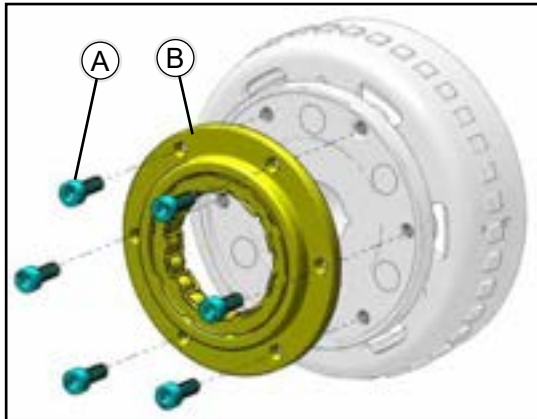

ONE-WAY CLUTCH REMOVAL

- ◆ Remove the Alternator Rotor (see Alternator Rotor Removal).
- ◆ Hold the rotor with the Flywheel Holder and take out the One-Way Clutch Bolts 【A】 .
- ◆ Take out the One-Way Clutch 【B】 .

ONE-WAY CLUTCH INSTALLATION

- ◆ Install the One-Way Clutch so that the flange 【C】 fits on the recess 【D】 of the race.
- ◆ Apply a non-permanent locking agent: One-Way Clutch Bolts 【A】
- ◆ Tighten:

Torque

Bolts 【A】
18 N•m (1.8 kgf•m, 13.3 ft•lb)

ONE-WAY CLUTCH INSPECTION

- ◆ Remove:
Alternator Rotor (see Alternator Rotor Removal)
- ◆ Fit the Starter One-Way Gear into the One-Way Clutch.

If the alternator rotor turns counterclockwise 【A】 freely from the Starter One-Way Gear, but not clockwise 【B】 , the clutch is operating correctly.

If the clutch does not operate correctly, or if it makes noise, disassemble it and examine each part visually. Replace any worn or damaged parts.

NOTE

Examine the Starter One-Way Gear 【A】 . Replace it if it is worn or damaged.

STARTER GEAR REMOVAL

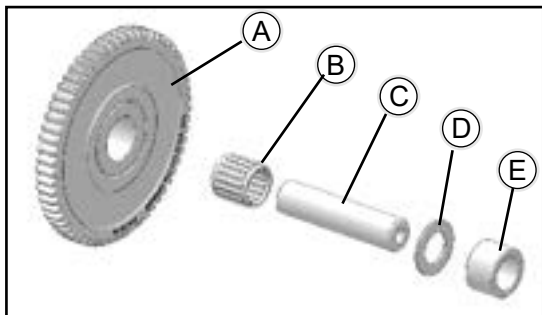

◆ Remove

1. Alternator Rotor (see Alternator Rotor Removal)
2. Spacer **【E】**
3. Washer **【D】**
4. Double Gear Shaft **【C】**
5. Needle Roller Bearing **【B】**
6. Remove the Starter Gear Assembly **【A】**

Visually inspect the Starter Gear

If the gear does not operate correctly, or if it makes noise, disassemble it and examine each part visually. Replace any worn or damaged parts.



STARTER GEAR INSTALLATION

◆ Install

1. Starter Gear Assembly **【A】**
2. Install the Needle Roller Bearing **【B】** , Apply engine oil to the Needle Roller Bearing
3. Combine the Spacer **【C】** , Spacer **【D】** and Double Gear Shaft **【E】** install them to mounting hole of the Crankcase.

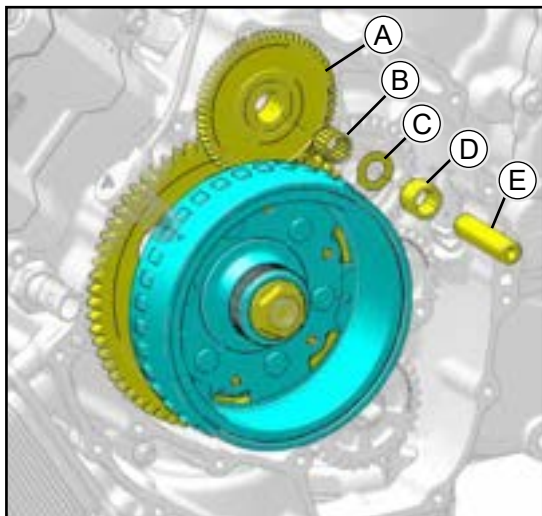

ENGINE-COOLING SYSTEM

EXPLODED VIEW.....	3-4-2
TECHNICAL PARAMETER	3-4-4
WATER PUMP	3-4-5
WATER PUMP REMOVAL	3-4-5
WATER PUMP INSTALLATION	3-4-5
THERMOSTAT	3-4-6
THERMOSTAT REMOVAL	3-4-6
THERMOSTAT INSTALLATION	3-4-6
THERMOSTAT INSPECTION	3-4-7
COOLANT TEMPERATURE SENSOR	3-4-8
COOLANT TEMPERATURE SENSOR REMOVAL.....	3-4-8
COOLANT TEMPERATURE SENSOR INSTALLATION	3-4-8
COOLANT TEMPERATURE SENSOR INSPECTION	3-4-8

EXPLODED VIEW

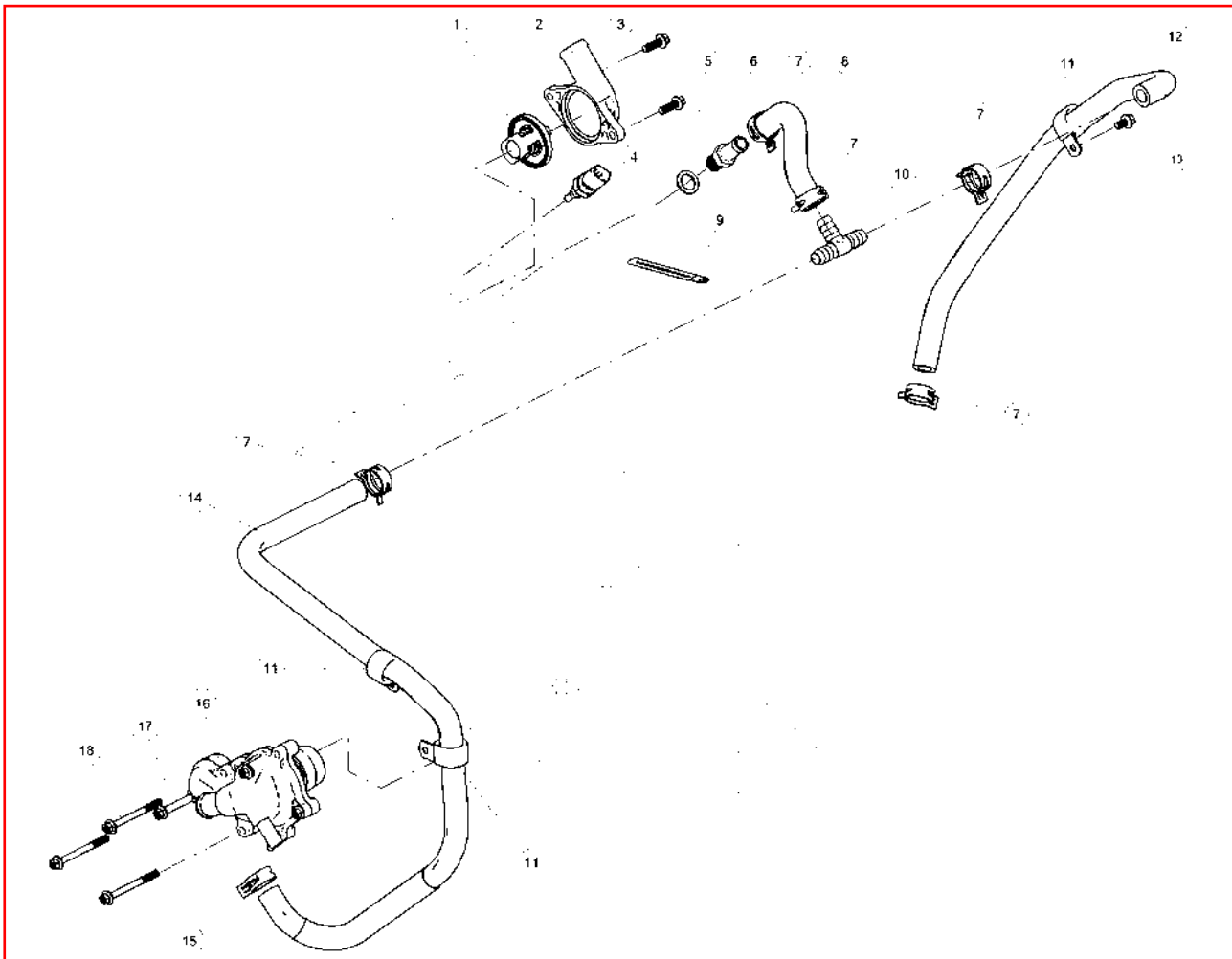
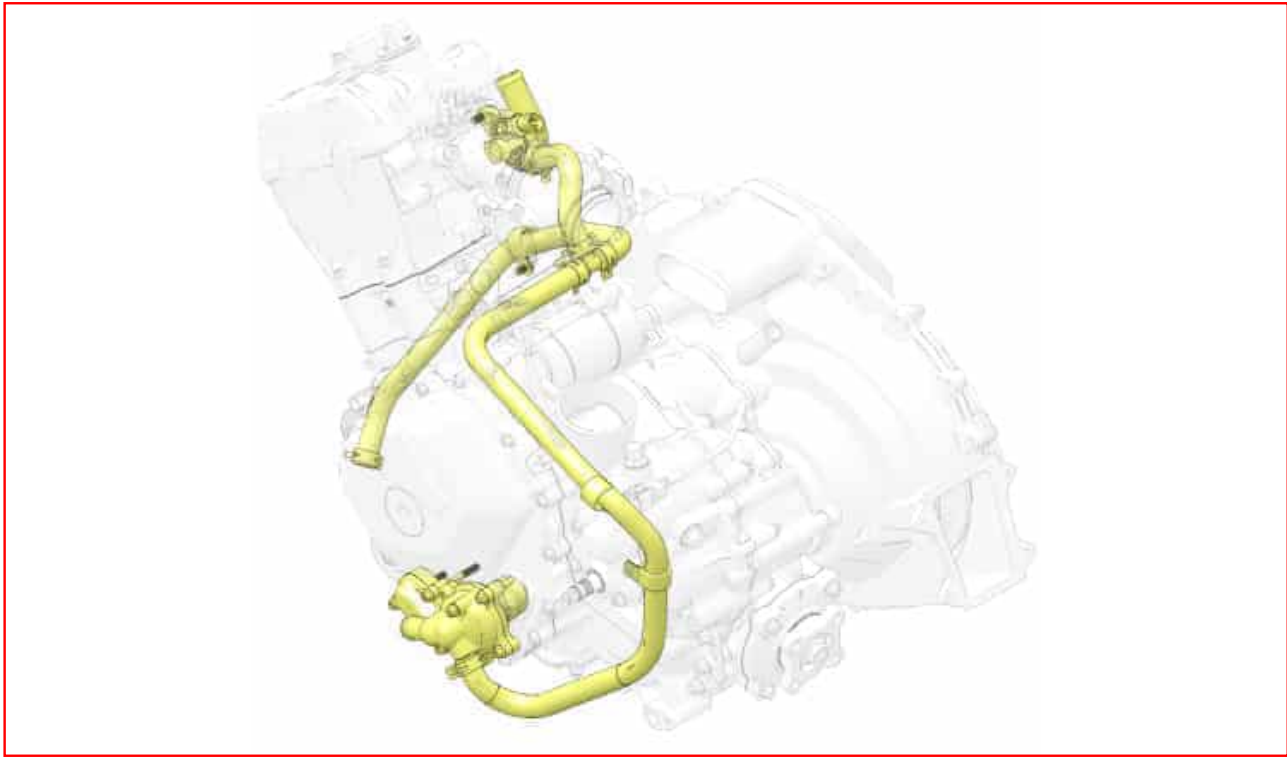

CRANKSHAFT / TRANSMISSION

SEGWAY AT5

No.	Fastener	Torque			Remarks
		N·m	kgf·m	ft·lb	
1	Thermostat assembly				
2	thermostat cover				
3	Bolt M6×20	9.8	1.0	87 in·lb	
4	Water Temperature Sensor				
5	Aluminum washer 14×21×1.5				
6	Coupling Plumbing Fittings				
7	Steel band elastic hose clamp hoop 22				
8	Water pipe 12×20×147				
9	Plastic-coated wire clips (10x95)				
10	tee				
11	hose clamp				
12	Water pipe 12×20×455				
13	Bolt M6×12	9.8	1.0	87 in·lb	
14	Small circulating water pipe assembly 12 x 20 x 798				
15	Steel band elastic hose clamping hoop 21				
16	Water Pump Components				
17	Bolt M6×35	9.8	1.0	87 in·lb	
18	Bolt M6×60	9.8	1.0	87 in·lb	

TECHNICAL PARAMETER

Item	Standard	Service Limit
Coolant provided when shipping:		
Type	Permanent type of antifreeze (soft water and ethylene glycol plus corrosion and rust inhibitor chemicals for aluminum engines and radiators)	---
Color	Green	---
Mixed ratio	Soft water 50%, coolant 50%	---
Freezing point	-35°C (-95°F)	---
Total amount	3.0 L (3.17 US qt) (reserve tank full level including radiator and engine)	---
Radiator cap:		
Relief pressure	93 ~ 123 kPa (0.95 ~ 1.25 kgf/cm ² , 14 ~ 18 psi)	---
Thermostat:		
Valve opening temperature	79±2 °C (174.2±3.6°F)	---
Valve full opening lift	8 mm or more @ 90 ± 2°C (194 ± 3.6°F)	---

WATER PUMP

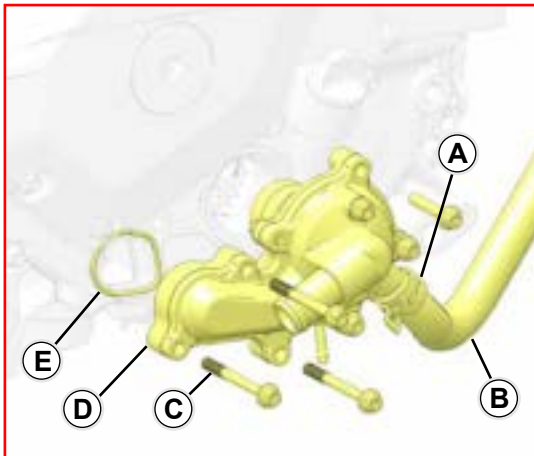

WATER PUMP REMOVAL

◆ Drain the engine coolant and oil

◆ Remove:

Clamp **【A】**

Cooling Hoses **【B】**

Water Pump Bolts **【C】**

Water Pump **【D】**

Water Pump Gasket **【E】**

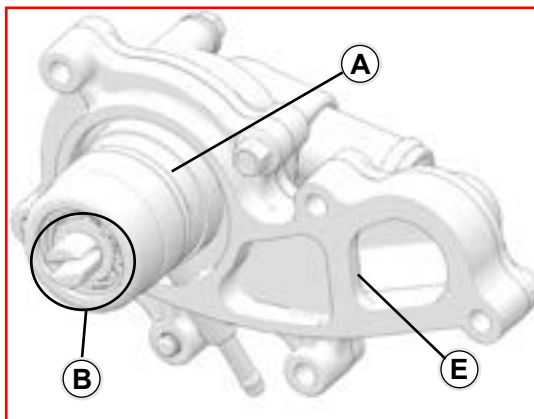

WATER PUMP INSTALLATION

◆ Apply engine oil to the Oil Pump O-ring **【A】**

◆ Install the Water Pump Gasket **【D】** to the sealing groove of the alternator cover

◆ Turn the notch **【B】** of the water pump shaft to align the convex square **【C】** side of the oil pump shaft

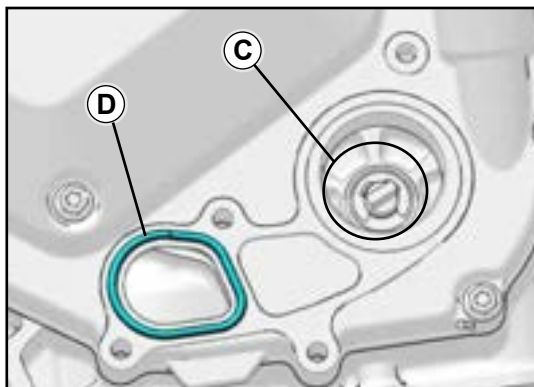

◆ Install the Water Pump **【E】** to the mounting hole of the alternator cover

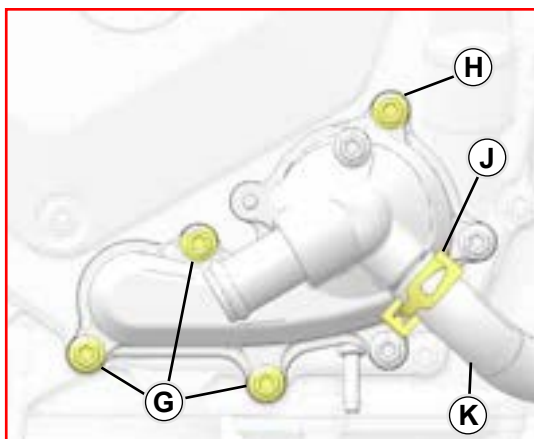

◆ Install the Water Pump Bolts:

M6×60 (3)**【G】**

M6×35 (1)**【H】**

◆ Tighten

Torque

Bolts M6
9.8 N•m (1.0kgf•m, 87 in•lb)

◆ Install Cooling Hoses **【K】**

◆ Install Clamp **【J】**

THERMOSTAT

THERMOSTAT REMOVAL

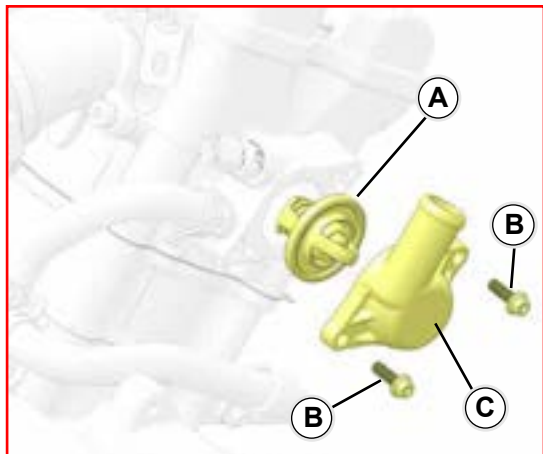

◆ Drain the coolant (see Cooling System in Periodic Maintenance chapter).

◆ Remove:

Thermostat Housing Cover Bolts **【B】**

Thermostat Housing Cover **【C】**

Thermostat **【A】**

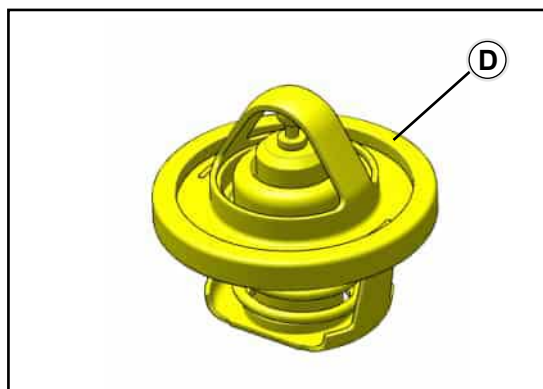

THERMOSTAT INSTALLATION

◆ Be sure to install the O-ring **【D】** on the Thermostat

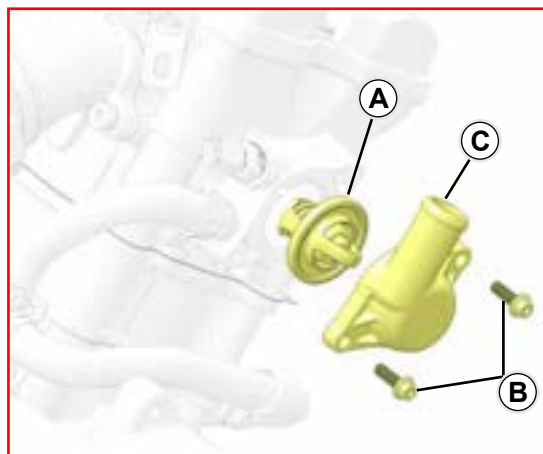

◆ Install:

Thermostat **【A】**

Thermostat Housing Cover **【C】**

Thermostat Housing Cover Bolts **【B】**

◆ Tighten:

Torque

Water Pump Cover Bolts

9.8 N•m (1.0kgf•m, 87 in•lb)

◆ Add coolant (see Cooling System in Periodic Maintenance chapter).

THERMOSTAT INSPECTION

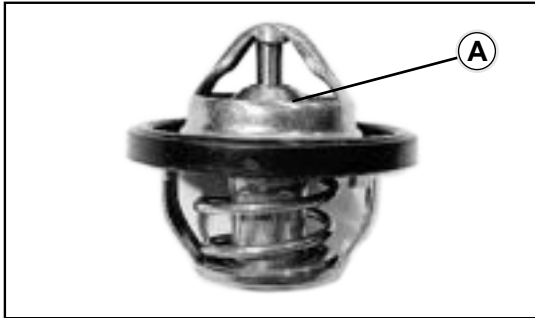

- ◆ Remove the thermostat, and inspect the thermostat valve **【A】** at room temperature.

If the valve is open, replace the valve with a new one.

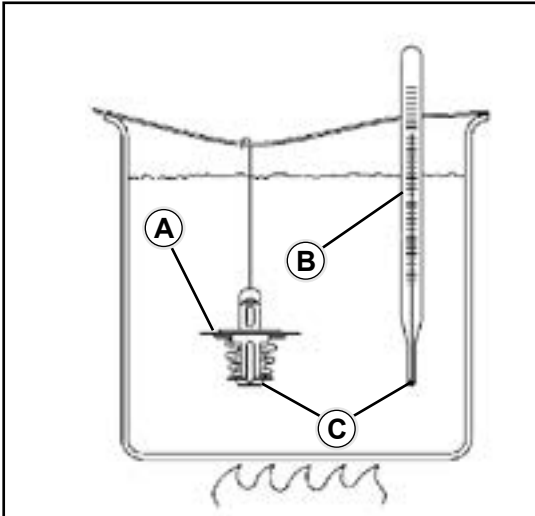

- ◆ To check valve opening temperature, suspend the thermostat **【A】** and an accurate thermometer **【B】** in a container of water with the heat-sensitive portions **【C】** in almost the same depth.

NOTE

Take care against burns from hot engine oil that will drain through the oil passage when the gauge adapter is removed.

- ◆ Gradually raise the temperature of the water while stirring the water gently for even temperature.

If the measurement is out of the range, replace the thermostat.

Thermostat Valve Opening Temperature

79±2 °C (174.2±35.6°F)

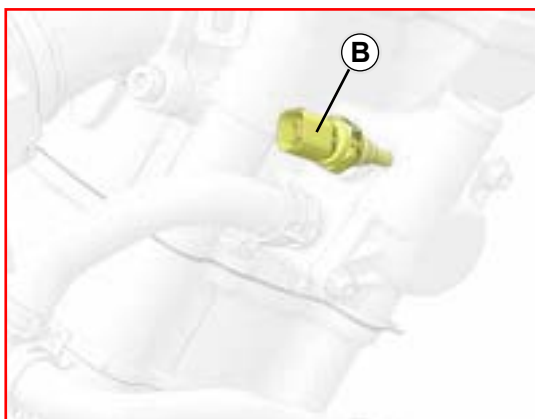
COOLANT TEMPERATURE SENSOR**COOLANT TEMPERATURE SENSOR REMOVAL****⚠ CAUTION**

The coolant temperature sensor should never be allowed to fall on a hard surface. Such a shock to the part can damage it.

- ◆ Drain the coolant (see Cooling System in Periodic Maintenance chapter).
- ◆ Disconnect the Sensor lead.
- ◆ Remove the Sensor **【B】** .

COOLANT TEMPERATURE SENSOR INSTALLATION

- ◆ Apply silicone sealant to the threads of the Sensor and tighten it
- ◆ Tighten:

Torque

Coolant Temperature Sensor
12 N•m (1.2kgf•m, 107 in•lb)

- ◆ Fill the coolant (see Cooling System in Periodic Maintenance chapter).

COOLANT TEMPERATURE SENSOR INSPECTION

- ◆ Refer to the Electrical System chapter.

ENGINE TOP END

TECHNICAL PARAMETER	3-5-6
SPECIAL TOOLS	3-5-8
SPARK PLUG / VALVE COVER / THROTTLE BODY / CAMSHAFT	3-5-9
THROTTLE BODY	3-5-10
THROTTLE BODY REMOVAL	3-5-10
THROTTLE BODY INSTALLATION	3-5-10
AIR INTAKE PIPE REMOVAL:	3-5-10
AIR INTAKE PIPE INSTALLATION:	3-5-10
FUEL INJECTOR / THERMOSTAT	3-5-11
FUEL INJECTOR REMOVAL	3-5-11
FUEL INJECTOR INSTALLATION	3-5-11
IGNITION COIL / SPARK PLUG	3-5-12
SPARK PLUG REMOVAL	3-5-12
SPARK PLUG INSTALLATION	3-5-12
VALVE COVER	3-5-13
VALVE COVER REMOVAL	3-5-13
VALVE COVER INSTALLATION:	3-5-13
CRANK POSITION SENSOR	3-5-14
CRANK POSITION SENSOR REMOVAL	3-5-14
CAMSHAFT CHAIN TENSIONER	3-5-15
CAMSHAFT CHAIN TENSIONER REMOVAL	3-5-15
CAMSHAFT CARRIER / CAMSHAFT	3-5-16
CAMSHAFT CARRIER REMOVAL	3-5-16
CAMSHAFT INSPECTION	3-5-17
AUTOMATIC COMPRESSION RELEASE	3-5-17
AUTOMATIC COMPRESSION RELEASE REMOVAL	3-5-18
AUTOMATIC COMPRESSION RELEASE INSTALLATION	3-5-18
CAMSHAFT SPROCKET INSTALLATION	3-5-18
CAMSHAFT SPROCKET INSPECTION	3-5-18
CAMSHAFT / CAMSHAFT BORE INSPECTION	3-5-19
CAM WEAR	3-5-19
CYLINDER HEAD	3-5-20
CYLINDER HEAD REMOVAL	3-5-20
CYLINDER HEAD INSPECTION	3-5-20
CYLINDER HEAD WARP	3-5-20

CYLINDER HEAD DISASSEMBLY	3-5-21
VALVE GUIDE / VALVE INSPECTION	3-5-22
COMBUSTION CHAMBER CLEANING.....	3-5-23
VALVE SEAT RECONDITIONING.....	3-5-24
VALVE SEAT INSPECTION:	3-5-24
VALVE SEAT REPAIR (VALVE LAPPING)	3-5-25
CYLINDER AND PISTON	3-5-28
CYLINDER REMOVAL	3-5-28
PISTON REMOVAL.....	3-5-28
CYLINDER, PISTON INSTALLATION.....	3-5-29
CYLINDER WEAR	3-5-30
PISTON WEAR	3-5-30
PISTON/CYLINDER CLEARANCE.....	3-5-31
PISTON RING, PISTON RING GROOVE WEAR	3-5-31
PISTON RING GROOVE WIDTH.....	3-5-31
PISTON RING THICKNESS.....	3-5-31
PISTON RING END GAP.....	3-5-32
CYLINDER HEAD INSTALLATION	3-5-33
CYLINDER HEAD INSTALLATION	3-5-33
CAMSHAFT INSTALLATION / TIMING.....	3-5-34
CAMSHAFT INSTALLATION / TIMING	3-5-34
CAMSHAFT CHAIN TENSIONER INSTALLATION	3-5-35
VALVE CLEARANCE ADJUSTMENT	3-5-36
VALVE LASH - TAPPET SELECTION.....	3-5-38
VALVE COVER INSTALLATION	3-5-39
VALVE COVER INSTALLATION	3-5-39
CYLINDER COMPRESSION MEASUREMENT	3-5-39
CYLINDER COMPRESSION	3-5-40

EXPLODED VIEW

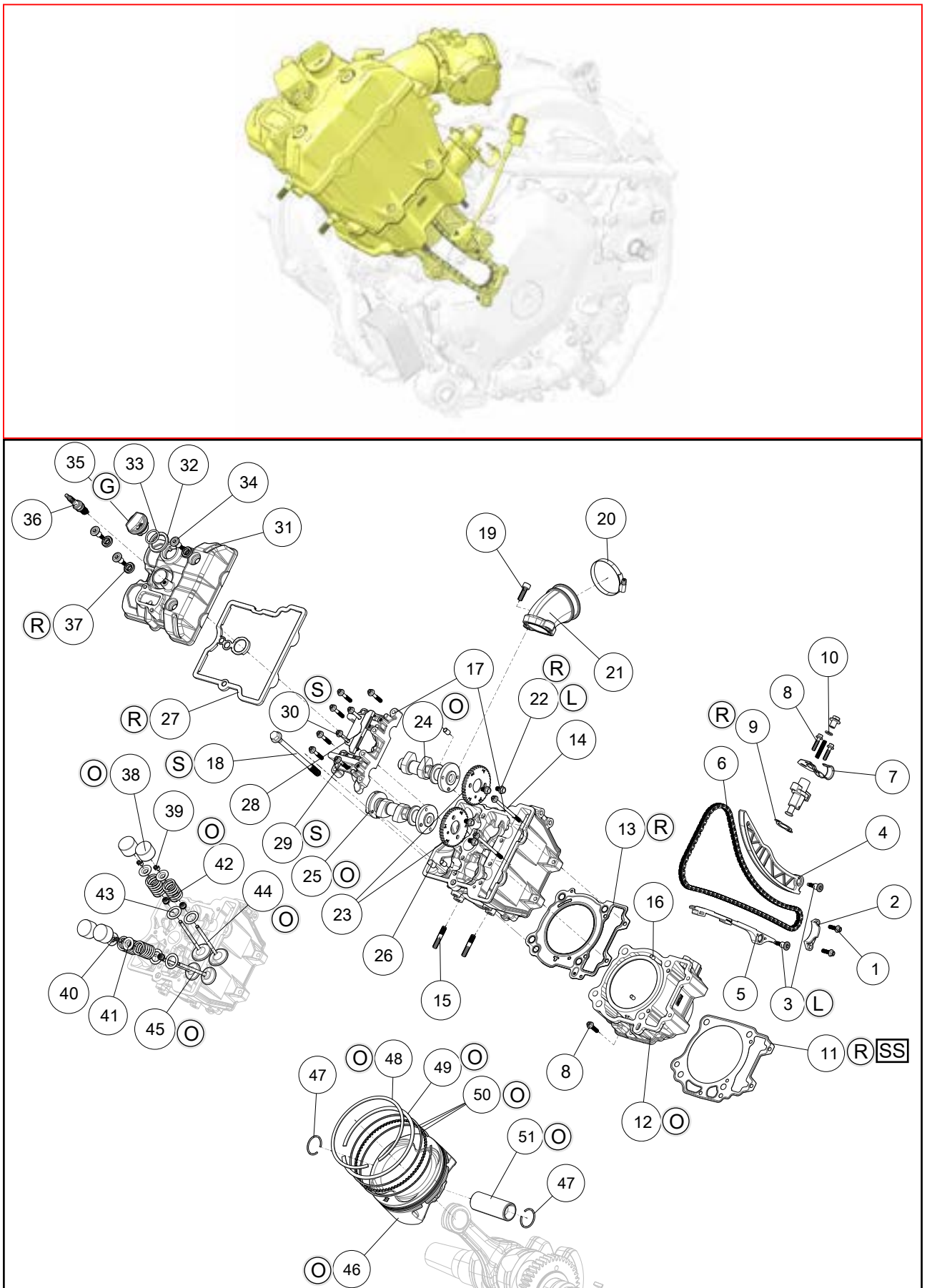

No.	Name	Torque			Remarks
		N·m	kgf·m	ft·lb	
1	Bolt M6×20	9.8	1.0	87 in·lb	
2	Chain Guard				
3	Shoulder Bolt				L
4	Chain Tensioner	9.8	1.0	87 in·lb	
5	Chain Guide Plate				
6	Timing Chain				
7	Pipe/Line Fixing Plate				
8	Bolt M6×25	9.8	1.0	87 in·lb	
9	Tensioner Gasket				R
10	Tensioner				
11	Base Gasket				R / SS
12	Cylinder				O
13	Cylinder Head Gasket				R
14	Bolt M6×90	9.8	1.0	87 in·lb	
15	Double-ended stud M8×43	20	2.0	14	
16	Dowel Pin 6×10				
17	Cylinder Head & Camshaft Carrier Combination				
18	Cylinder Head Bolt	75	7.7	54	S
19	Bolt M8×25	20	2.0	14	
20	Clamp 50 ~ 70				
21	Air Intake Pipe				
22	Bolt M6×12	9.8	1.0	87 in·lb	L / R
23	Timing Driven Sprocket				
24	Intake Camshaft Assembly				O
25	Exhaust Camshaft Assembly				O
26	Dowel Pin 10×14				
27	Valve Cover Seal				R
28	Fixed Cam Chain Guid				
29	Bolt M6×35	9.8	1.0	87 in·lb	S
30	Bolt M6×65	9.8	1.0	87 in·lb	S
31	Valve Cover				
32	Oil Fill Cap Seal				G
33	O-Ring 22×3				G
34	Shoulder Bolt	9.8	1.0	87 in·lb	
35	Oil Fill Cap				
36	Spark Plug	15	1.5	11	
37	Isolator				R

No.	Name	Torque			Remarks
		N·m	kgf·m	ft·lb	
38	Valve Bucket				O
39	Split Keeper				
40	Valve Retainer				
41	Valve Spring				
42	Valve Stem Seal				O
43	Valve Seat				
44	Intake Valve				O
45	Exhaust Valve				O
46	Piston				O
47	Piston Pin Retaining Ring				O
48	Top Ring				O
49	Second Compression Ring				O
50	Oil Ring Combination				O
51	Piston Pin				O

G: Apply grease for oil seal and O-ring.

L: Apply a non-permanent locking agent.

O: Apply engine oil.

SS: Apply silicone sealant.

S: Follow the specific tightening sequence.

R: Replacement Part.

TECHNICAL PARAMETER

Item	Standard	Service Limit
Cylinder Head:		
Cylinder compression(usable range)	450 ~700 kPa (4.7 ~ 7.2 kgf/cm ² ,65 ~ 102 psi) @ 300 r/min (rpm)	---
Electric starter	---	0.05 mm (0.002 in.)
Cylinder head warp	120.5 ± 0.03 mm (4.7441" ± 0.0012")	---
Cylinder Head Height	1.5 ~ 1.6 mm (0.0591" ~ 0.0630")	1.9 mm (0.0748")
Valve Seat Contacting Width - Exhaust	1.0 ~ 1.1 mm (0.0394" ~ 0.0433")	1.4 mm (0.0551")
Valve Seat Contacting Width - Intake	30.0° ± 1.5° / 45.0° ± 0.5° / 60.0° ± 1.5°	---
Valve Seat Angles		
Valve Guide Inner Diameter	5.500 ~ 5.512 mm (0.2165" ~ 0.2170")	---
Valve Spring:		
Valve Spring Free Length	42.5 mm (1.6732")	41.4 mm (1.6299")
Valve:		
Valve clearance (Cold):		
Exhaust	0.20 ~ 0.30 mm (0.0079" ~ 0.0117")	---
Intake	0.10 ~ 0.20 mm (0.0039" ~ 0.0079")	---
Valve head thickness:		
Exhaust	0.9 mm (0.0354")	0.5 mm (0.020")
Intake	0.7 mm (0.0276")	0.3 mm (0.012")
Valve stem bend	---	TIR 0.05 mm (0.020")
Valve stem diameter:		
Exhaust	5.455 ~ 5.470 mm (0.2147" ~ 0.2153")	
Intake	5.475 ~ 5.490 mm (0.2155" ~ 0.2161")	
Valve Stem Oil Clearance:		
Exhaust	0.030 ~ 0.060 mm (0.0011" ~ 0.0023")	
Intake	0.010 ~ 0.040 mm (0.0003" ~ 0.0015")	
Valve Stem Overall Length:		
Exhaust	96.10 mm (3.7835")	
Intake	95.50 mm (3.7598")	
Valve/valve guide clearance (wobble method):		
Exhaust	0.09 ~ 0.17 mm (0.0035" ~ 0.0067")	0.34 mm (0.0133")
Intake	0.03 ~ 0.11 mm (0.0012" ~ 0.0043")	0.25 mm (0.0110")
Piston:		
Piston O.D. :		
I	92.951 ~ 92.959 mm (3.6594" ~ 3.6597")	92.858 mm (3.6558")
II	92.959 ~ 92.967 mm (3.6597" ~ 3.66")	92.885 mm (3.6569")
Piston Pin Bore I.D.	20.009 ~ 20.018 mm(0.7877" ~ 0.7881")	20.05 mm (0.7893")

Item	Standard	Service Limit
Piston Pin: Piston Pin O.D.	20.000 ~ 20.005 mm (0.7873" ~ 0.7875")	19.98 mm (0.7866")
Piston Ring:		
Installed Gap:		0.5 mm (0.0197")
Top Ring	0.20 ~ 0.35 mm (0.0079" ~ 0.0138")	0.7 mm (0.0276")
Second Ring	0.35 ~ 0.55 mm (0.0138" ~ 0.0217")	0.9 mm (0.0354")
Oil Control Rails	0.20 ~ 0.70 mm (0.0079" ~ 0.0276")	
Ring/Groove Clearance:		0.12 mm (0.0047")
Top Ring	0.020 ~ 0.060 mm (0.0007" ~ 0.0023")	0.12 mm (0.0047")
Second Ring	0.020 ~ 0.060 mm (0.0007" ~ 0.0023")	
Piston ring groove width:		1.32 mm (0.0520")
Top Ring	1.22 ~ 1.25 mm (0.0480" ~ 0.0492")	1.32 mm (0.0520")
Second Ring	1.22 ~ 1.25 mm (0.0480" ~ 0.0492")	
Piston ring thickness:		1.10 mm (0.0433")
Top Ring	1.17 ~ 1.19 mm (0.0461" ~ 0.0469")	1.10 mm (0.0433")
Second Ring	1.17 ~ 1.19 mm (0.0461" ~ 0.0469")	
Camshafts:		
Cam Lobe height:		
Exhaust	40.08 ± 0.04 mm (1.5780" ± 0.0015")	39.99 mm (1.5744")
Intake	40.36 ± 0.04 mm (1.5890" ± 0.0015")	40.27 mm (1.5854")
Camshaft journal diameter - All:	22.954 ~ 22.975 mm (0.9036" ~ 0.9045")	22.944 mm (0.9033")
Camshaft Journal Bore diameter - All:	23.000 ~ 23.021 mm (0.9055" ~ 0.9063")	23.044 mm (0.9072")
Camshaft Oil Clearance:	0.025 ~ 0.067 mm (0.0009" ~ 0.0026")	0.1 mm (0.0039")
Camshaft End Play:	0.10 ~ 0.25 mm (0.0039" ~ 0.0098")	0.4 mm (0.0157")
Camshaft runout:	TIR ≤ 0.02 mm (0.0008")	TIR 0.1 mm (0.0039")
Connecting Rod:		
Connecting Rod Small End I.D.	20.015 ~ 20.030 mm (0.7879" ~ 0.7885")	20.06 mm (0.7897")
Main Journal O.D.	40.995 ~ 41.005 mm (1.6140" ~ 1.6144")	40.97 mm (1.6129")
Crankshaft Runout Limit	---	< 0.025 mm (0.001")
Balance Shaft:		
Bearing Journal O.D.	29.980 ~ 29.993 mm (1.1803" ~ 1.1808")	29.92 mm (1.1780")
Cylinder:		
Cylinder - Surface Warp Limit	0.05 mm (0.002")	---
Cylinder Bore - Standard:		
I	92.992 ~ 93.000 mm (3.6611" ~ 3.6614")	92.08 mm (3.6535")
II	93.000 ~ 93.008 mm (3.6614" ~ 3.6617")	93.09 mm (3.6649")
Cylinder Out of Round Limit	0.025 mm (0.001")	---
Cylinder Taper Limit	0.025 mm (0.001")	---
Cylinder/Piston Clearance	0.051 ~ 0.069 mm (0.0020" ~ 0.0027")	---

SPECIAL TOOLS

Compression Gauge



Valve Spring Compressor Assembly

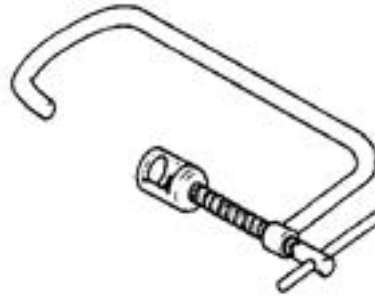

Compression Gauge Adapter, M10×1.0

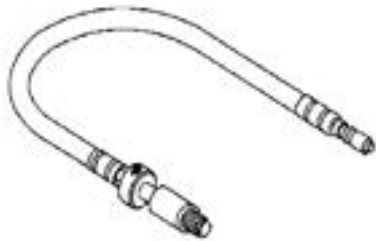

SPARK PLUG / VALVE COVER / THROTTLE BODY / CAMSHAFT

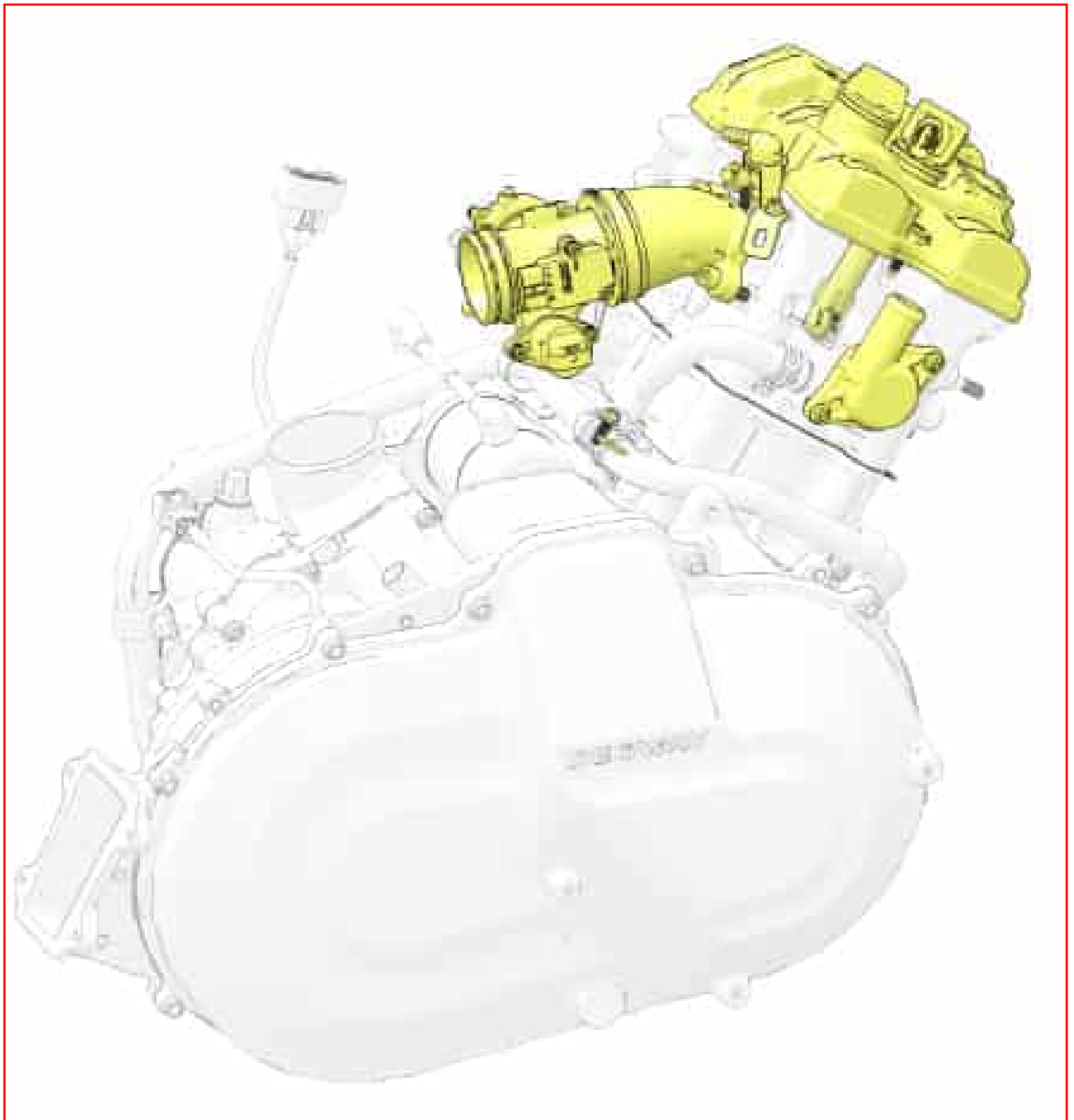

THROTTLE BODY

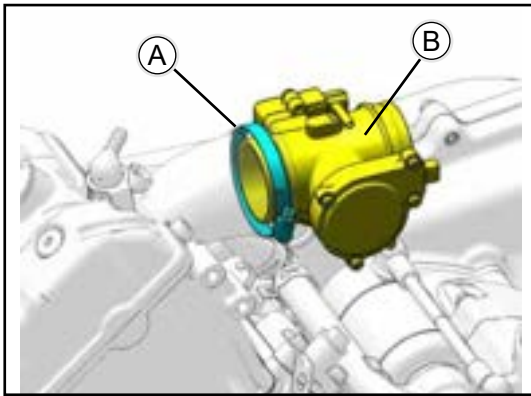

THROTTLE BODY REMOVAL

- ◆ Remove
Clamp 70 【A】
Throttle Body 【B】

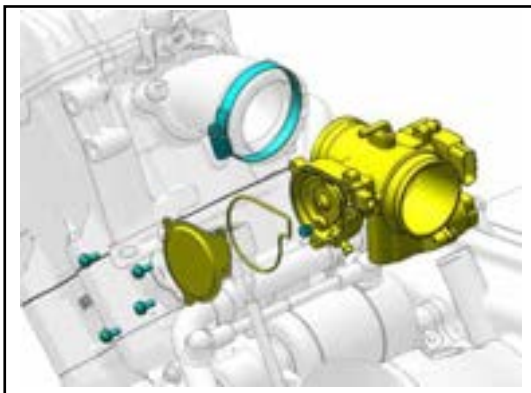

THROTTLE BODY INSTALLATION

- ◆ Install
Throttle Body
Clamp 70

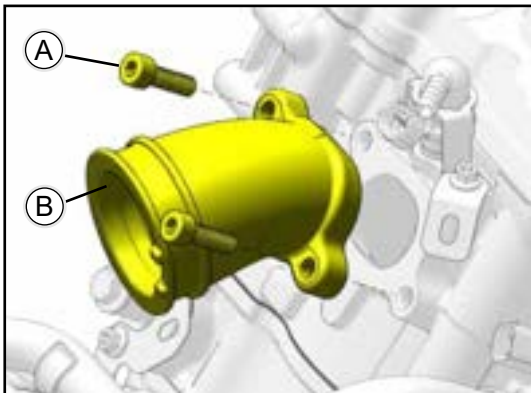

AIR INTAKE PIPE REMOVAL:

- ◆ Remove:
Bolts M8×25 【A】
Air Intake Pipe Removal 【B】

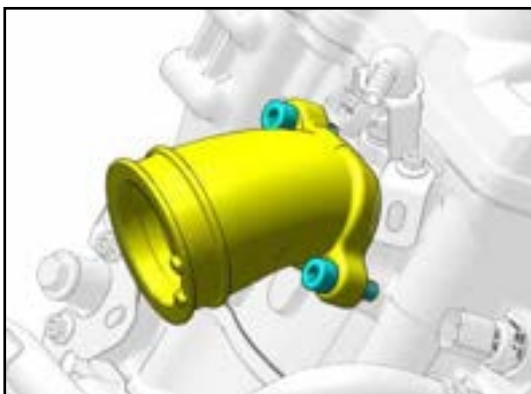

AIR INTAKE PIPE INSTALLATION:

- ◆ Install
- ◆ Tighten

Torque

Air intake Pipe Bolts

23 N•m (2.3kgf•m, 204 in•lb)

FUEL INJECTOR / THERMOSTAT

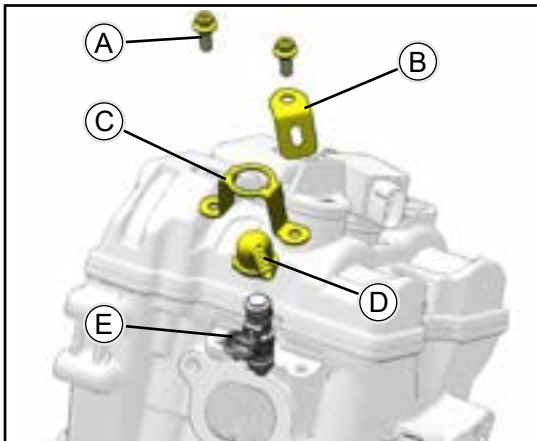

FUEL INJECTOR REMOVAL

- ◆ Disconnect the Fuel Injector Lead.
- ◆ Remove:

Fuel Injector Bolts 【A】

Fixed Plate 【B】

Fuel Injector Press Plate 【C】

Fuel Injector Adapter 【D】

Fuel Injector 【E】



FUEL INJECTOR INSTALLATION

Fuel Injector 【E】

Fuel Injector Adapter 【D】

Fuel Injector Press Plate 【C】

Fixed Plate 【B】

Fuel Injector Bolts 【A】

- ◆ Tighten

Torque

Fuel Injector Bolts
9.8 N•m (1.0kgf•m, 87 in•lb)



- ◆ Thermostat Removal and Install(See Cooling System)

IGNITION COIL / SPARK PLUG

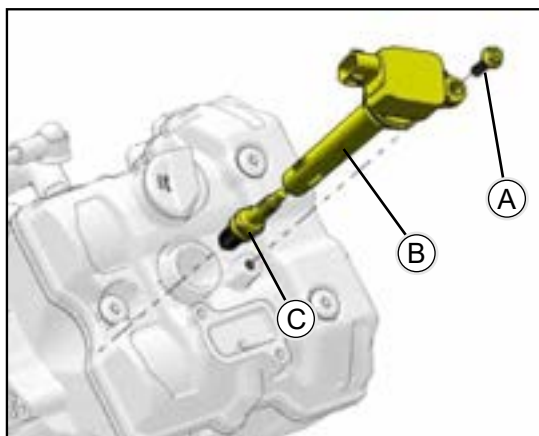

SPARK PLUG REMOVAL

- ◆ Disconnect the Ignition Coil Lead.
- ◆ Remove:

Bolt M6×20 **【A】**

Ignition Coil **【B】**

Spark Plug **【C】**

⚠ CAUTION

The Spark Plug should never be allowed to fall on a hard surface. Such a shock to the part can damage it.

NOTE

Remove the spark plug. Stuff spark plug holes with shop towels to prevent anything from falling into the combustion chamber.

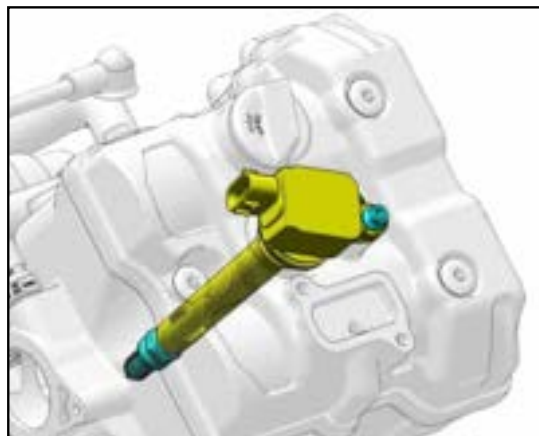

SPARK PLUG INSTALLATION

- ◆ Apply anti-seize compound to spark plug threads.
- ◆ Install

Spark Plug

Ignition Coil

Bolt M6×20

- ◆ Tighten

Torque

Bolt M6×20

10 N•m (1.0kgf•m, 87in•lb)

Spark Plug

15 N•m (1.5 kgf•m, 11 ft•lb)



Spark Plug Inspection :

Spark Plug electrode gap : **【H】** =0.7 ~ 0.9

VALVE COVER

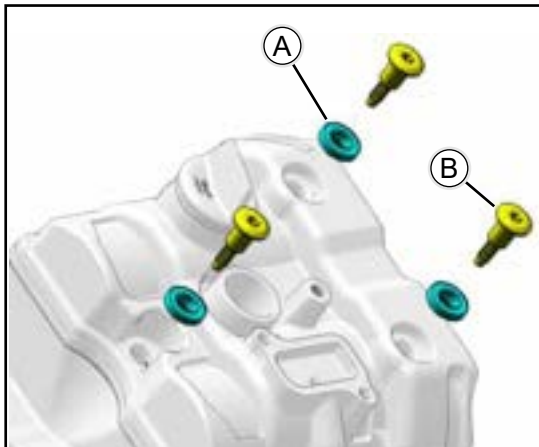

VALVE COVER REMOVAL

- ◆ Remove:
 - Shoulder Bolts 【B】 (using a T40 driver)
 - Isolators 【A】
 - Valve Cover 【C】
 - Valve Cover Seal 【D】
 - Dowel Pin 10×14 【E】

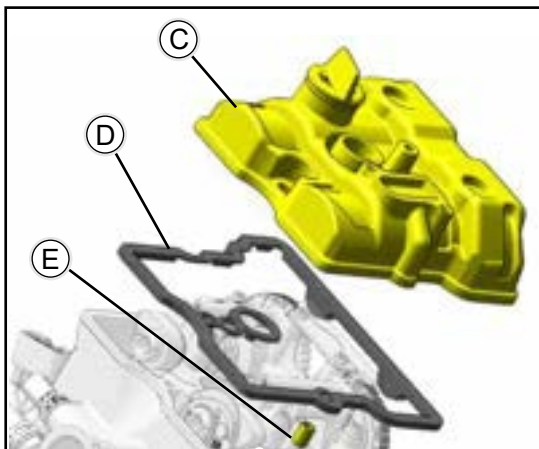

VALVE COVER INSTALLATION:

- ◆ Replace isolators 【B】 and valve cover seal 【C】 if oil leaks are evident.
- ◆ Prepare valve cover sealing surfaces by cleaning thoroughly to remove all residue.
- ◆ Install
 - Dowel Pin 10×14 【E】
 - Valve Cover Seal 【D】
 - Valve Cover 【C】
 - isolators 【A】
 - Shoulder Bolts 【B】 (using a T40 driver)

- ◆ Tighten

Torque

Shoulder Bolts
9.8 N•m (1.0kgf•m, 87in•lb)

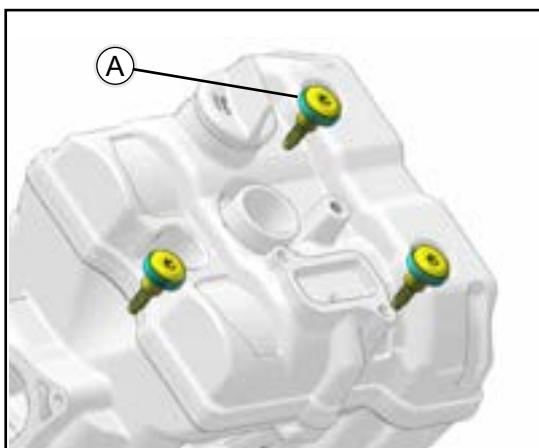

CRANK POSITION SENSOR

CRANK POSITION SENSOR REMOVAL

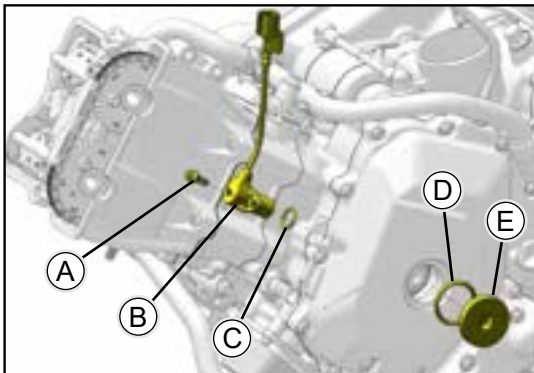

- ◆ Disconnect the Crank Position Sensor Lead.

- ◆ Remove:

Bolt M6×16 **【A】**
 Crank Position Sensor **【B】**
 O-Ring 17×2 **【C】**

- ◆ Remove:

Stator Cover Plug **【E】**
 O-Ring 35×3.5 **【D】**

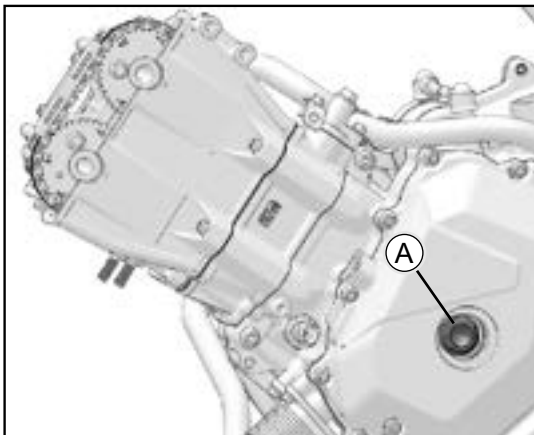

- ◆ Using a wrench on the alternator Nut **【A】**, Rotate counterclockwise the crankshaft until the flywheel TDC mark **【B】** is aligned or centered in the Crankshaft Position Sensor (CPS) mounting hole to relieve most of the valve spring pressure. The camshaft lobes should face out and the slots on the end of the camshafts should line up.

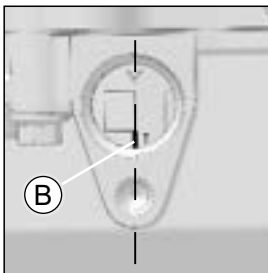

⚠ CAUTION

Be sure to position the crankshaft at TDC of the end of the compression stroke when removing or installing the camshaft carrier. The camshaft could bend the valves.

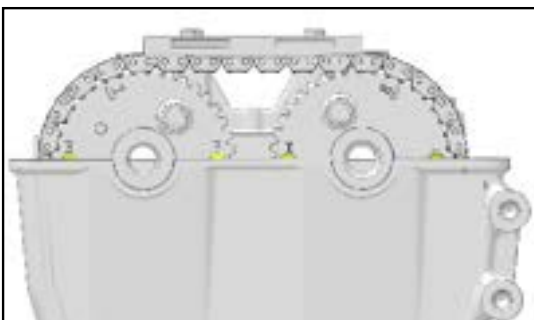
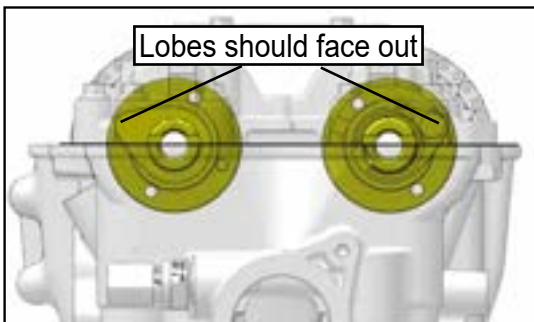

CAMSHAFT CHAIN TENSIONER

CAMSHAFT CHAIN TENSIONER REMOVAL

⚠ CAUTION

This is a non-return type cam chain tensioner. The push rod does not return to its original position once it moves out to take up cam chain slack. Observe all the rules listed below:

When removing the tensioner, do not take out the mounting bolts only partway. Retightening the mounting bolts from this position could damage the tensioner and the camshaft chain. Once the bolts are loosened, the tensioner must be removed and reset as described in "Camshaft Chain Tensioner Installation".

Do not turn over the crankshaft while the tensioner is removed. This could upset the cam chain timing, and damage the valves.

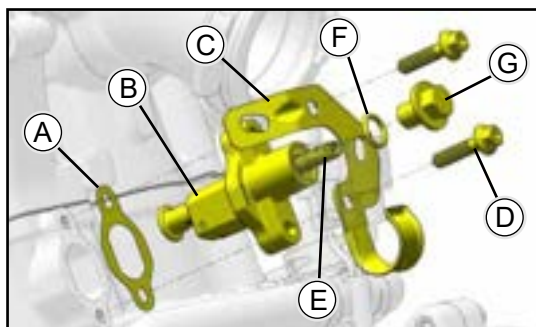
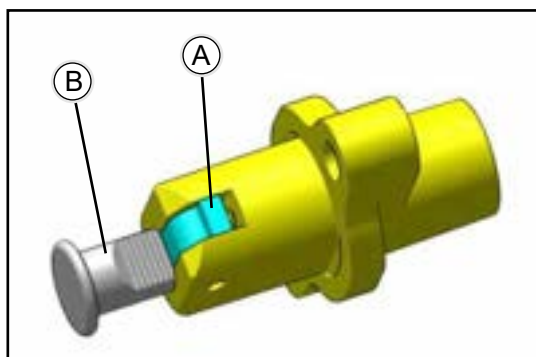
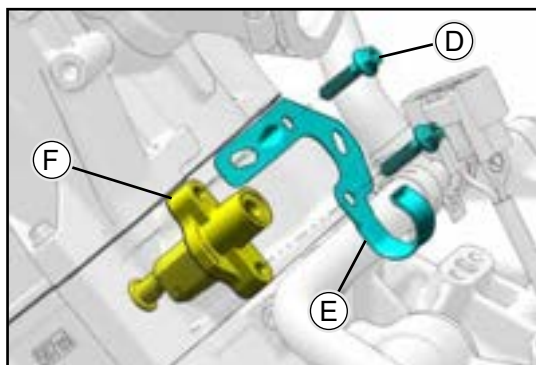
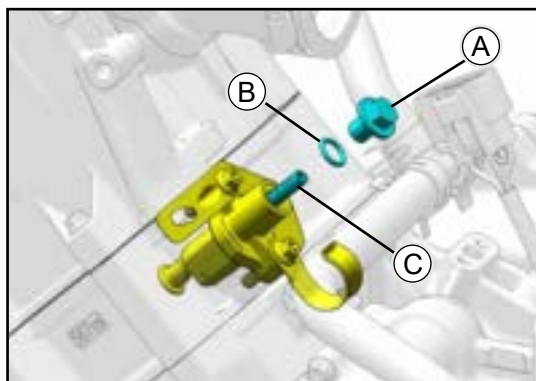

◆ Remove:

Tensioner Cap Bolt **【A】** and O-Ring **【B】**

Spring **【C】**

Tensioner Mounting Bolts **【D】**

Pipe/line Fixing Plate **【E】**

Camshaft Chain Tensioner **【F】**

Camshaft Chain Tensioner Installation

◆ Push the stopper **【A】** to release the ratchet and push the push rod **【B】** into the tensioner body.

◆ Install

Replace the New Tensioner Gasket **【A】**

Tensioner **【B】**

Pipe/line Fixing Plate **【C】** and Mounting Bolts **【D】**

Spring **【E】**, O-Ring **【F】** and Tensioner Cap Bolt **【G】**

◆ Tighten:

Torque

Chain Tensioner Mounting Bolts

9.8 N•m (1.0 kgf•m, 87 in•lb)

Chain Tensioner Cap Bolt

12 N•m(1.2 kgf•m, 8.8 ft•lb)

CAMSHAFT CARRIER / CAMSHAFT

CAMSHAFT CARRIER REMOVAL

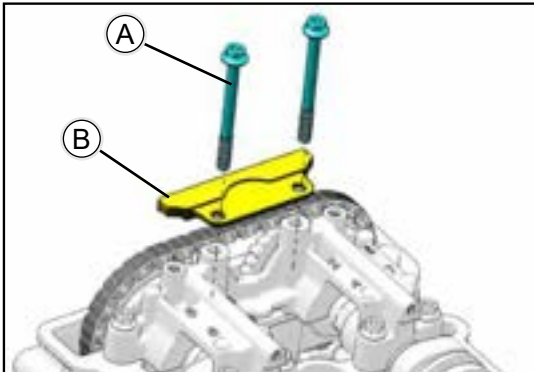

- ◆ Remove the bolts M6×65 **【A】** retaining the fixed cam chain guide **【B】** and remove the assembly from the engine.

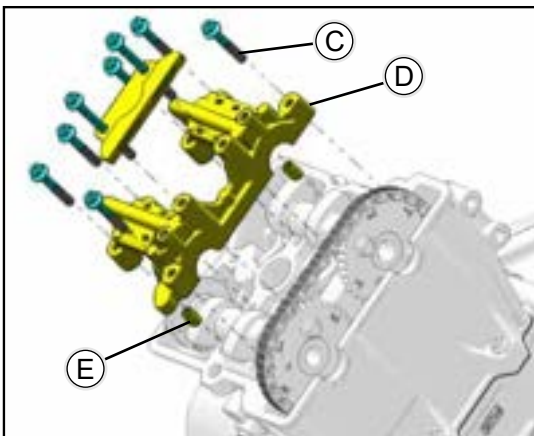

- ◆ Remove
Bolts M6×35 **【C】**
Camshaft Carrier **【D】**
Dowel Pin 8×14 **【E】**

NOTE

Evenly loosen the bolts retaining camshaft carrier carefully lift the camshaft carrier off the camshafts.

- ◆ Lift the chain off the camshafts to allow each Camshaft to be removed.

NOTE

Carefully remove camshafts from the cylinder head

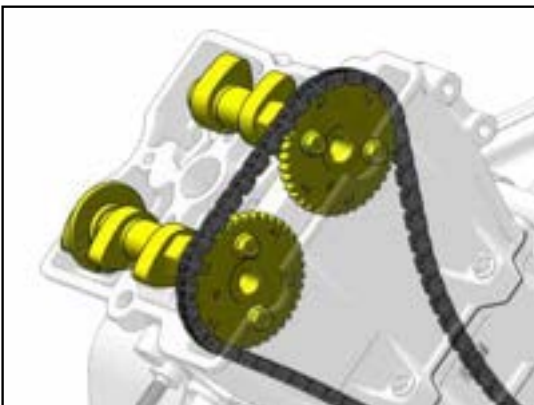

- ◆ Use a hook or similar tool to hold the timing chain up to prevent the chain from falling into the engine.

NOTE

The crankcase has a built-in lower guide to prevent the chain from falling off the crankshaft.

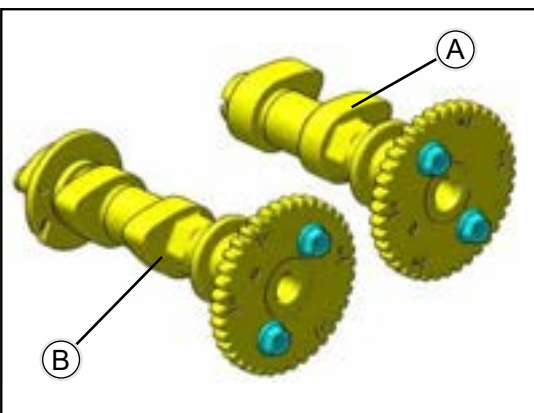

- ◆ Mark the intake **【A】** and exhaust **【B】** camshafts to ensure proper assembly.

CAMSHAFT INSPECTION

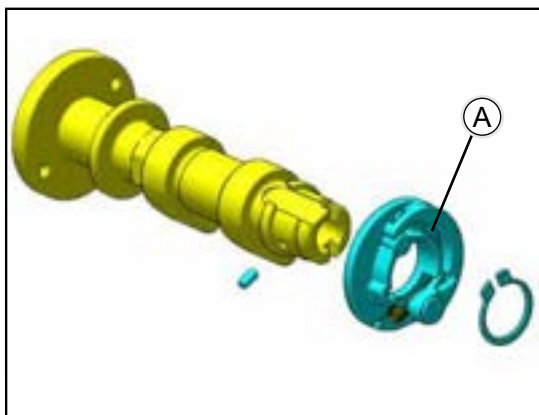
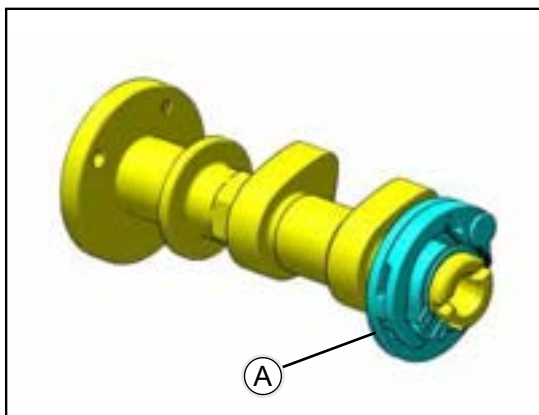

AUTOMATIC COMPRESSION RELEASE

The Automatic Compression Release momentarily opens the exhaust valves on the compression stroke at very low speeds. This allows some of the compression pressure to escape, making it easy to turn over the engine during starting.

Due to the simplicity of the mechanism, no periodic maintenance is needed. There are only two symptoms of problems with the Automatic Compression Release mechanism **【A】** : compression is not released during starting, and compression is released during running.

(1) If compression is not released during starting, the Weight Block are not returning to their rest position.

- ◆ Remove the camshaft (see Camshaft Removal).
- ◆ Remove the Automatic Compression Release unit.
- ◆ Visually inspect the spring.

If damaged, deformed, or missing, replace the spring.

- ◆ Remove the spring and move the Weight Block back and forth.

If the Weight Block do not move smoothly, replace the Automatic Compression Release unit. Also inspect the exhaust camshaft for any damage, and replace the exhaust camshaft if necessary.

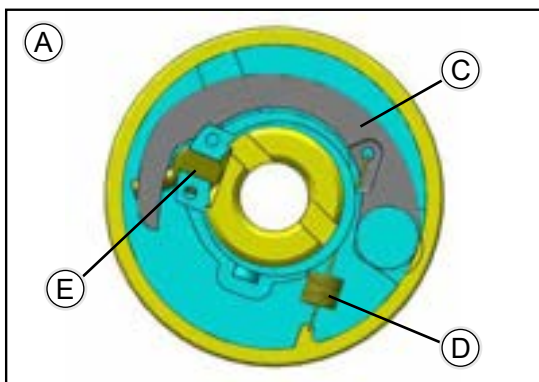

【B】 Rest Position (compression is released)

【C】 Weight Block

【D】 Spring

【E】 Compression Release Pin

(2) If compression is released while the engine is running, the Weight Block are not swinging out.

- ◆ Remove the spring and move the Weight Block back and forth.

(3) If the Weight Block do not move easily from the retracted position, replace the Automatic Compression Release unit. Also inspect the exhaust camshaft for any damage, and replace the exhaust camshaft if necessary.

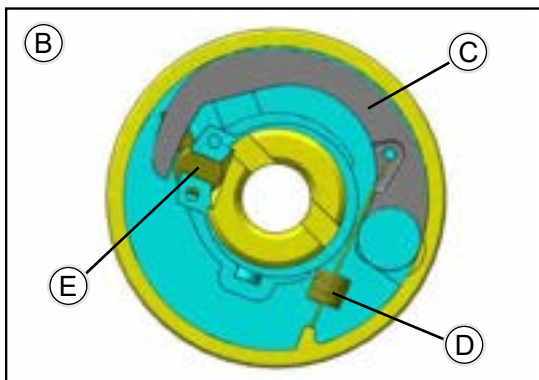

【B】 Running Position (compression is not released)

【C】 Weight Block

【D】 Spring

【E】 Compression Release Pin

AUTOMATIC COMPRESSION RELEASE REMOVAL

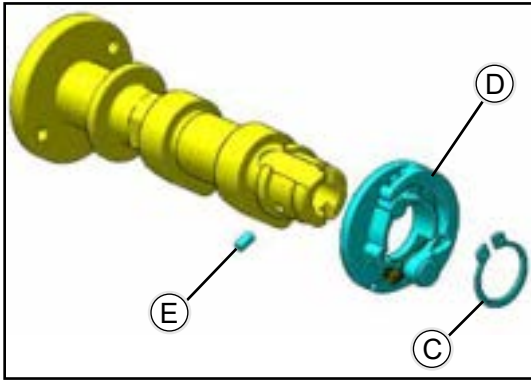

- ◆ Remove:
- Camshaft (see Camshaft Removal)
- Circlip **【C】**
- Automatic Compression Release Unit **【D】**
- Dowel Pin **【E】**

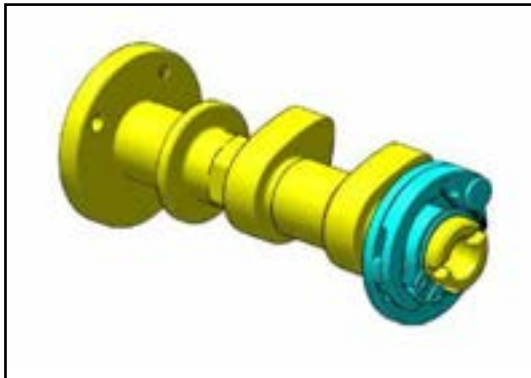

AUTOMATIC COMPRESSION RELEASE INSTALLATION

- ◆ Install:
- Dowel Pin **【E】**
- Automatic Compression Release Unit **【D】**
- Circlip **【C】**

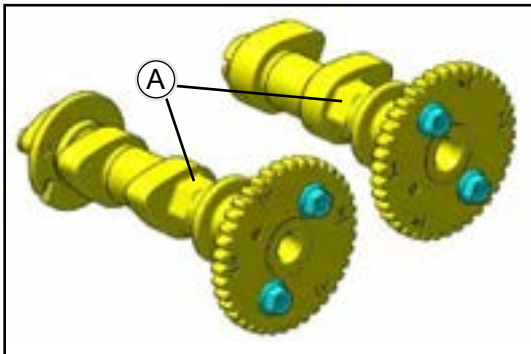

CAMSHAFT SPROCKET INSTALLATION

- ◆ Install the sprockets on the intake and exhaust camshafts.
- ◆ Fix the hexagonal surface **【A】** of the Camshaft with tools, and tighten the sprocket bolts.
- ◆ Apply a non-permanent locking agent to the bolts.

Torque

Sprocket bolts
18 N•m (1.8 kgf•m, 13.3 ft•lb)

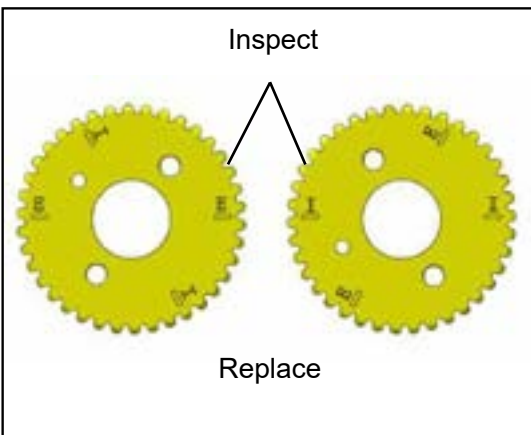

CAMSHAFT SPROCKET INSPECTION

- ◆ Inspect cam sprocket teeth for wear or damage. Replace timing chain and sprockets if worn or damaged.

CAMSHAFT / CAMSHAFT BORE INSPECTION

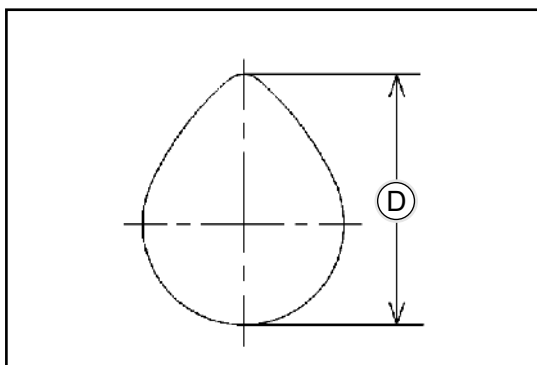

CAM WEAR

- ◆ Visually inspect each cam lobe for wear or damage.
- ◆ Measure the height **【D】** of the cam with a micrometer.

If the cams are worn past the service limit, replace the camshaft.

Camshaft Lobe Height:

	Standard	Service Limit
Exhaust	40.08 ± 0.04 mm (1.5780" ± 0.0015")	39.99 mm (1.5744")
Inlet	40.36 ± 0.04 mm (1.5890" ± 0.0015")	40.27 mm (1.5854")

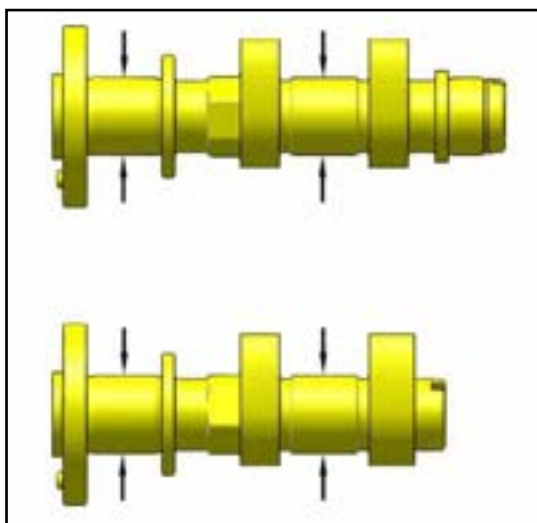

- ◆ Visually inspect each camshaft journal for scoring, wear or damage.
- ◆ Measure the diameter of the camshaft journals using a micrometer. Compare to specification.
- ◆ Replace camshafts if damaged or if any part is worn past the service limit.

Standard	Service Limit
22.954 ~ 22.975 mm(0.9036" ~ 0.9045")	22.944 mm (0.9033")

- ◆ Temporarily install the camshaft carriers to measure the camshaft bore. Torque bolts in sequence to specification. Replace cylinder head if worn.

Torque

Camshaft Carrier Bolts
10 N•m (1.0 kgf•m, 89 in•lb)

- ◆ Replace cylinder head if camshaft journal bores are damaged or if worn past the service limit.

Standard	Service Limit
23.000 ~ 23.021 mm(0.9055" ~ 0.9063")	23.044 mm (0.9072")

- ◆ Calculate oil clearance by subtracting camshaft journal O.D.s from camshaft carrier bore I.D.s. Compare to specification.

Standard	Service Limit
0.025~ 0.067 mm (0.0009" ~ 0.0026")	0.10 mm (0.0039")

⚠ CAUTION

The cylinder head and Camshaft Carrier are machined as a set, and must be replaced as a set.

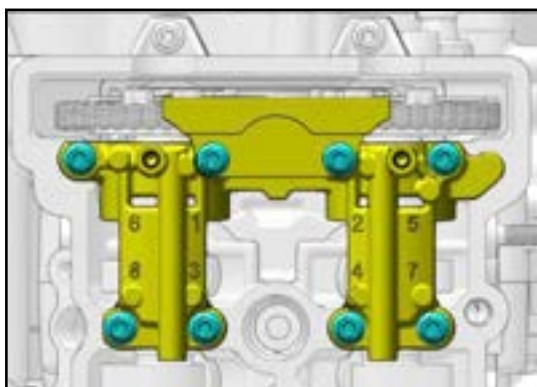

CYLINDER HEAD

CYLINDER HEAD REMOVAL

NOTE

The cylinder head can be serviced with the engine installed in the chassis.

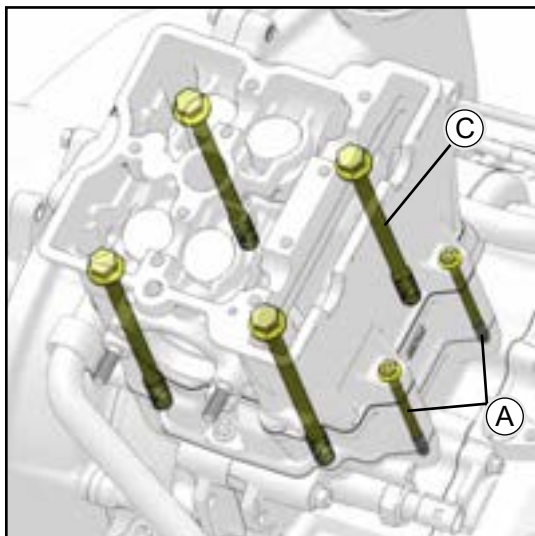

- ◆ Remove the (2) outer M6 bolts **【A】** that retain the cylinder head **【B】** to the cylinder.
- ◆ Loosen the (4) cylinder head bolts **【C】** evenly 1/8 turn at a time until all are loose.
- ◆ Remove and discard the cylinder head bolts **【C】**.
- ◆ Tap cylinder head lightly with a soft faced hammer until loose.
- ◆ Tap only in reinforced areas or on thick parts of the cylinder head casting.
- ◆ Remove the cylinder head **【B】** and head gasket **【D】**.

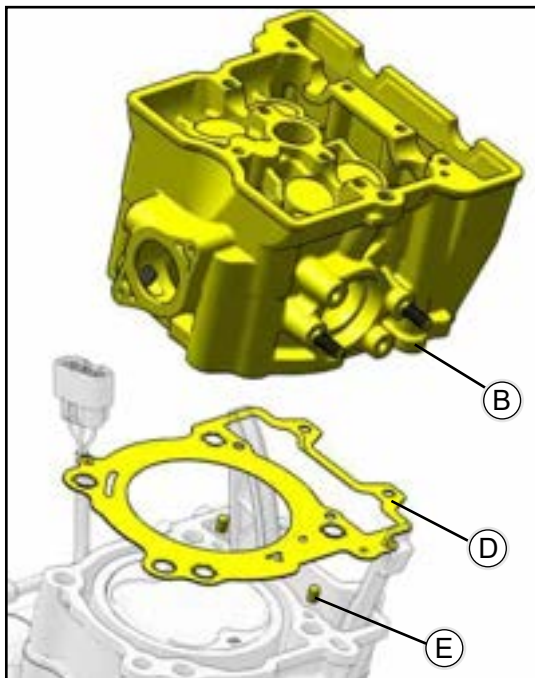

CYLINDER HEAD INSPECTION

- ◆ Thoroughly clean cylinder head surface to remove all traces of gasket material and carbon.

CAUTION

Use care not to damage gasket sealing surface. All gasket surfaces must be clean, dry and free of any oil or grease upon assembly. Clean sealing surfaces with rubbing alcohol or electrical contact cleaner. Do not touch sealing surfaces of the new head gasket.

CYLINDER HEAD WARP

- ◆ Clean the cylinder head.
- ◆ Lay a straightedge across the lower surface of the cylinder head.
- ◆ Use a thickness gauge to measure the space between the straightedge **【F】** and the head at several locations.

Cylinder Head Warp Limit : 0.05 mm (0.002")

If the cylinder head is warped more than the service limit, replace it.

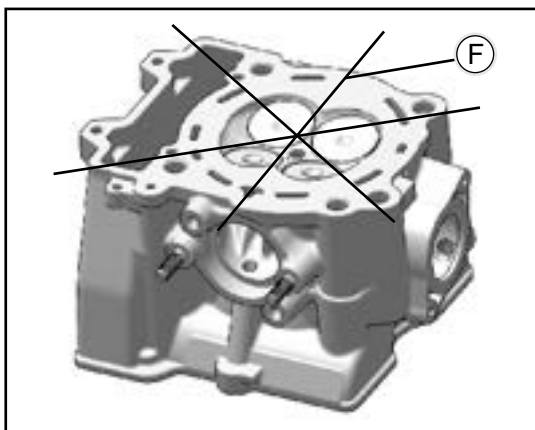

CYLINDER HEAD DISASSEMBLY

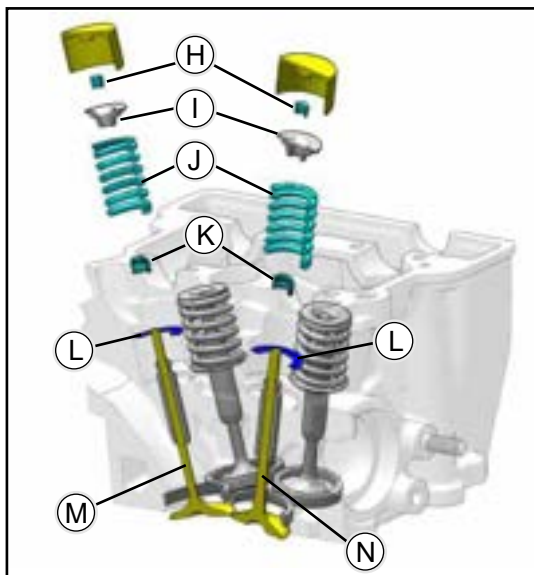
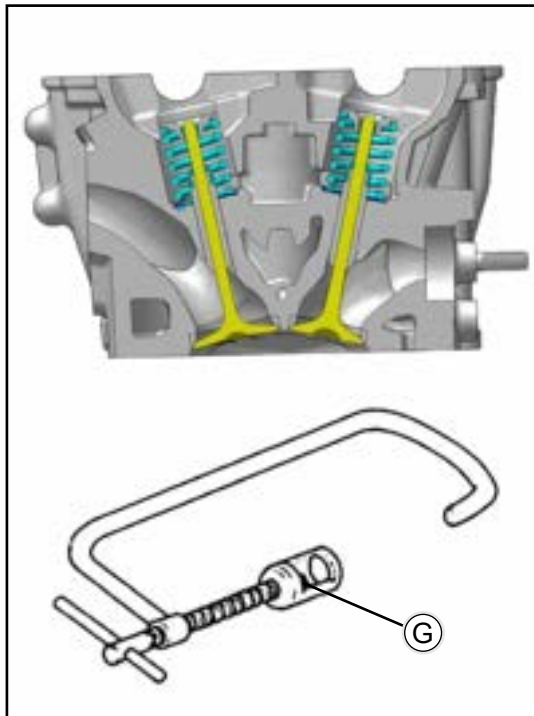
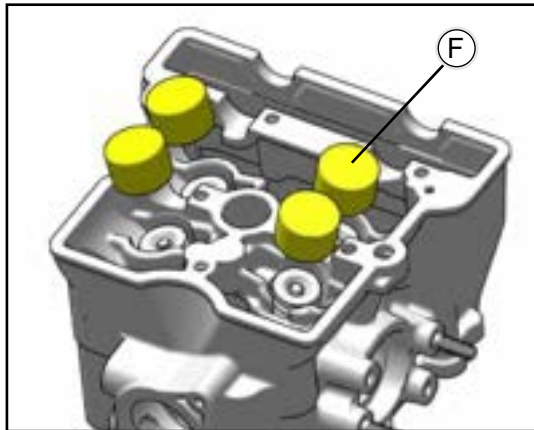
**⚠ WARNING**

Wear eye protection during cylinder head disassembly and reassembly or when working with the valve springs.

IMPORTANT

Keep mated parts together and in order with respect to their location in the cylinder head for assembly purposes. It is important to install cylinder head components back in the same location. Mark each component or place them in an organized rack as you remove them.

- ◆ Remove the valve bucket **【F】** from the cylinder head.
- ◆ Compress the valve spring by hand using valve spring compressor adapter **【G】**.
- ◆ Push down on spring and remove split keepers **【H】**
- ◆ Slowly release valve spring pressure and remove the compressor adapter.
- ◆ Remove the valve retainer **【I】**, valve spring **【J】**, valve stem seal **【K】** and valve spring seat **【L】**. Discard the valve seal.

NOTE

Replace valve seals whenever cylinder head is disassembled. Hardened, cracked or worn seals will cause excessive oil consumption.

- ◆ Lift up the cylinder head and push the valve **【M】** out, keeping it in order for reassembly in the same valve guide.
- ◆ Repeat the previous steps to remove the remaining valves.
- ◆ Clean the combustion chamber and head gasket surface.

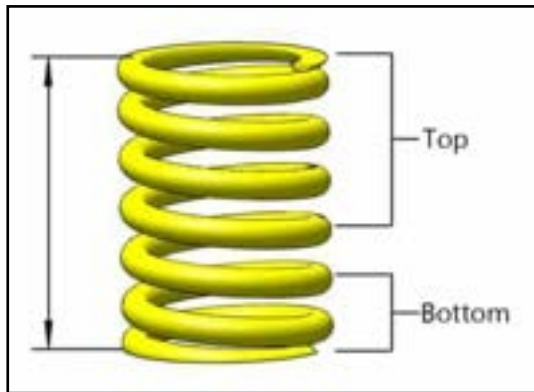

- ◆ Measure the free length of each valve spring with a Vernier caliper and compare to specification.
- ◆ Valve Spring Free Length: Standard: 1.726" (43.85 mm) Service Limit: 1.683" (42.75 mm)

Standard	Service Limit
42.5 mm (1.6732")	41.4mm (1.6299")

VALVE GUIDE / VALVE INSPECTION

- ◆ Valve-to-Guide Clearance Measurement:

If a small bore gauge is not available, inspect the valve guide wear by measuring the valve to valve guide clearance with the wobble method as indicated below.

- ◆ Insert a new valve **【A】** into the guide **【B】** and set a dial gauge against the stem perpendicular to it as close as possible to the cylinder head mating surface.
- ◆ Move **【C】** the stem back and forth to measure valve/valve guide clearance.
- ◆ Repeat the measurement in a direction at a right angle to the first.

If the reading exceeds the service limit, replace the Cylinder head & Camshaft Carrier Combination.

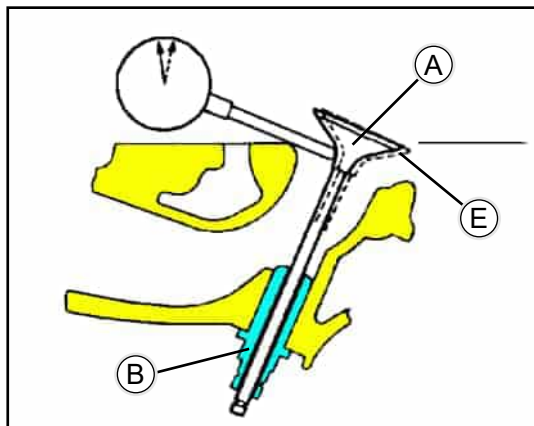

NOTE

The reading is not actual valve/valve guide clearance because the measuring point is above the guide.

Valve/Valve Guide Clearance (Wobble Method)		
	Standard	Service Limit
Exhaust:	0.09 ~ 0.17 mm (0.0035" ~ 0.0067")	0.34 mm 0.0133"
Inlet:	0.03 ~ 0.11 mm (0.0012" ~ 0.0043")	0.28 mm 0.0110"

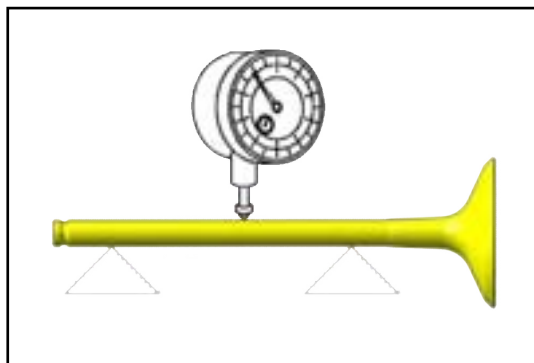

- ◆ Check valve face for runout, pitting, and burnt spots. To check for bent valve stems, mount valve in a drill or use "V" blocks and a dial indicator.
- ◆ Check the end of the valve stem for flaring, pitting, wear or damage.
- ◆ Inspect split keeper groove for wear or flaring in the keeper seat area.

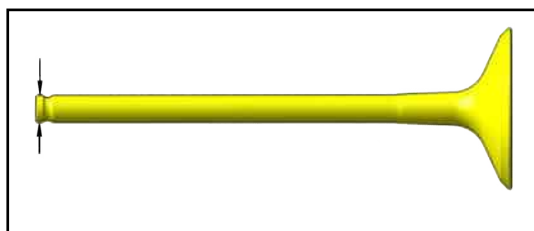

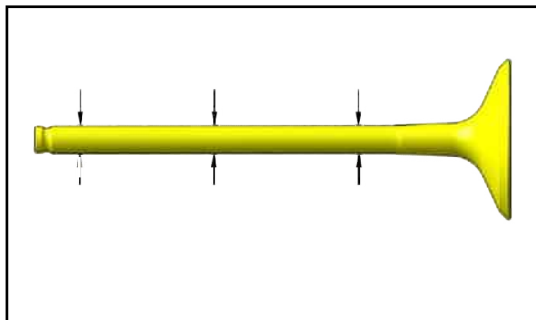

NOTE

The valves can be re-faced or end ground, if necessary. They must be replaced if extensively worn, burnt, bent or damaged.

- ◆ Measure diameter of valve stem with a micrometer in three places, then rotate 90° and measure again (take six measurements total). Compare to specifications.

Valve Stem Diameter:		
	Standard	Service Limit
Exhaust:	5.455 ~ 5.470 mm (0.2147" ~ 0.2153")	-----
Inlet:	5.475 ~ 5.490 mm (0.2155" ~ 0.2161")	-----

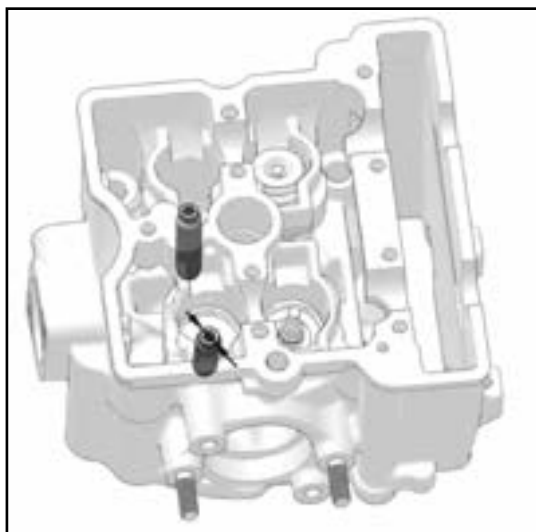

- ◆ Measure diameter of valve stem with a micrometer in three places, then rotate 90° and measure again (take six measurements total). Compare to specifications.

Valve Guide I.D.:	
5.500 - 5.515 mm (0.2165" ~ 0.2171")	

- ◆ Be sure to measure each guide and valve combination individually.

NOTE

The valve guides cannot be replaced.

COMBUSTION CHAMBER CLEANING

⚠ WARNING

Wear eye protection during combustion chamber cleaning.

- ◆ Clean all accumulated carbon deposits from combustion chambers and valve seat area.

NOTE

Carbon Clean Fuel Treatment can be used to help remove carbon deposits.

⚠ CAUTION

Do not use a metal scraper, a coarse wire brush or abrasive cleaners to clean the cylinder head. Damage may result.

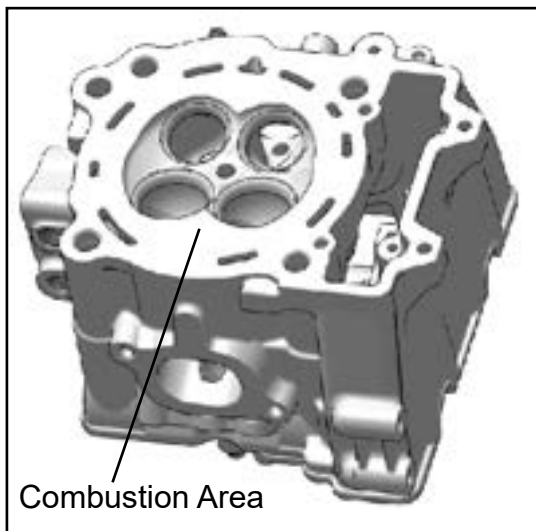

VALVE SEAT RECONDITIONING

- ◆ Valve seat reconditioning should be performed by a technician proficient in cylinder head reconditioning techniques. Reconditioning techniques vary, so follow the instructions provided by the valve reconditioning equipment manufacturer. Do not grind seats more than necessary to provide proper seat surface, width, and contact point on valve face.

⚠ WARNING

Wear eye protection or a face shield during cylinder head disassembly and reassembly.

VALVE SEAT INSPECTION:

- ◆ Remove the valve (see Valve Removal).
- ◆ Check the valve seating surface **【A】** between the valve **【B】** and valve seat **【C】**.

Coat the valve seat with machinist's dye.

Push the valve into the guide.

Rotate the valve against the seat with a lapping tool.

Pull the valve out, and check the seating pattern on the valve head. It must be the correct width and even all the way around.

- ◆ Measure the outside diameter **【D】** of the seating pattern on the valve seat.

If the outside diameter of the valve seating pattern is too large or too small, repair the seat (see Valve Seat Repair).

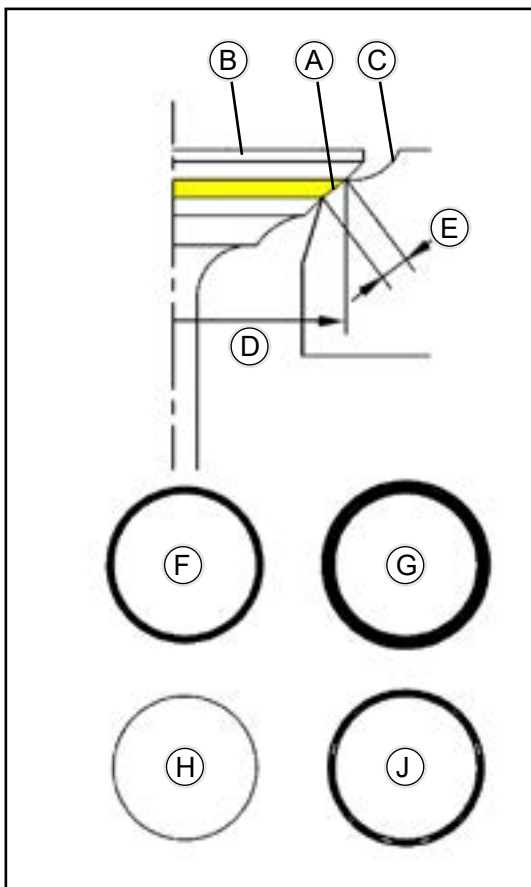

- 【F】** Good
- 【G】** Too Wide
- 【H】** Too Narrow
- 【J】** Uneven

Valve Seating Surface Width	
Exhaust:	1.5 ~ 1.6mm (0.0591" ~ 0.0630")
Inlet:	1.0 ~ 1.1mm (0.0394" ~ 0.0433")

Valve Seating Surface Outside Diameter:	
Exhaust:	31.8 ~ 31.9 mm (1.2520" ~ 1.2559")
Inlet:	36.8 ~ 36.9 mm (1.4488" ~ 1.4528")

NOTE

The valve stem and guide must be in good condition, or this check will not be valid.

If the valve seating pattern is not correct, repair the seat (see Valve Seat Repair).

- ◆ Measure the seat width **【E】** of the portion where there is no build-up carbon (white portion) of the valve seat with vernier calipers.

If the width is too wide, too narrow or uneven, repair the seat (see Valve Seat Repair).

VALVE SEAT REPAIR (VALVE LAPPING)

- ◆ Install pilot into valve guide.
- ◆ Apply cutting oil to valve seat and cutter.
- ◆ Place 46° cutter on the pilot and make a light cut.
- ◆ Inspect the cut area of the seat:

If the contact area is less than 75% of the circumference of the seat, rotate the pilot 180° and make another light cut.

If the cutter now contacts the uncut portion of the seat, check the pilot. Look for burrs, nicks, or runout. If the pilot is bent it must be replaced.

If the contact area of the cutter is in the same place, the valve guide is distorted from improper installation.

If the contact area of the initial cut is greater than 75%, continue to cut the seat until all pits are removed and a new seat surface is evident.

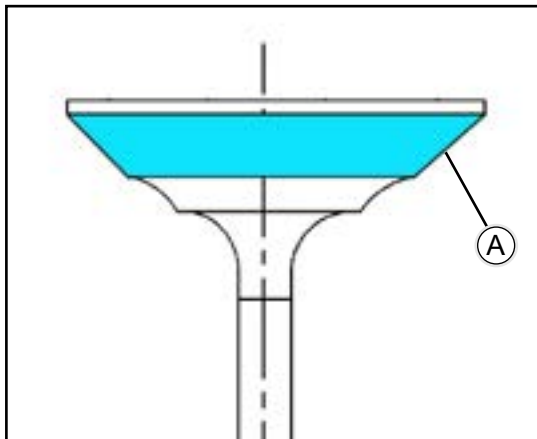

- ◆ To check contact area of the seat on the valve face, apply a thin coating of Prussian Blue™ paste to the valve seat. If using an interference angle (46°) apply black permanent marker to the entire valve face **【A】**.
- ◆ Insert valve into guide and tap valve lightly into place a few times.
- ◆ Remove valve and check where the Prussian Blue™ indicates seat contact on the valve face. The valve seat should contact the middle of the valve face or slightly above, and must be the proper width.

If the indicated seat contact is at the top edge of the valve face and contacts the margin area **【B】** it is too high on the valve face. Use the 30° cutter to lower the valve seat.

If too low, use the 60° cutter to raise the seat. When contact area is centered on the valve face, measure seat width.

If the seat is too wide or uneven, use both top and bottom cutters to narrow the seat.

If the seat is too narrow, widen using the 45° cutter and re-check contact point on the valve face and seat width after each cut.

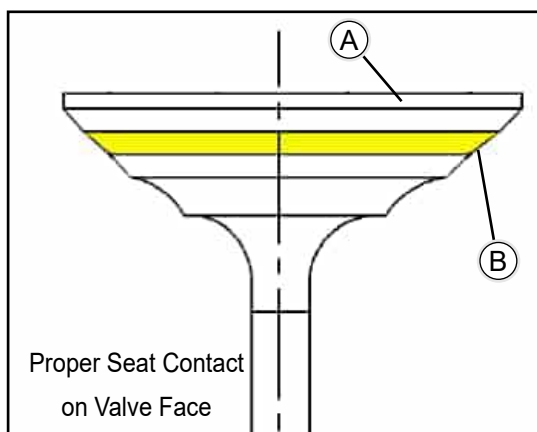

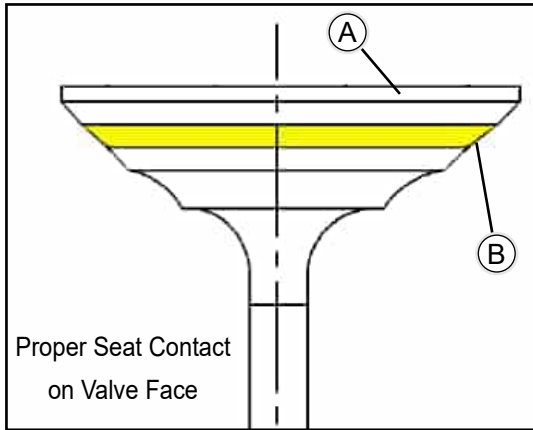

NOTE

When using an interference angle, the seat contact point on the valve will be very narrow, and is a normal condition. Look for an even and continuous contact point all the way around the valve face **【A】**.

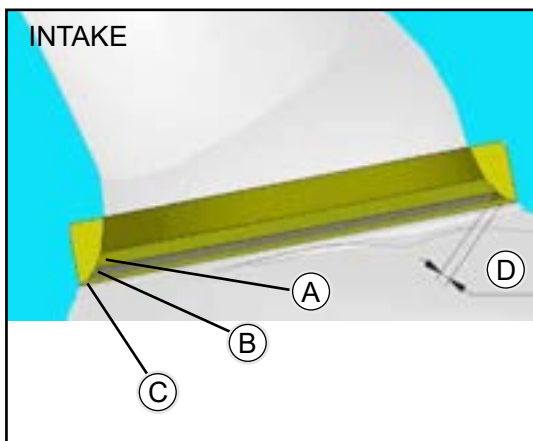

【A】 30°

【B】 45°

【C】 60°

【D】 1.0 ~ 1.1mm (0.0394" ~ 0.0433")

Service Limit: 1.4mm (0.055")

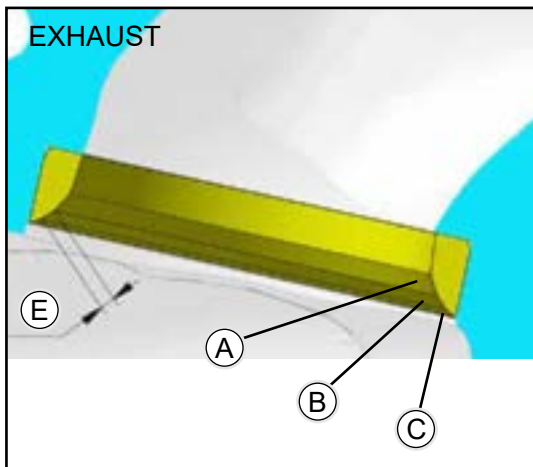

【A】 30°

【B】 45°

【C】 60°

【E】 1.5 ~ 1.6mm (0.0591" ~ 0.0630")

Service Limit: 1.9mm (0.075")

- ◆ Clean all filings from the area with hot soapy water. Rinse and dry with compressed air.
- ◆ Lubricate valve guides with clean engine oil and apply oil or water based lapping compound to the face of the valve.

NOTE

Lapping is not required if an interference angle reconditioning method is used.

- ◆ Insert the valve into its respective guide and lap using a lapping tool or a section of fuel line connected to the valve stem.

- ◆ Rotate the valve rapidly back and forth until the cut sounds smooth. Lift the valve slightly off of the seat, rotate 1/4 turn, and repeat the lapping process. Do this four to five times until the valve is fully seated, and the seating surface is smooth, Then repeat process for the other valve(s).
- ◆ Thoroughly clean cylinder head and valves.

⚠ CAUTION

Do not grind the seat too much. Overgrinding will reduce valve clearance by sinking the valve into the head. If the valve sinks too far into the head, it will be impossible to adjust the clearance, and the cylinder head must be replaced.

CYLINDER AND PISTON

CYLINDER REMOVAL

- ◆ Remove:
 - Cylinder Head (see Cylinder Head Removal)
 - Cylinder Bolt 【A】
 - Cylinder 【B】
 - Cylinder Base Gasket 【C】

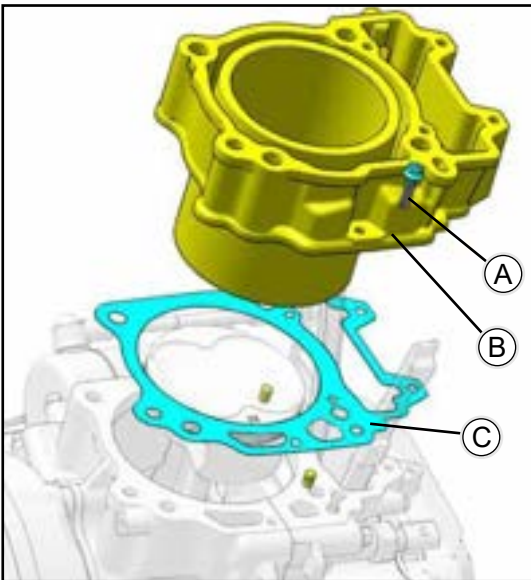

PISTON REMOVAL

- ◆ Remove the cylinder block (see Cylinder Removal).
- ◆ Place a piece of clean cloth under the piston and remove the piston pin snap rings 【A】 from the outside of the piston.

⚠ CAUTION

Do not reuse snap rings, as removal weakens and deforms them. They could fall out and score the cylinder wall.

- ◆ Remove the piston pin 【B】
- ◆ Remove the piston

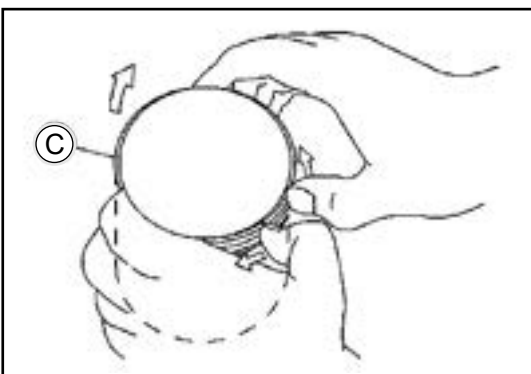
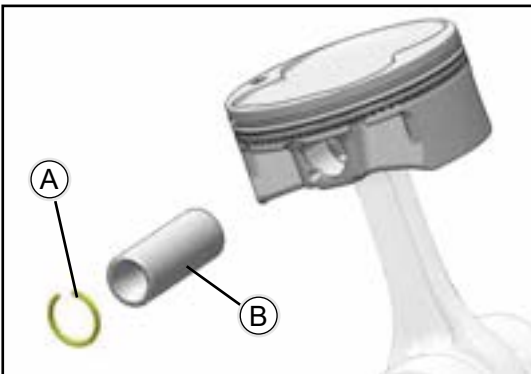
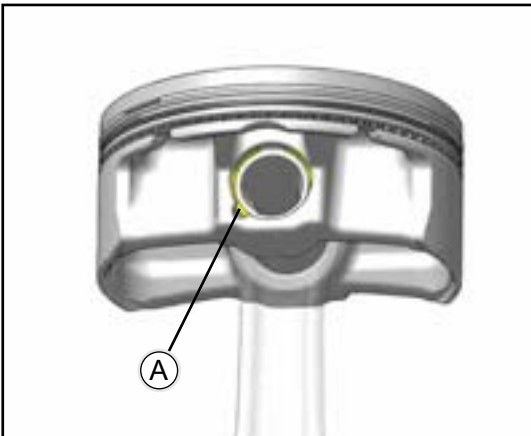

- ◆ Carefully spread the ring opening with your thumbs and then push up on the opposite side of the ring 【C】 to remove it.
- ◆ Remove the 3-piece oil ring with your thumbs in the same manner.

CYLINDER, PISTON INSTALLATION

NOTE

If a new piston or cylinder is used, check piston to cylinder clearance (see Piston/Cylinder Clearance), and use new piston rings.

The oil ring rails have no "top" or "bottom".

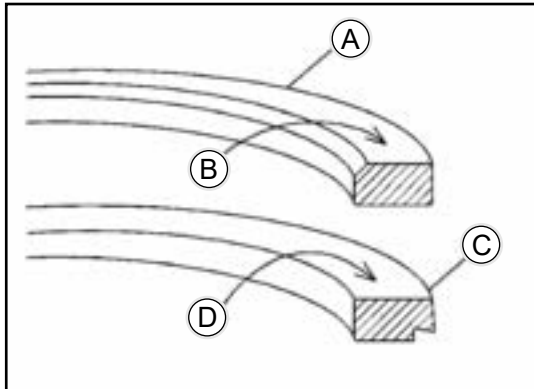
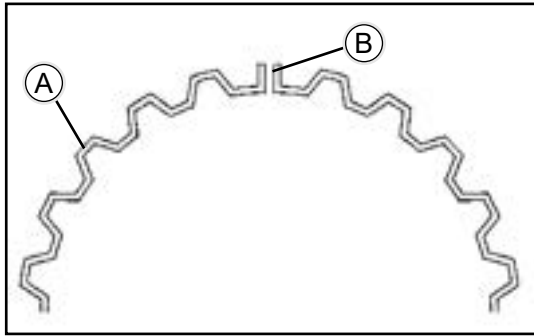

- ◆ Install the oil ring expander **A** in the bottom piston ring groove so the ends **B** butt together.
- ◆ Install the oil ring steel rails, one above the expander and one below it.
 - Spread the rail with your thumbs, but only enough to fit the rail over the piston.
 - Release the rail into the bottom piston ring groove.
- ◆ Do not mix up the top ring and second ring.
- ◆ Install the top ring **A** so that the "A1" mark **B** faces up.
- ◆ Install the second ring **C** so that the "A2" mark **D** faces up.

- ◆ The piston ring openings must be positioned as shown in the figure. The openings of the oil ring steel rails must be about 30° ~ 40° **F** of angle from the opening of the top ring.

Top Ring **A**

Second Ring **B**

Oil Ring Steel Rails **C**

Oil Ring Expander **D**

Note the piston orientation mark (EX) located on top of the piston. (EX) should point toward the exhaust side.

Opening Positions **G**

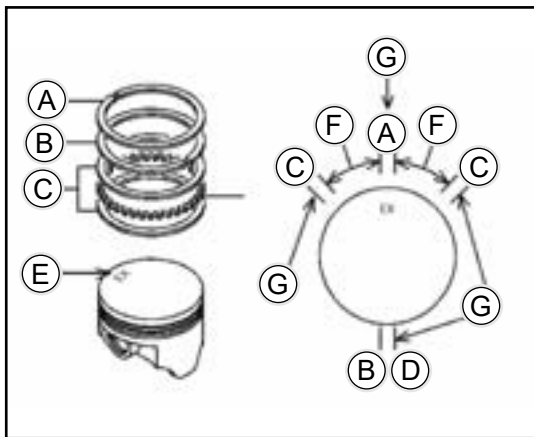

- ◆ Fit a new piston pin snap ring into the side of the piston so that the ring opening **A** does not coincide with the slit **B** of the piston pin hole.
 - When installing the piston pin snap ring, compress it only enough to install it and no more.

- ◆ Apply engine oil to the cylinder bore and, piston skirt.



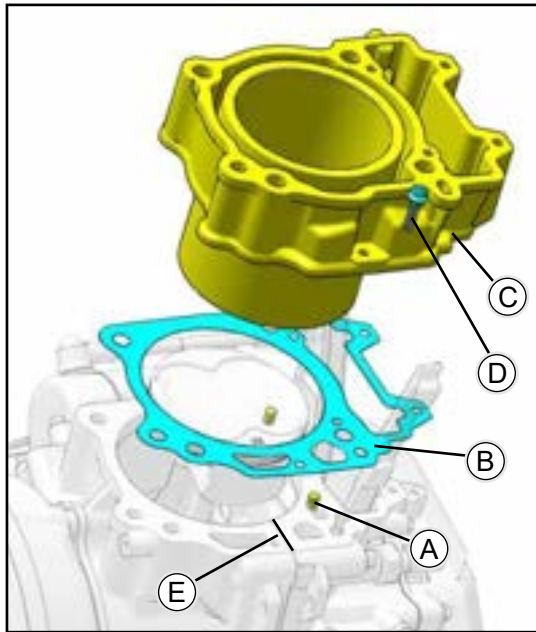

◆ Install:

- Dowel Pins **【A】**
- New Cylinder Base Gasket **【B】**
- Cylinder **【C】**
- Bolt **【D】**

◆ Tighten:

Torque

Bolt 【D】
9.8 N·m (1.0 kgf·m, 87 in·lb)

⚠ CAUTION

Base gasket and surfaces must be DRY and oil free. Use care upon assembly to keep oil away.

- ◆ Apply liquid gasket **【E】** to meeting surface of the crankcase.

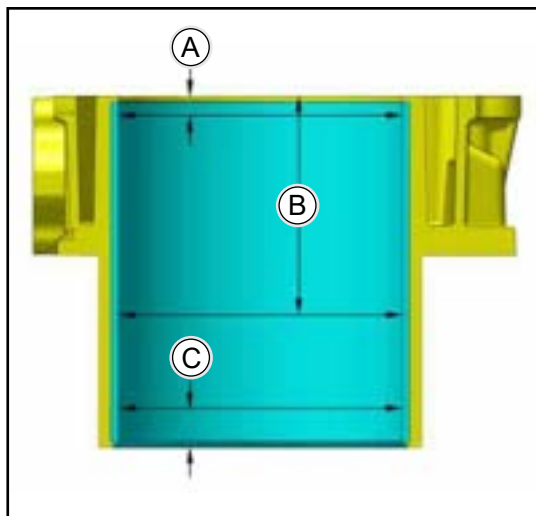

CYLINDER WEAR

- ◆ Since there is a difference in cylinder wear in different directions, take a side-to-side and a front-to-back measurement at each of the three locations (total of six measurements) shown in the figure.

If any of the cylinder inside diameter measurements exceeds the service limit, replace the cylinder.

- 10 mm (0.4 in.) **【A】**
- 60 mm (2.4 in.) **【B】**
- 20 mm (0.8 in.) **【C】**

Cylinder inside Diameter:		
Standard:	I	92.992 ~ 93.000 mm (3.6611" ~ 3.6614")
	II	93.000 ~ 93.008 mm (3.6614" ~ 3.6617")
Service Limit:	I	92.927 mm (3.6585")
	II	99.935 mm (3.6589")

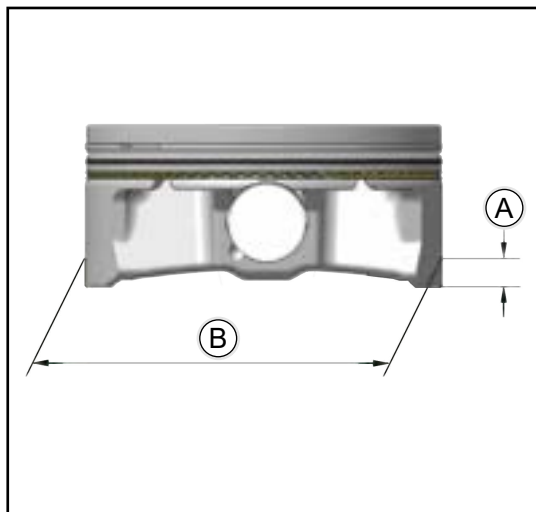

PISTON WEAR

- ◆ Measure the outside diameter **【A】** of each piston 5mm (0.20 in.) **【B】** up from the bottom of the piston at a right angle to the direction of the piston pin.

If the measurement is under service limit, replace the piston.

Piston Diameter:		
Standard:	I	92.951 ~ 92.959 mm (3.6594" ~ 3.6597")
	II	92.959 ~ 92.967 mm (3.6597" ~ 3.66")
Service Limit:	I	92.858 mm (3.6558")
	II	92.885 mm (3.6569")

PISTON/CYLINDER CLEARANCE

- ◆ Subtract the piston diameter from the cylinder inside diameter to get the piston/cylinder clearance.

Piston/Cylinder Clearance

Standard: 0.051 ~ 0.069 mm (0.0020" ~ 0.0027".)

PISTON RING, PISTON RING GROOVE WEAR

- ◆ Check for uneven groove wear by inspecting the ring seating.
- ◆ The rings should fit perfectly parallel to groove surfaces. If not, replace the piston and all the piston rings.
- ◆ With the piston rings in their grooves, make several measurements with a thickness gauge to determine piston ring/groove clearance.

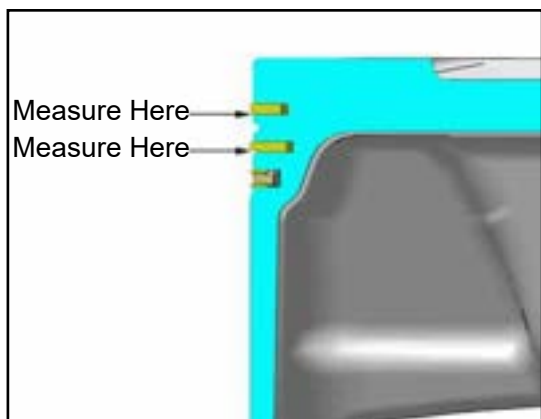

Piston Ring to Groove Clearance:	
Top Ring:	0.020 ~ 0.060 mm (0.0007" ~ 0.0023")
Second Ring:	0.020 ~ 0.060 mm (0.0007" ~ 0.0023")
Service Limit:	0.12 mm (0.0047")

If the piston ring groove clearance is greater than the service limit, measure the ring thickness and groove width as follows to decide whether to replace the rings, the piston or both.

PISTON RING GROOVE WIDTH

- ◆ Measure the piston ring groove width.
 - Use a vernier caliper at several points around the piston.

Piston Ring Groove Width		
	Standard	Service Limit
Top:	1.22 ~ 1.25 mm	1.32mm
Second:	(0.0480" ~ 0.0492")	(0.0520")

If the width of any of the two grooves is wider than the service limit at any point, replace the piston.

PISTON RING THICKNESS

- ◆ Measure the piston ring thickness.
- ◆ Use a micrometer to measure at several points around the ring.

Piston Ring Thickness		
	Standard	Service Limit
Top:	1.17 ~ 1.19 mm	1.10mm
Second:	(0.0461" ~ 0.0469")	(0.0433")

If any of the measurements is less than the service limit on either of the rings, replace all the rings.

⚠ CAUTION

When using new rings in a used piston, check for uneven groove wear. The rings should fit perfectly parallel to the groove sides. If not, replace the piston.

PISTON RING END GAP

- ◆ Place the piston ring **【A】** inside the cylinder, using the piston to locate the ring squarely in place. Set it close to the bottom of the cylinder, where cylinder wear is low.
- ◆ Measure the gap **【B】** between the ends of the ring with a thickness gauge.

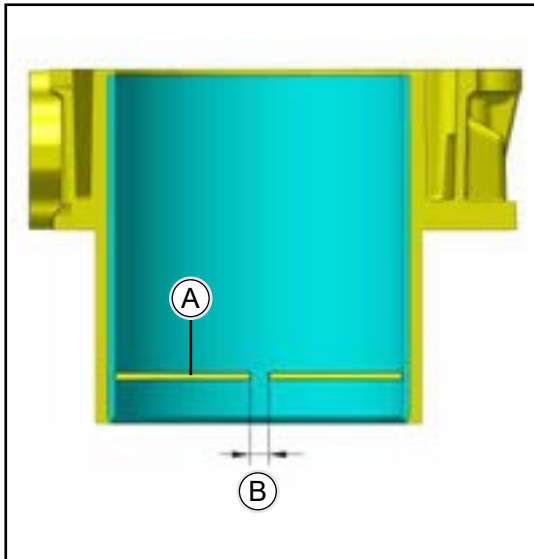

Piston Ring End Gap		
	Standard	Service Limit
Top:	0.20 ~ 0.35 mm (0.0079" ~ 0.0138")	0.5mm (0.0197")
Second:	0.35 ~ 0.55 mm (0.0138" ~ 0.0217")	0.7mm (0.0276")
Oil:	0.20 ~ 0.70 mm (0.0079" ~ 0.0276")	0.9mm (0.0354")

If the end gap of either ring is greater than the service limit, replace all the rings.

CYLINDER HEAD INSTALLATION

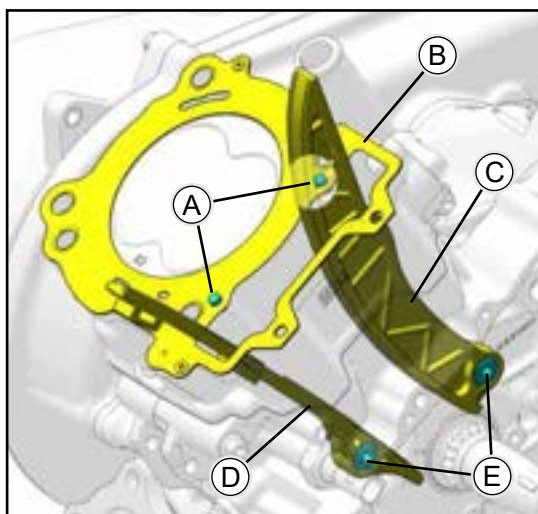

CYLINDER HEAD INSTALLATION

◆ Install:

Dowel Pins 【A】

New Cylinder Head Gasket 【B】

Camshaft Chain Guide 【C】

Camshaft Chain Guide 【D】

Shoulder Bolts 【E】 (using a T40 driver)

◆ Tighten:

Torque

Shoulder Bolts

9.8 N·m (1.0 kgf·m, 87 in·lb)

- ◆ Apply a non-permanent locking agent to the bolts 【E】 .

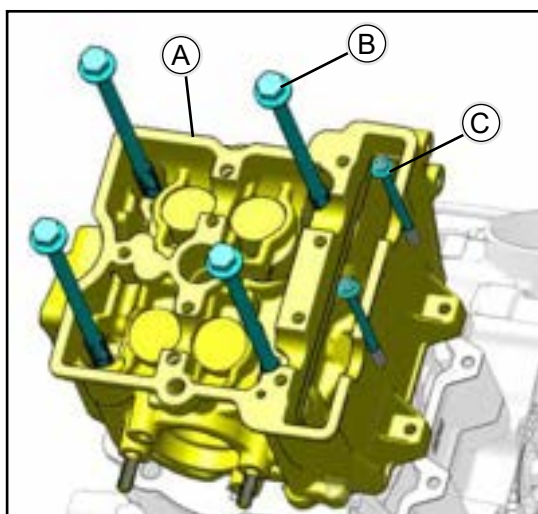

◆ Install:

Cylinder Head Assembly 【A】

Cylinder Head Bolts M11×1.25×150 【B】

Bolts M6×90 【C】

- ◆ Tighten the cylinder head bolts (M11) 【B】 following the tightening sequence as shown.

First Torque

Cylinder Head Bolts (M11) 【B】

25 N·m (2.5 kgf·m, 18 ft·lb)

Final Torque

Cylinder Head Bolts (M11) 【B】

75 N·m (7.7 kgf·m, 54 ft·lb)

Tighten the Bolts M6×90 【C】 .

Torque

Bolts M6×90 【C】

9.8 N·m (1.0kgf·m, 87in·lb)

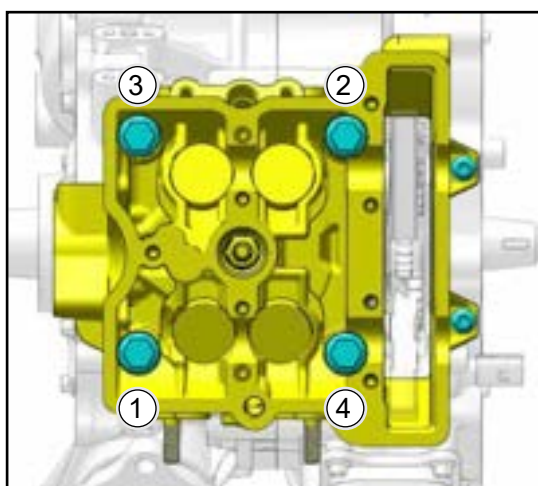

CAMSHAFT INSTALLATION / TIMING

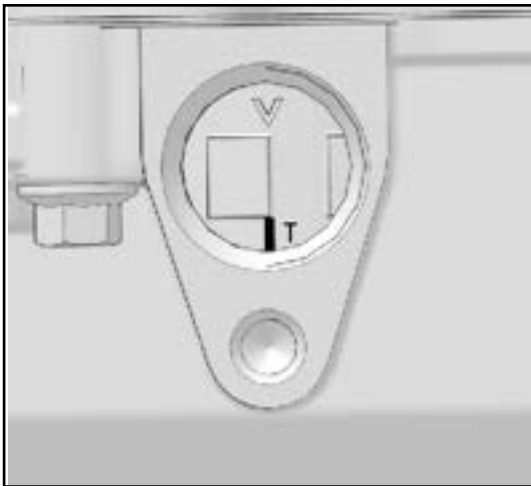

Timing View For Camshafts

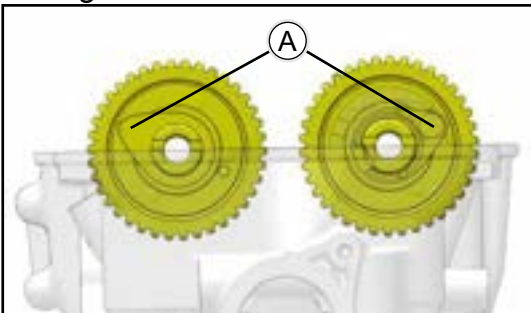

Timing View For Sprockets

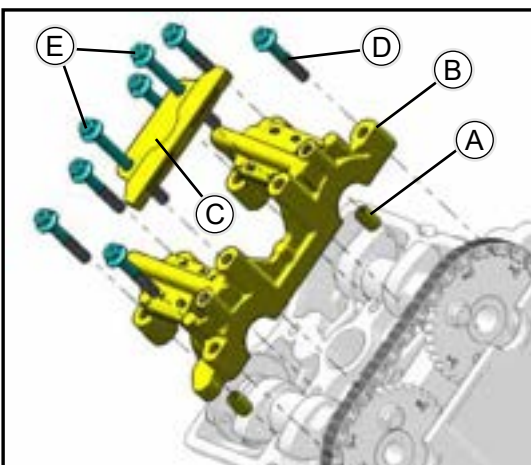
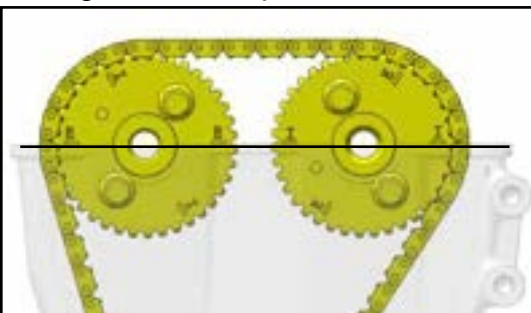

⚠ CAUTION

If any valve train components were replaced, refer to Valve Clearance Adjustment page procedure.

CAMSHAFT INSTALLATION / TIMING

- ◆ Rotate the engine until the flywheel Top Dead Center (TDC) mark is aligned or centered in the Crankshaft Position Sensor (CPS) mounting hole.
- ◆ Reference the intake and exhaust markings made during disassembly. If installing new camshafts or if camshafts were not marked, you can reference the part number stamped on the end of the shafts and compare to the electronic parts catalog.
- ◆ Lubricate all camshaft lobes and bearing journal surfaces with engine oil prior to installation.
- ◆ Carefully install the camshafts into the cylinder head. The camshaft lobes **【A】** should face out as shown.

⚠ CAUTION

Intake cam sprocket should have "I" marks aligned with gasket surface and the exhaust cam sprocket should have "E" marks aligned with gasket surface. Install the exhaust cam sprocket first (opposite the camchain tensioner) to ensure proper cam timing.

- ◆ Install:

Dowel Pins **【A】**

Camshaft Carrier **【B】**

Fixed Cam Chain Guide **【C】**

Bolts M6×35 **【D】**

Bolts M6×65 **【E】**

Carefully install the camshaft carrier onto the camshafts. Carrier openings should face each other when installed properly.

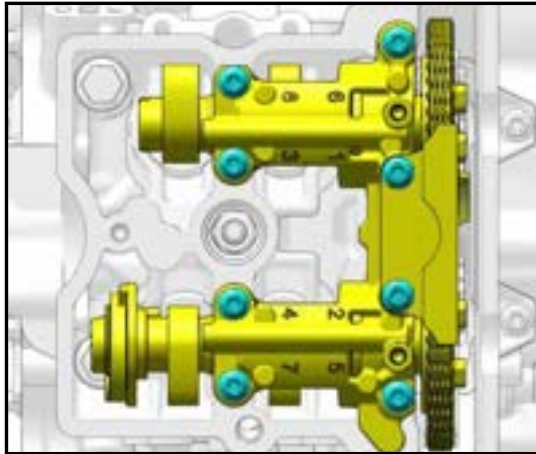

- ◆ Tighten the camshaft carrier bolts (M6) 【D】 and 【E】 following the tightening sequence as shown.

Torque

Bolts M6
9.8 N•m (1.0kgf•m, 87in•lb)

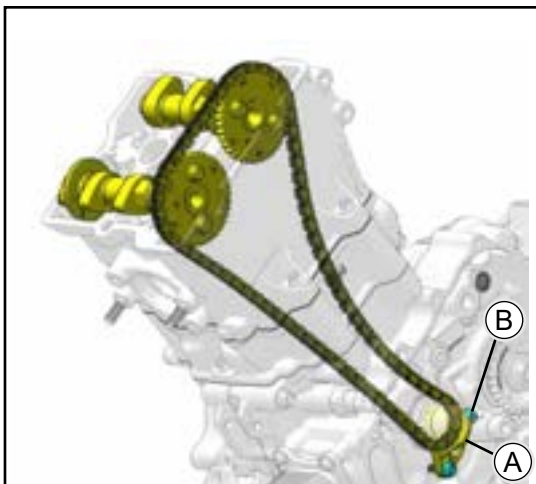

- ◆ Install Chain Guard 【A】
Bolts M6x20 【B】

- ◆ Tighten:

Torque

Bolts M6x20 【B】
9.8 N•m (1.0kgf•m, 87in•lb)

CAMSHAFT CHAIN TENSIONER INSTALLATION

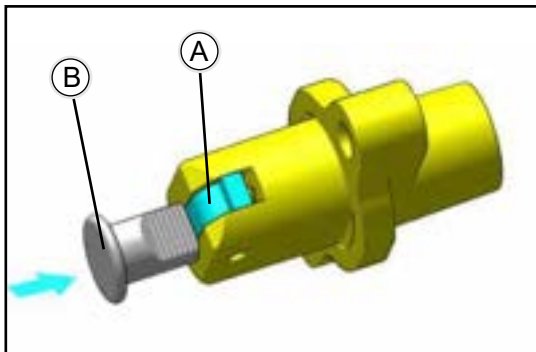

- ◆ Push the stopper 【A】 to release the ratchet and push the push rod 【B】 into the tensioner body.

- ◆ Install

Replace the New Tensioner Gasket 【A】

Tensioner 【B】

Pipe/line Fixing Plate 【C】 and Mounting Bolts 【D】

Spring 【E】 ,O-Ring 【F】 and Tensioner Cap Bolt 【G】

- ◆ Tighten:

Torque

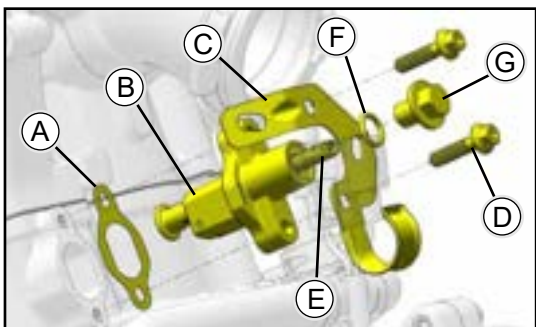

Chain Tensioner Mounting Bolts
9.8 N•m (1.0kgf•m, 87in•lb)

Chain Tensioner Cap Bolt
12 N•m(1.2 kgf•m,8.8 ft•lb)

VALVE CLEARANCE ADJUSTMENT

Timing View For Camshafts

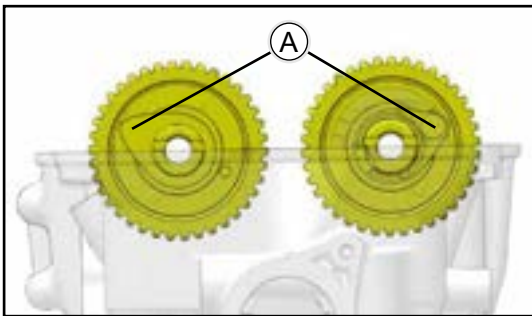

Timing View For Sprockets

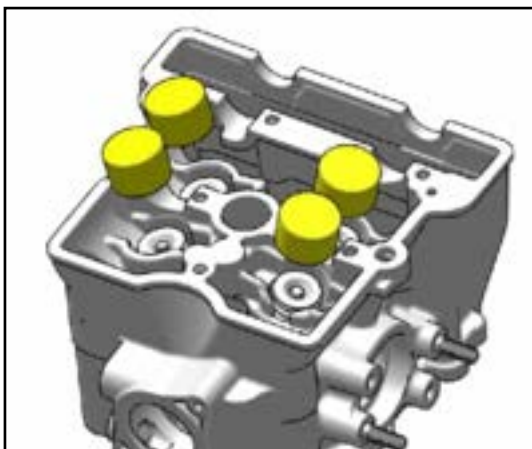
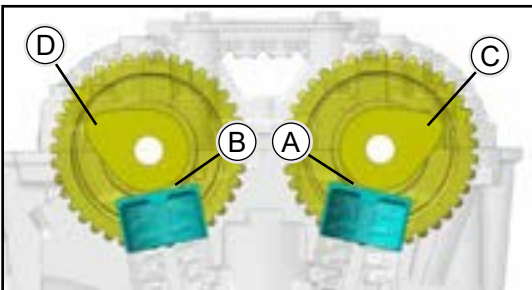
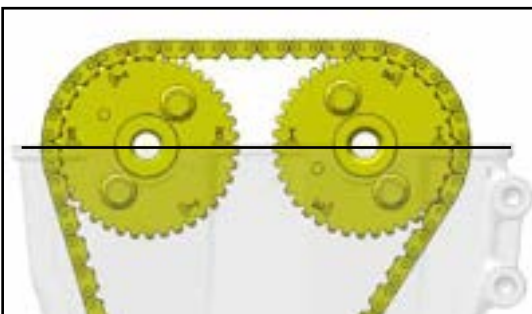

IMPORTANT

Always inspect valve clearance prior to camshaft installation or final engine assembly.

- ◆ Camshaft installation (See the Camshaft Installation / Timing)
- ◆ Camshaft Carrier installation (See the Camshaft Installation / Timing)
- ◆ Rotate the camshaft until the cam lobes **【C】** and **【D】** above the valves you are inspecting are facing up.
- ◆ Measure the valve clearance **【A】** and **【B】** using a thickness (feeler) gauge. Record the measurement if clearance is out of specification.
- ◆ Repeat the above steps until all four valves have been inspected.

Measurement Valve Clearance (cold)	
Exhaust:	0.2 ~ 0.3mm (0.0080" ~ 0.0120")
Inlet:	0.1 ~ 0.2mm (0.0040" ~ 0.0080")

If any of the valve clearance measurements are out of specification, remove the camshaft carriers and camshafts and proceed with this procedure.

- ◆ Remove the valve tappet from a valve that was out of specification.

CAUTION

Keep mated parts together and in order with respect to their location in the cylinder head for assembly purposes. Mark each component or place them in an organized rack as you remove them.

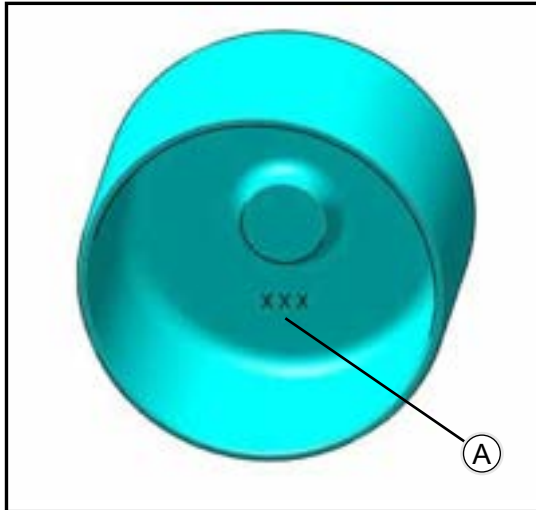

- ◆ Record the 3 digit number on the bottom of the tappet **【A】** .
- ◆ Reference the valve clearance measurement recorded for that valve, along with the 3 digit tappet number.
- ◆ Refer to the appropriate tappet selection matrix (Intake or Exhaust) on the following pages and select the proper tappet.
- ◆ Install the proper tappet.
- ◆ Repeat the above steps until all necessary valves have been adjusted.
- ◆ Reinstall the camshafts and camshaft carriers and tighten the bolts evenly to specification.
- ◆ Tighten:

Torque

Bolts (M6)
9.8 N•m (1.0kgf•m, 87in•lb)

- ◆ Measure and confirm that valve clearance is now within specification for each valve.

If valve clearance is not within specification, repeat this procedure.

If all valve clearance measurements are now within specification, remove the camshaft carriers and proceed to Camshaft Installation / Timing.

VALVE LASH - TAPPET SELECTION

IMPORTANT

The Valve Lash Specification and Measured Valve lash must be calculated in millimeters (mm), A 480 tappet means the thickness of the tappet is 4.80 mm.

- ◆ The proper valve tappet may be obtained by completing these steps:
 1. Subtract the actual valve lash on the engine from the valve lash specification (i.e. 0.27 mm – 0.20 mm) = 0.07 mm.
 2. Divide the 3 digit tappet number by 100 (i.e. 520 / 100) = 5.2 mm.
 3. Add the results of step 1 and step 2 (i.e. 0.07 mm + 5.2 mm) = 5.27 mm.
 4. Multiply that answer by 100 to obtain the correct new tappet (i.e. 5.27 mm × 100 = 527).
 5. Refer to the table below to find the closest available tappet size to the result from step 4 (i. e. 527 should be rounded to 528 since there is a 528 tappet).

Available Tappets

Part Number	F01A20007-	001	002	003	004	005	006	007	008	009	010	011
3 digit number		480	482	484	486	488	490	492	494	496	498	500
Part Number	F01A20007-	012	013	014	015	016	017	018	019	020	021	022
3 digit number		502	504	506	508	510	512	514	516	518	520	522
Part Number	F01A20007-	023	024	025	026	027	028	029	030	031	032	033
3 digit number		524	526	528	530	532	534	536	538	540	542	544
Part Number	F01A20007-	034	035	036	037	038	039	040	041	042	043	044
3 digit number		546	548	550	552	554	556	558	560	562	564	566
Part Number	F01A20007-	045	046	047	048	049	050	051				
3 digit number		568	570	572	574	576	578	580				

VALVE COVER INSTALLATION

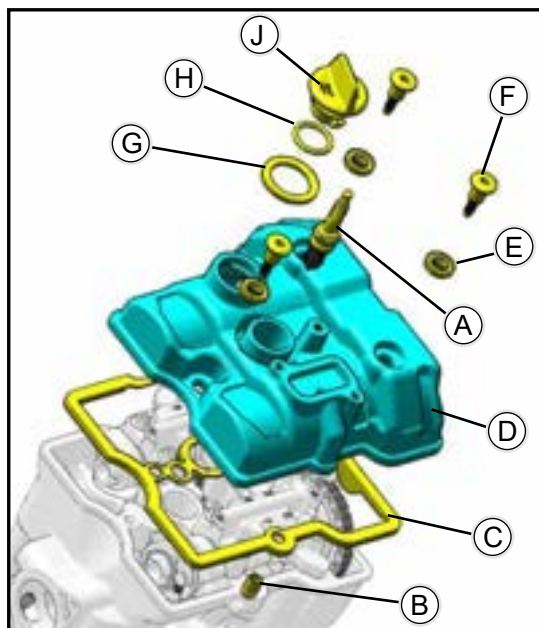

VALVE COVER INSTALLATION

- ◆ Install:
 - Spark Plug 【A】
 - Dowel Pin 10×14 【B】
 - Valve Cover Seal 【C】
 - Valve Cover 【D】
 - New Isolators 【E】
 - Shoulder Bolts 【F】 (using a T40 driver)
 - Oil Fill Cap Seal 【G】
 - O-Ring 22×3 【H】
 - Oil Fill Cap 【J】

- ◆ Tighten:

Torque

Shoulder Bolts 【F】
9.8 N•m (1.0kgf•m, 87in•lb)
Spark Plug 【A】
11 N•m (1.1 kgf•m, 97 in•lb)

CYLINDER COMPRESSION MEASUREMENT

NOTE

Use the battery which is fully charged

- ◆ Warm up the engine thoroughly, and stop the engine.
- ◆ Remove the spark plug (see Electrical System chapter).
- ◆ Attach the compression gauge and adapter firmly into the spark plug hole.
- ◆ Special Tools - Compression Gauge, Compression Gauge Adapter, M10×1.0
- ◆ Hold the throttle wide open and crank the engine with the electric starter several times.
- ◆ When the gauge stops rising, stop cranking and read the gauge.

Cylinder Compression (Usable Range)	
Electric Starter:	450 ~ 700 kPa (4.7~7.2 kgf/cm ² , 65~102 psi) @ 300r/min (rpm)

CYLINDER COMPRESSION

- ◆ The following table should be consulted if the obtainable compression reading is not within the usable range.

Problem	Diagnosis	Remedy (Action)
Cylinder compression is higher than usable range	Carbon accumulation on piston, cylinder head, and in combustion chamber possibly due to damaged valve stem oil seal and/or damaged piston oil rings (This may be indicated by white exhaust smoke).	Remove the carbon deposits and replace damaged parts if necessary.
	Incorrect cylinder head gasket thickness.	Replace the gasket with a standard part.
	Damaged or missing compression release cam spring	Replace the spring.
	Compression release weights do not move smoothly.	Replace the compression release unit.
Cylinder compression is lower than usable range	Gas leakage around cylinder head	Replace damaged gasket and check cylinder head warp.
	Bad condition of valve seating	Repair if necessary.
	Incorrect valve clearance.	Adjust the valve clearance.
	Incorrect piston/cylinder clearance Piston seizure.	Replace the piston and/or cylinder
		Inspect the cylinder and liner and replace/repair the cylinder and/or piston as necessary.
	Bad condition of piston ring and/or piston ring grooves	Replace the piston and/or the piston rings.
	Compression release weights do not move smoothly	Replace the compression release unit

CVT SYSTEM

CVT SYSTEM EXPLOSION DIAGRAM	3-6-2
SPECIAL TOOLS.....	3-6-4
CVT COVER REMOVAL/INSTALLATION	3-6-5
CVT COVER REMOVAL	3-6-5
CVT COVER LINING INSTALLATION	3-6-5
CVT COVER INSTALLATION	3-6-5
CVT INNER COVER REMOVAL	3-6-6
CVT INNER COVER REMOVAL:	3-6-6
CVT INNER COVER INSTALLATION:	3-6-6
DRIVE BELT REMOVAL/INSTALLATION	3-6-7
DRIVE BELT REMOVAL.....	3-6-7
DRIVE BELT INSTALLATION.....	3-6-7
PULLEYS GEOMETRICAL SPECIFICATIONS	3-6-7
DRIVE AND DRIVEN PULLEY REMOVED FROM THE VEHICLE.....	3-6-8
EXPLODED DIAGRAM OF DRIVE ASSEMBLY	3-6-9
DRIVE ASSEMBLY DISASSEMBLY AND INSTALLATION	3-6-10
PULLEY REMOVAL FROM THE VEHICLE	3-6-10
DRIVE PULLEY DISASSEMBLY.....	3-6-11
DRIVE PULLEY RE-ASSEMBLY	3-6-12
TIGHTENING THE PULLEY	3-6-12
PULLEY TIGHTENING.....	3-6-13
CVT DRIVEN PULLEY ASSEMBLY EXPLODED VIEW	3-6-14
PULLEY DISASSEMBLY.....	3-6-15
REMOVING THE DRIVEN PULLEY	3-6-15
SPRING DISASSEMBLY.....	3-6-16
RECOMMENDED INSPECTION	3-6-17
SLIDING FLANGE MAINTEN.....	3-6-18
RECOMMENDED INSPECTION	3-6-18
PULLEY RE-ASSEMBLY	3-6-19
ROLLERS ③ RE - ASSEMBLY	3-6-20

CVT SYSTEM EXPLOSION DIAGRAM

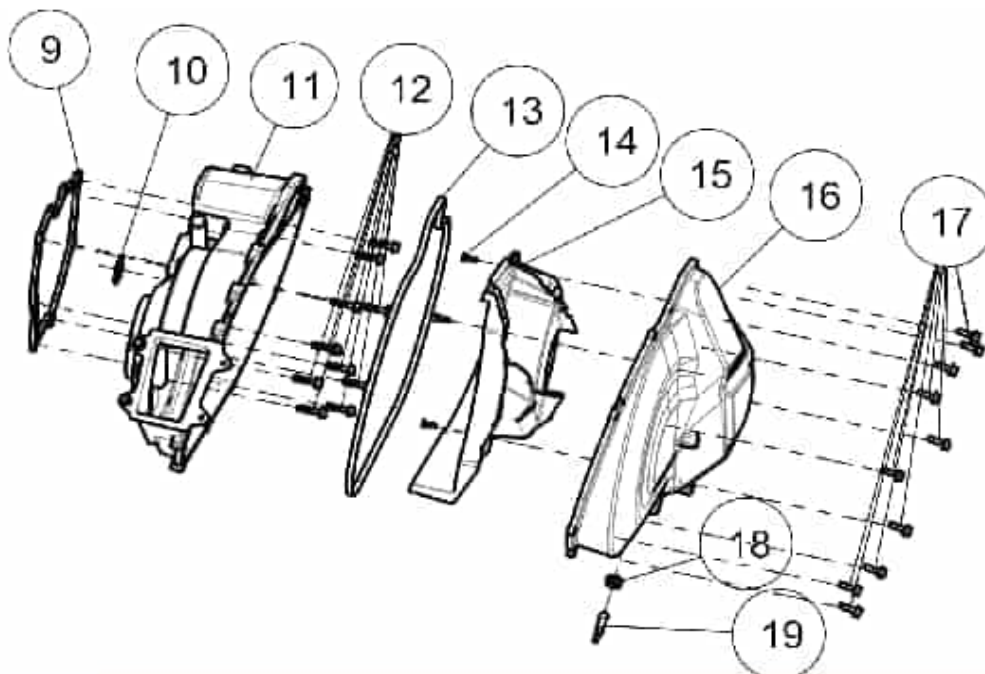
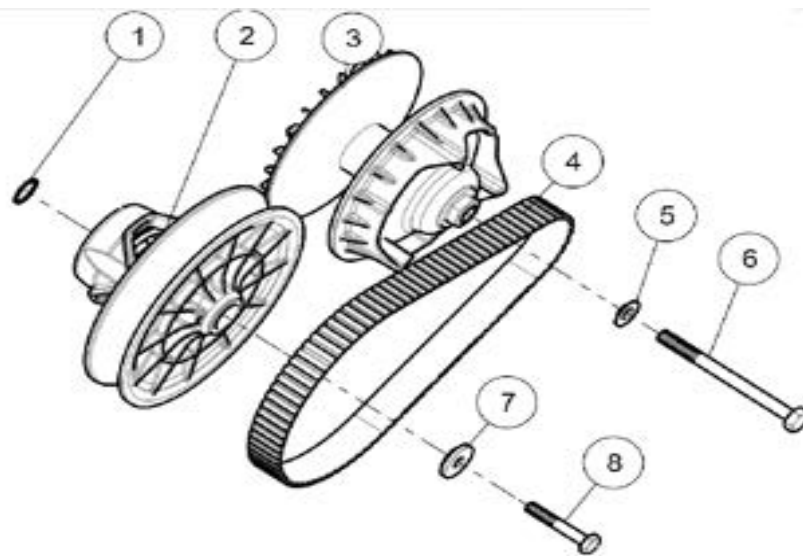
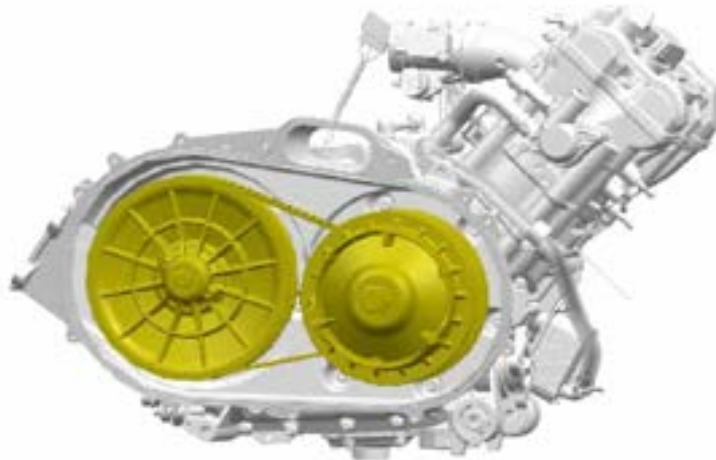

No.	Fastener	Torque			Remarks
		N·m	kgf·m	ft·lb	
1	CVT adjustment spacer				
2	CVT driven wheel				
3	CVT driving wheel				
4	CVT belt				
5	Flanged bushing 12×28×6				
6	CVT driving wheel bolt M12×1.25×142	120	12.2	88	R,Lh
7	Flanged bushing 10.5×36×8				
8	CVT driven wheel bolts	80	8.2	59	R
9	CVT inner cover sealing ring l				
10	O-ring seal 30×3				
11	450CVT inner cover assembly				
12	Bolts M6×28	15	1.5	11	R,L
13	CVT inner box sealing ring				
14	Cross recessed countersunk head screws M5×16	6	0.6	4.6	R,L
15	CVT lining				
16	CVT outer cover				
17	Hexagonal flange bolt M6×20	12	1.2	7	G
18	Water plug sealing ring				
19	Plug				

G:Apply grease for oil seal and O-ring.

L:Apply a non-permanent locking agent.

Lh:Left-hand Threads

R:Replacement Part.

SPECIAL TOOLS

Back-up ring pliers:
E01GZ0060001

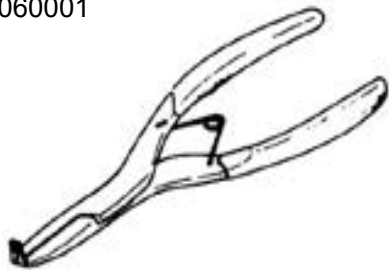

Drive pulley tightening bolt:
E01GZ0000008



Driven wheel jack bolt:
E01-E200001-000-00



Retaining tool:



Alignment Tool



Drive pulley retainer:
E01GZ0000012



Assembly-Disassembly Tool



Vise

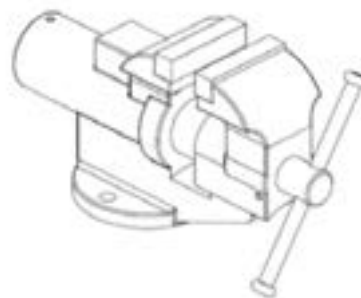

CVT COVER REMOVAL/INSTALLATION

⚠ WARNING

Excessive imbalance or excessive operating speed may cause the continuously variable transmission master and slave to fail, resulting in serious injury or death. The main and driven wheels of a continuously variable transmission are precision balanced components designed to operate within certain speed limits. The disassembly/assembly and repair procedures of the main and driven wheel assemblies must be strictly followed. Modifying the engine or continuously variable transmission to increase rpm may cause malfunction.

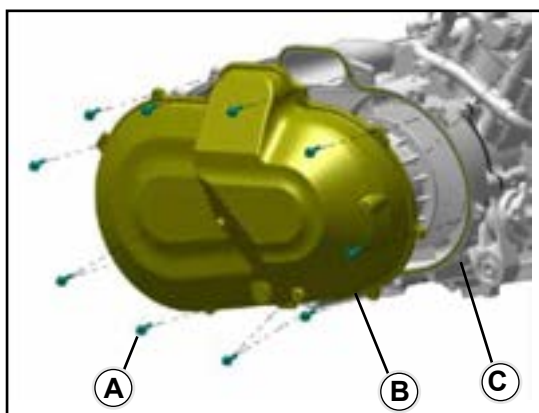
**CVT COVER REMOVAL**

- ◆ Turn off the ignition switch.
- ◆ Demolition
 - CVT outer cover bolt 【A】
 - CVT outer cover 【B】

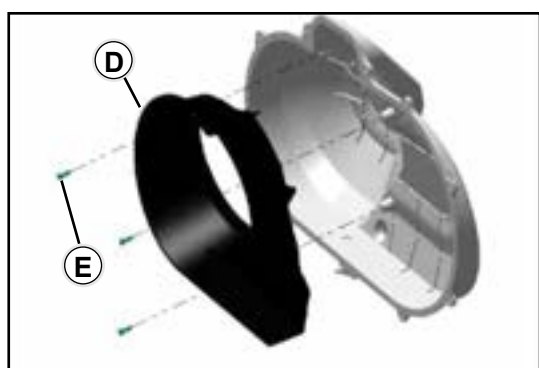
**CVT COVER LINING INSTALLATION**

- ◆ Install the CVT outer cover lining 【D】 into the CVT outer cover.
- ◆ Apply thread locking glue to the M5 screw 【E】 as shown in the picture and tighten it.
- ◆ Torque

CVT cover screws
5N•m (0.5kgf•m)

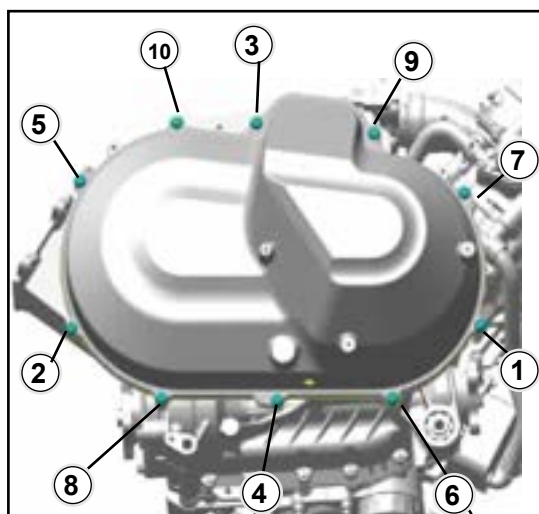
**CVT COVER INSTALLATION**

- ◆ Install the CVT cover plate seal 【C】 into the CVT inner cover sealing groove
- ◆ Tighten the outer cover bolts according to the tightening sequence as shown in the figure.
- ◆ Torque

CVT cover bolt
12N•m (1.2kgf•m)

CVT INNER COVER REMOVAL

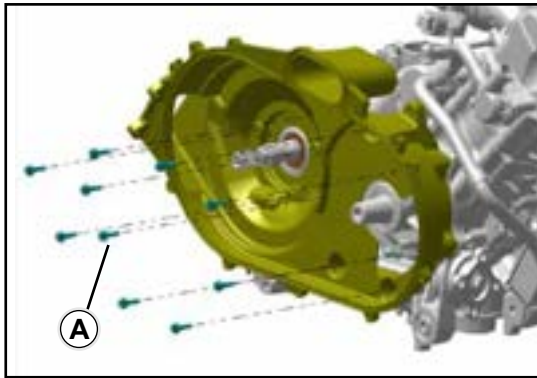

- ◆ Remove the driving wheel and driven wheel (see Disassembling the driving wheel)
- ◆ Removal:
Bolt M8×28 【A】
Remove the CVT inner cover assembly

CVT INNER COVER REMOVAL:

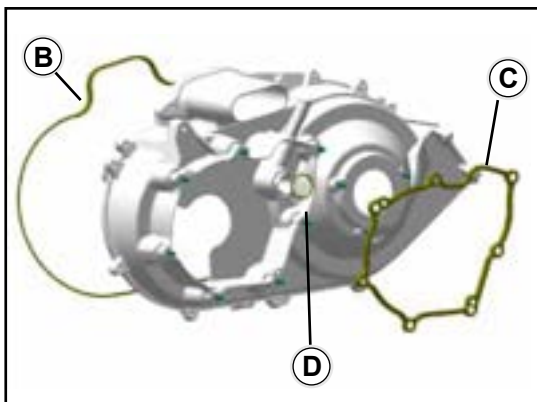

- ◆ Removal:
CVT outer cover seal 【B】
CVT inner cover seal II 【C】
o-ring 30×3 【D】

CVT INNER COVER INSTALLATION:

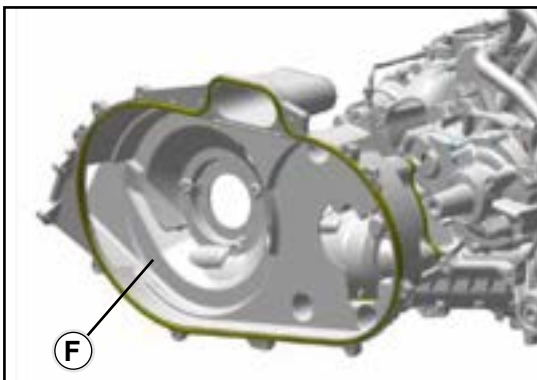

- ◆ If there is obvious water leakage, please replace the CVT outer cover seal 【B】 and CVT inner cover seal II 【C】 .
- ◆ Prepare the CVT inner cover sealing surface for thorough cleaning to remove all residues.
- ◆ Installation:
CVT inner cover assembly 【F】

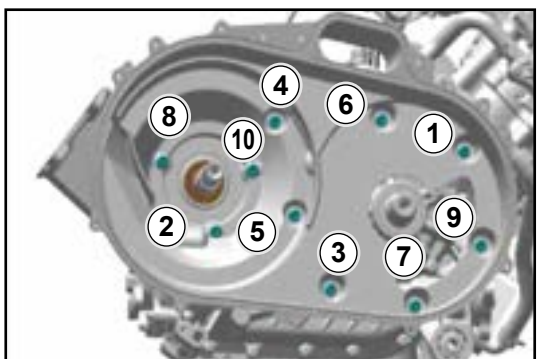

- ◆ Coat the bolts with thread locking glue and tighten the valve cover bolts in the tightening sequence as shown in the figure.

Torque

Bolt
15N•m (1.5kgf•m)

DRIVE BELT REMOVAL/INSTALLATION

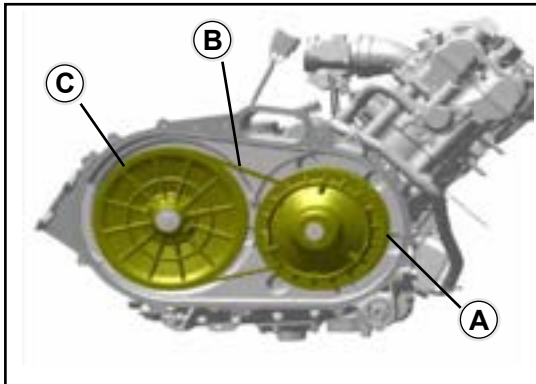

DRIVE BELT REMOVAL

- ◆ Remove the drive pulley **【A】** (see drive pulley removal).

! CAUTION

Before disassembling the transmission belt, please pay attention to the direction of the **【A】** printed on the transmission belt (such as manufacturer name, arrow mark, etc.) so that the transmission belt can be reinstalled on the pulley in the original direction.

- ◆ Lift the transmission belt **【B】** from the driven pulley **【C】**.

DRIVE BELT INSTALLATION

! CAUTION

Make sure the printed information is facing the same direction so that the belt rotates in the same direction as when originally installed. When installing a new belt, install it so that the printed **【A】** message can be read from the side of the vehicle.

- ◆ Installation is basically the opposite of disassembly.
- ◆ Wrap the belt **【B】** around the driven pulley **【C】**.
- ◆ Install the driving pulley (see driving pulley installation).
- ◆ Check the drive belt
- ◆ Please refer to the continuously variable transmission system in the "Periodic Maintenance" chapter.

PULLEYS GEOMETRICAL SPECIFICATIONS

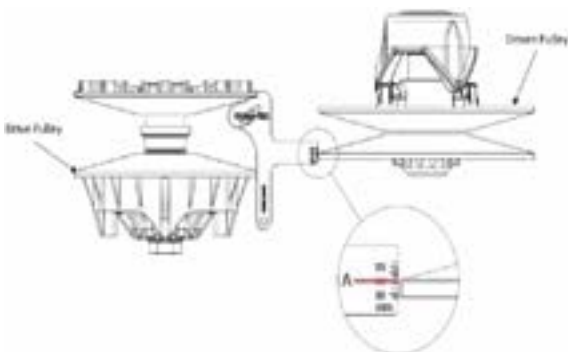

Alignment between pulleys

- ◆ After completing the installation, check the alignment between the pulleys with the alignment tool. Make sure to obtain dimension A and the proper alignment tool part number (refer to owner's manual for both).
- ◆ If dimension A is out of tolerance, you can add or remove shims from the gearbox shaft to help reach it.

DRIVE AND DRIVEN PULLEY REMOVED FROM THE VEHICLE

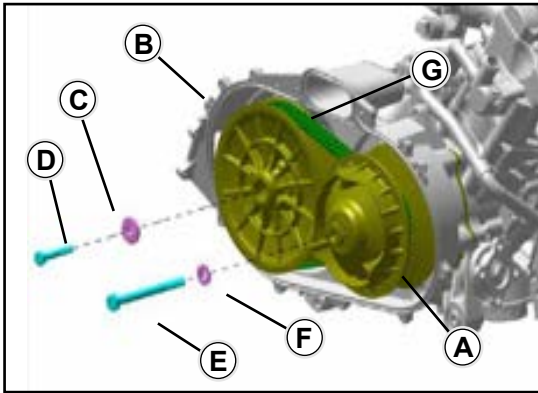

◆ Disassembly:

Remove the CVT outer cover (see CVT outer cover removal)

Loosen the drive pulley bolt 【E】 (left-hand thread)

⚠ CAUTION

The drive wheel bolt is left-hand threaded. Turn the wrench clockwise to loosen.

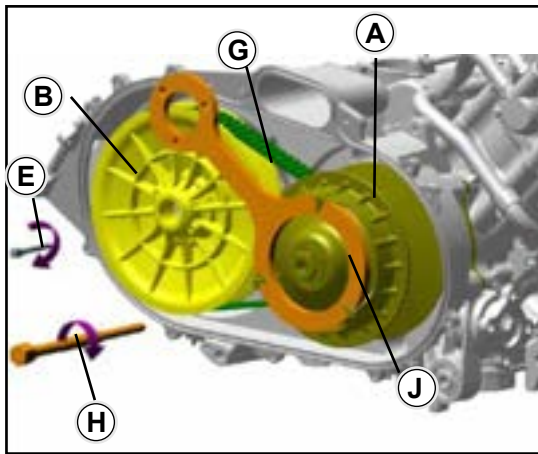

◆ Loosen the driven pulley bolt 【D】 (right thread)

◆ Disassembly:

Drive pulley bolt M12×1.25×142-LH 【E】

Flanged bushing 12×28×6 【F】

Driven pulley bolt M10×1.25×63 【D】

Flange bushing 10.5×36×8 【C】

◆ Tighten the ejector bolt 【E】 of the driven pulley, and separate the belt 【G】 from the driven pulley 【B】 .

◆ Tighten the driving wheel ejector bolt 【H】 clockwise, remove the driving wheel 【A】 from the crankshaft, and hold the driving wheel with the driving wheel clamp 【J】 at the same time.

◆ Special tools,

◆ Drive pulley ejector bolt: E01GZ0000008

◆ Belt ejector bolt: E01-E200001-000-00

◆ Driving wheel clamp:E01GZ0000012

◆ Remove the drive pulley, drive pulley and drive belt.

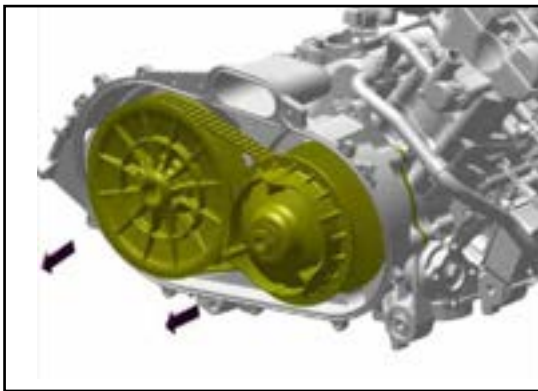

EXPLODED DIAGRAM OF DRIVE ASSEMBLY

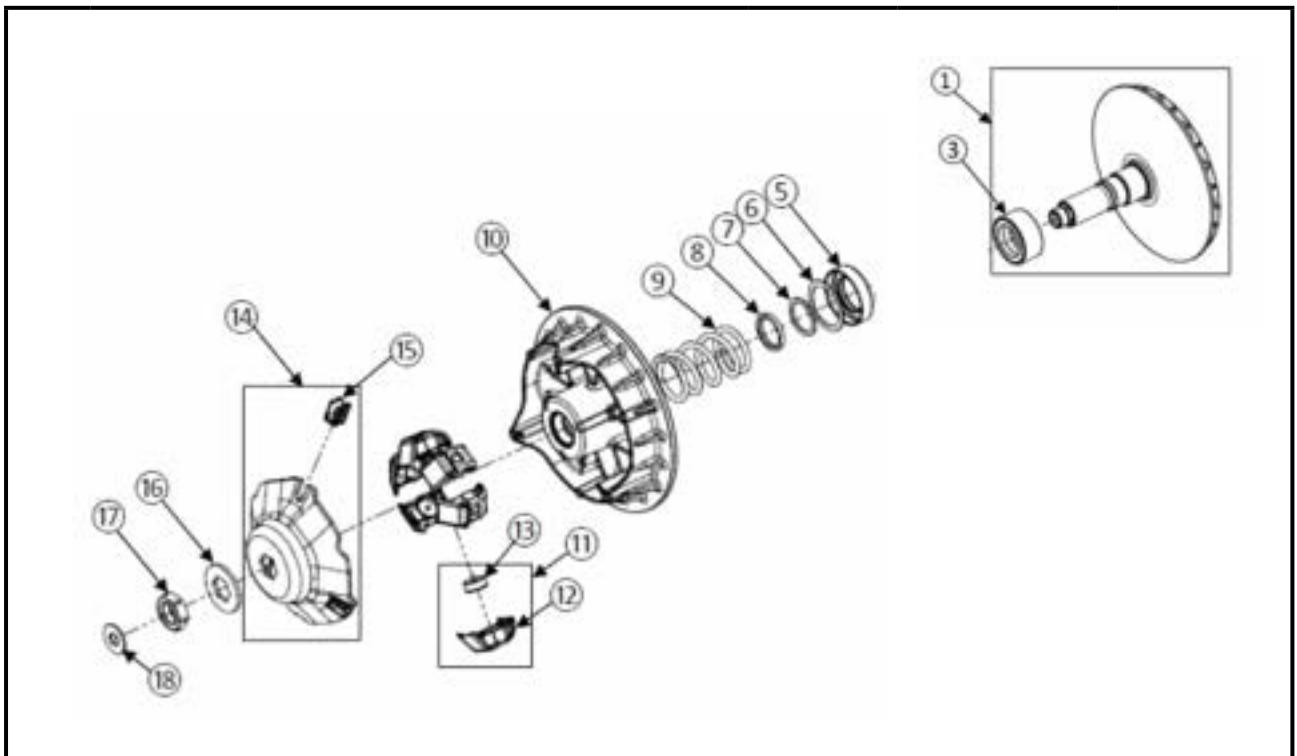

No.	Fastener	Torque			Remarks
		N·m	kgf·m	ft·lb	
1	Fixed sheave				
3	Freewheel or idle bearing				
5	Spring seat				
6	Shim (if applicable)				
7	Shim				
8	Stroke limiter				
9	Spring				
10	Sliding sheave				
11	Centrifugal mass				
12	Block				
13	Mass				
14	Cap				
15	Cap shoe				
16	Washer (If applicable)				
17	Nut	180	18	133	
18	Washer (If applicable)				

DRIVE ASSEMBLY DISASSEMBLY AND INSTALLATION

PULLEY REMOVAL FROM THE VEHICLE

Removing the drive pulley:

- ◆ Remove the fixation bolt from the drive pulley (you will need to use the retaining tool to prevent the pulley from rotating).
- ◆ Screw the puller in the drive pulley shaft and use a breaker bar; torque the puller until the pulley comes off.

NOTE

Hint: apply grease on the tip and on the threads of the puller

- ◆ If the pulley does not come off, please refer to the CVTech document #0046 - 5239 for complementary information on how to remove the drive pulley.

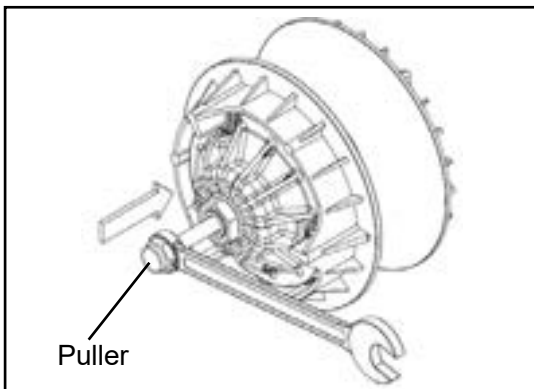
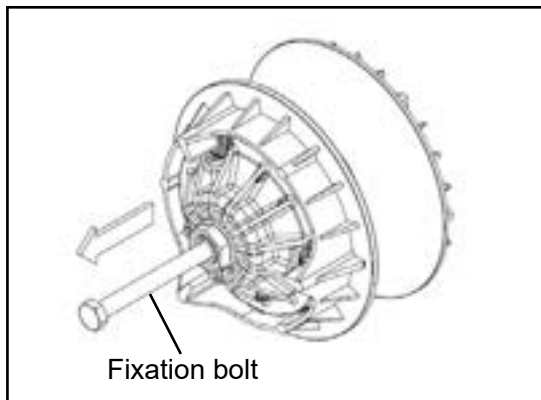
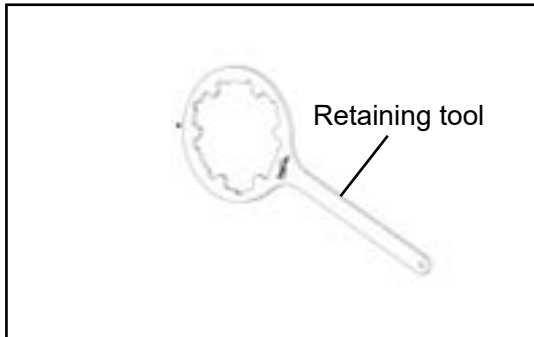

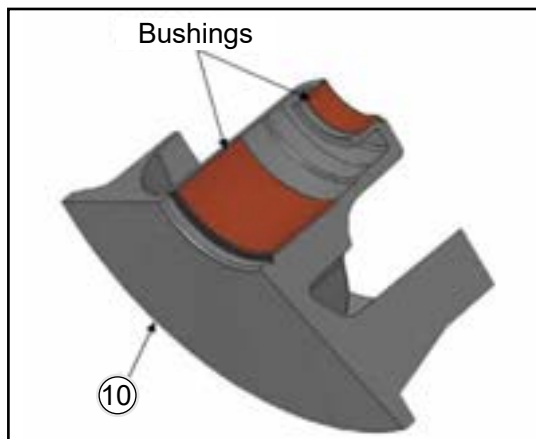
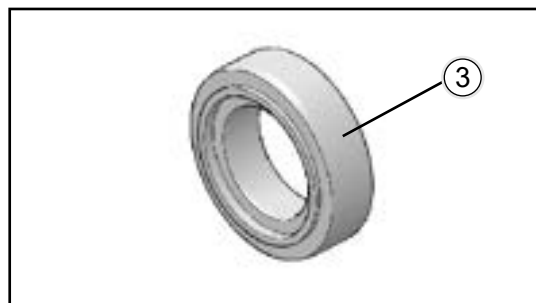
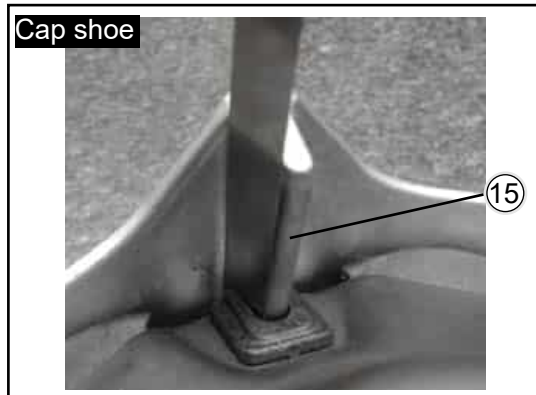
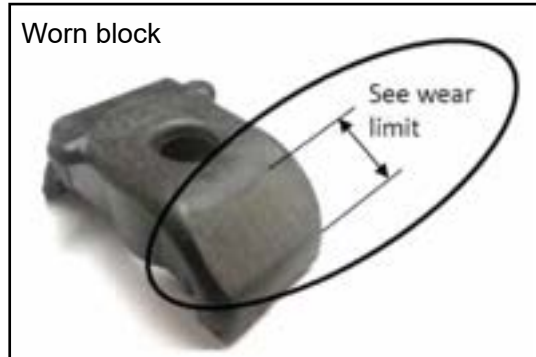

DRIVE PULLEY DISASSEMBLY

Recommended inspection and replacement

1. Check for wear marks on the blocks (12) .
- 1.1. Change the blocks (12) when the wear marks exceed the wear limit. Admissible wear limit of the block is less than 14mm.

Always change all 6 centrifugal blocks (12) at the same time.

2. Check for wear of the cap shoe (15) .
- 2.1. Change cap shoes (15) when a 1mm feeler gauge enters between the cap shoe (15) and sliding sheave (10) tower or if the pulley makes too much noise at idle.

Always change all 3 cap shoes (15) at the same time.

3. Check the Freewheel or idle bearing (3).
- 3.1. Change when an irregular rotation is detected by hand or a creaky noise is heard when rotating the freewheel (3).

Measure the spring (9) forces at the distances indicated on the CVTech website.

NOTE

To maintain the performance of the pulley, make sure the sliding sheave (10) bushings are cleaned with a microfiber towel or dry cloth.

CAUTION

Do not use acetone to clean the bushings.

DRIVE PULLEY RE-ASSEMBLY

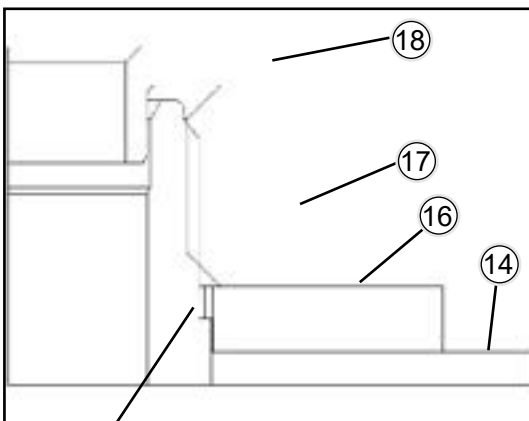
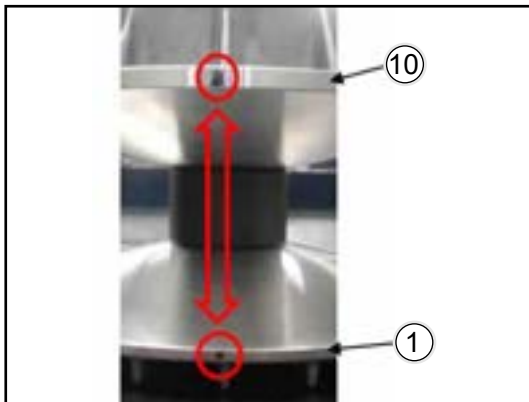
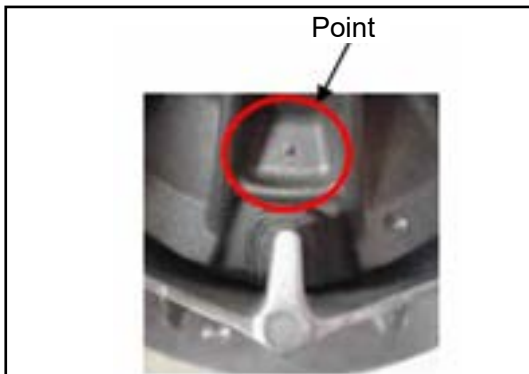
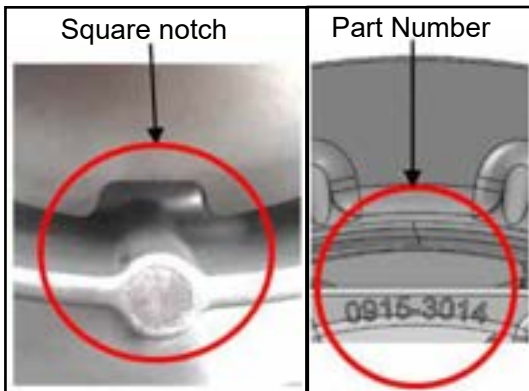

Hexagon top surface
on the pulley shaft

Alignment of fixed sheave ①, sliding sheave ⑩ and cap ⑭.

- ◆ Align the 2 notches on the sheaves ① and ⑩ and also the square shape notch or point or part number on the cap ⑭ (depending on cap model) together to make sure the pulley is balanced.

Nut M4×8

6 N•m (0.6kgf•m, 53in•lb)

TIGHTENING THE PULLEY

- ◆ Use a torque wrench and a 30 mm or 32mm socket (depending on the version of pulley) to tighten the pulley nut ⑰ (see owner's manual for the proper value).

NOTE

- ◆ Make sure the alignment of the hexagon shape of the cap ⑭ and washer ⑯ are fully engaged on the shaft hexagon shape before applying torque to the nut ⑰.

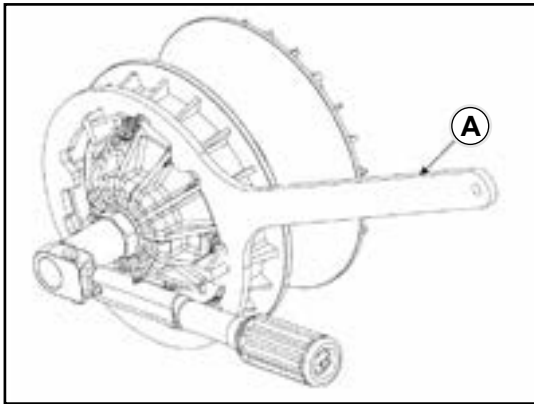

PULLEY TIGHTENING

- ◆ Once the pulley is properly installed, use a torque wrench to tighten the fixation bolt.
- ◆ To tighten the drive pulley, use the retaining tool **【A】** to lock the rotation.

⚠ WARNING

Do not forget to remove the tools from the drive pulley.

NOTE

Before you start the engine:

- ◆ Make sure all the components are clean without any trace of oil, dust and contaminants.
- ◆ Do not use any lubricants.

NOTE

For optimal tightening force

- ◆ Repeat this tightening procedure after traveling a few kilometers with the vehicle.

CVT DRIVEN PULLEY ASSEMBLY EXPLODED VIEW

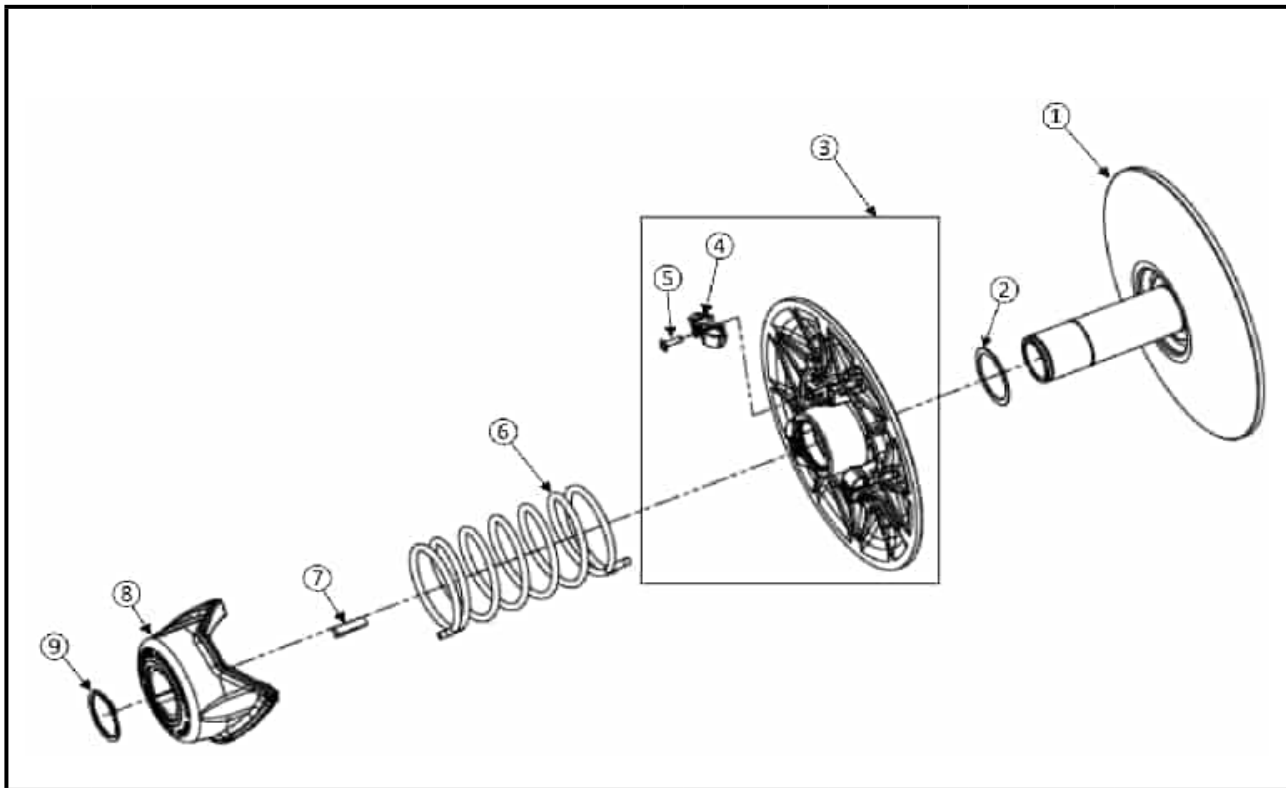

No.	Fastener	Torque			Remarks
		N·m	kgf·m	ft·lb	
1	Fixed Sheave				
2	Washer				
3	Sliding Sheave				
4	Cam shoe				R
5	Cam shoe screw	3.5	0.36		L
6	Spring				
7	Key				
8	Cam				R
9	External retaining ring				

- G:Apply grease for oil seal and O-ring.
- L:Apply a non-permanent locking agent.
- Lh:Left-hand Threads
- M:Apply molybdenum disulfide grease
- R:Replacement Part.

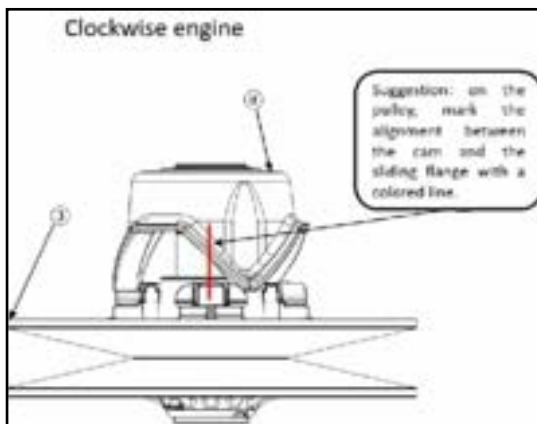
PULLEY DISASSEMBLY**REMOVING THE DRIVEN PULLEY**

- ◆ Make sure you take note of the position of the spring ⑥ in the sliding sheave ③ and cam ⑧ holes, as well as the alignment of the cam ⑧ versus the cam shoe support. When re-assembling the pulley, the positions must be the same as before disassembly. This ensure that pulley performance is not affected.
- ◆ Lock the pulley rotation by engaging in gear and apply the vehicle brakes.
- ◆ Remove the bolt or nut from the driven pulley.

SPRING DISASSEMBLY

- ◆ Using a vise, mount the disassembly tool as shown .

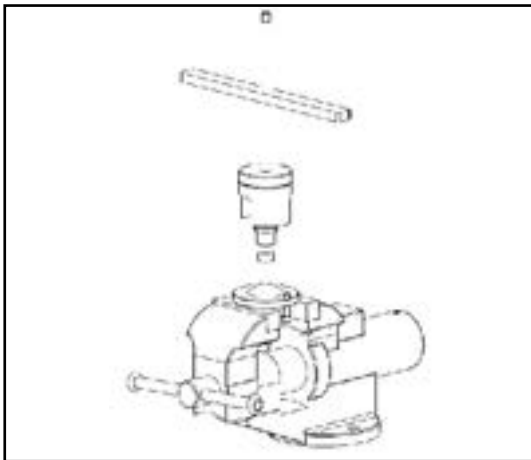

- ◆ Install the pulley on the disassembly tool as shown .Use the lock screw to prevent the rotation of the pulley on the disassembly.
- ◆ By screwing the bar on the threaded rod, press down the spring seat ⑧ (3 to 4 mm max.) in order to free up the external retaining ring ⑨.

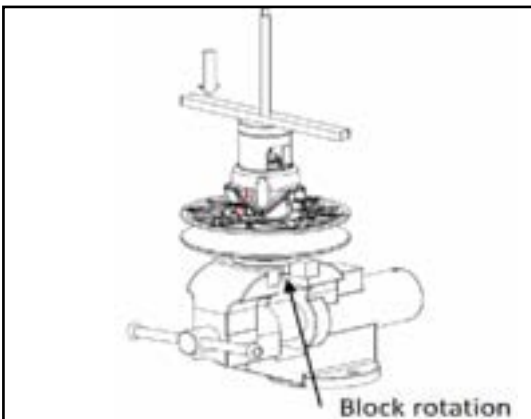

- ◆ Remove the external retaining ring ⑨ using the snap ring pliers.

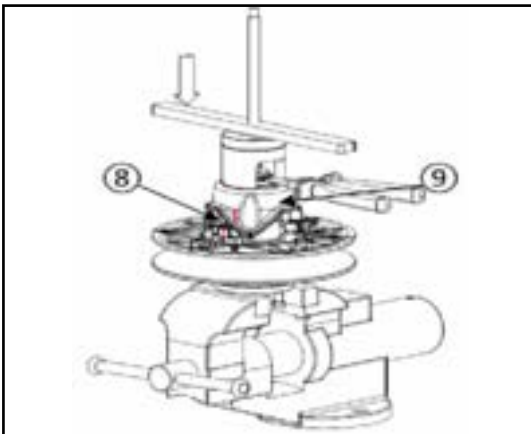

- ◆ Slowly unscrew the bar on the threaded rod to release the spring ⑥ tension.

⚠ WARNING

Use the disassembly tool to disassemble the cam ⑧. The pulley is spring loaded with significant amount of force; the use of the disassembly tool will keep the pulley compressed.

⚠ WARNING

Slowly lift the cam ⑧ to free it from the shaft by unscrewing the disassembly tool once the external retaining ring ⑨ is removed.

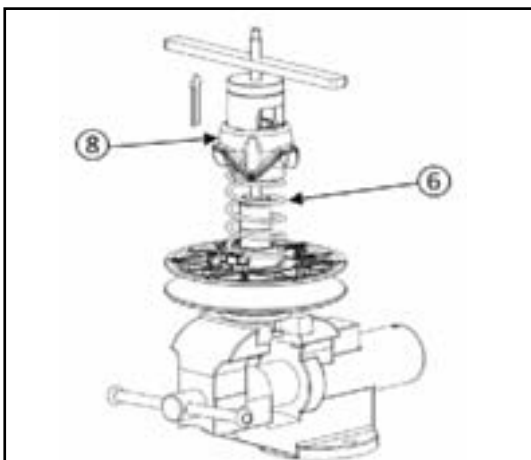

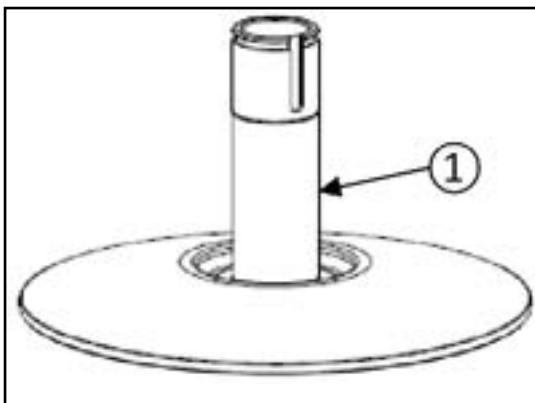
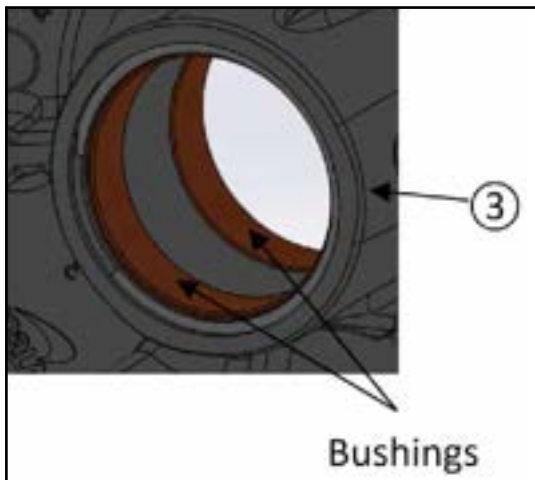

RECOMMENDED INSPECTION

- ◆ Check for wear marks on the cam ⑧.
- ◆ Check for wear marks on the spring ⑥.
- ◆ Perform a visual inspection of the compone.
- ◆ Check the wear of the sliding sheave ③ bushings(visual inspection only). If there is excessive wear, you must replace the whole sheave assembly ③.

⚠ WARNING

The bushings cannot be removed from the sliding sheave ③ .

⚠ WARNING

The shaft cannot be disassembled from the fixed sheave ① .

⚠ WARNING

To maintain the performance of the pulley, make sure the sheave bushings are cleaned with a microfiber towel or dry cloth. CAUTION: Do not use acetone to clean bushing and do not use any lubricant.

SLIDING FLANGE MAINTEN

RECOMMENDED INSPECTION

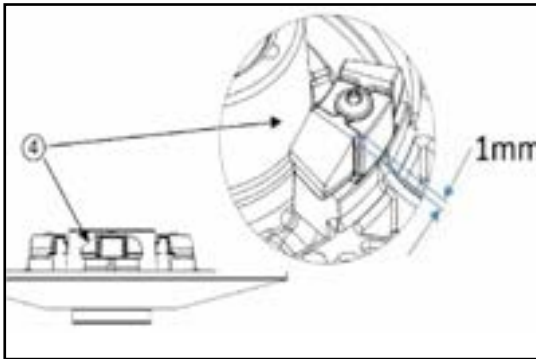

- ◆ If the cam shoes ④ are worn down to about 1 mm before making contact with the cam shoe support, they must be replaced.

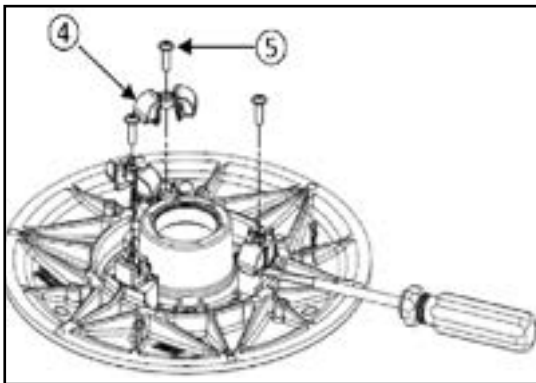

- ◆ After removing the cam shoe screws ⑤ with a No. 20 torx screwdriver, the camshoes ④ may be removed using a flathead screwdriver.

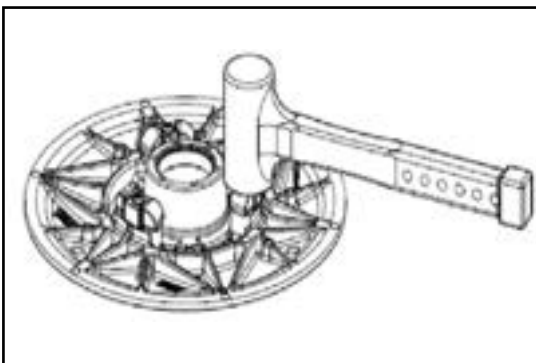

- ◆ PMount the new cam shoes ④ using a hamme.

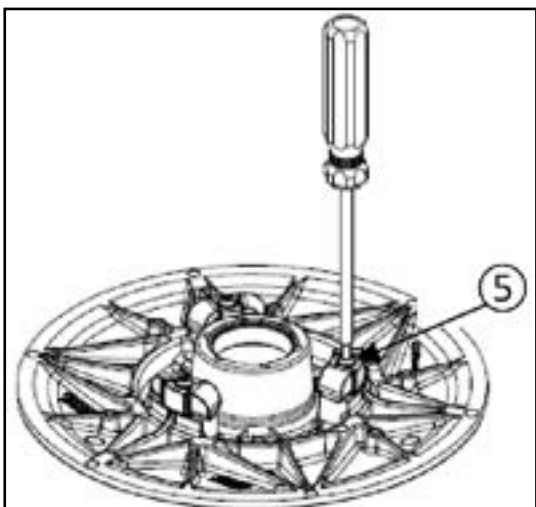

- ◆ Tighten the cam shoe screws ⑤ using no. 20 torx screwdriver to a value of 3.5N.m.

PULLEY RE-ASSEMBLY

- ◆ The use of the disassembly tool is required in order to re - assemble the pulley

Pulley re-assembly

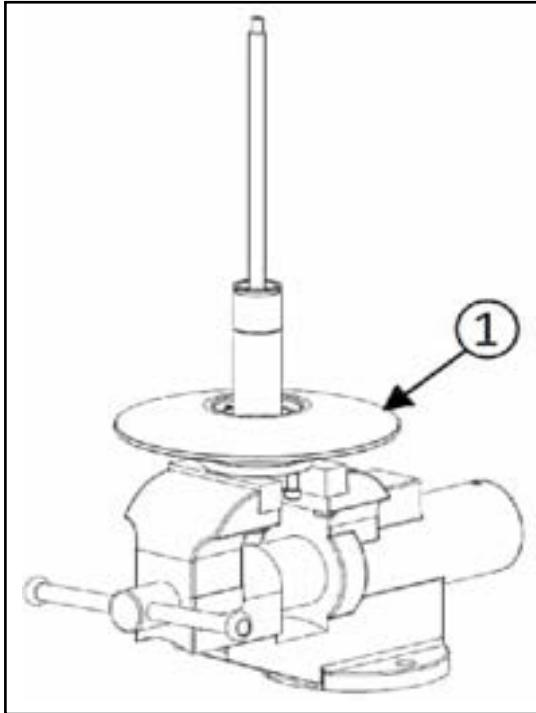

- ◆ Install the fixed sheave ① on the disasse

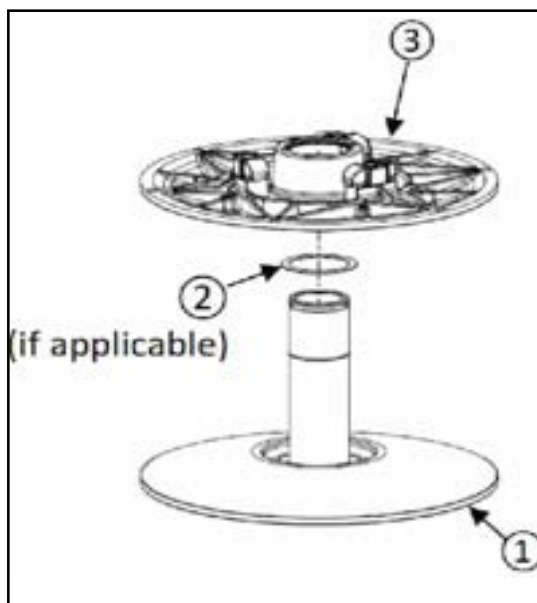

- ◆ Put the washer ② (if applicable) on the fixed sheave ① then put the sliding sheave ③ .

ROLLERS ③ RE - ASSEMBLY

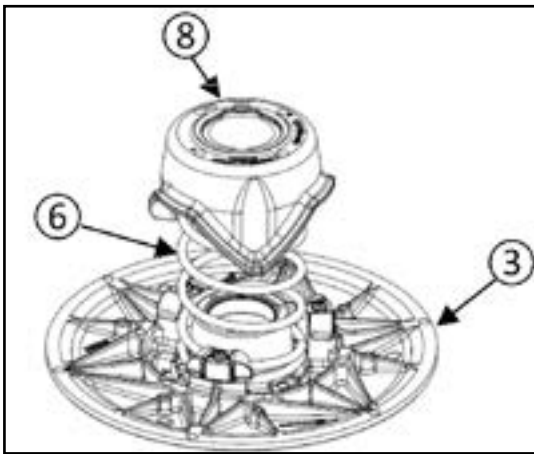

- ◆ Place the spring ⑥ lugs into the proper cam ⑧ hole and the proper sliding sheave ③ hole at the same positions noted during the disassembly steps .

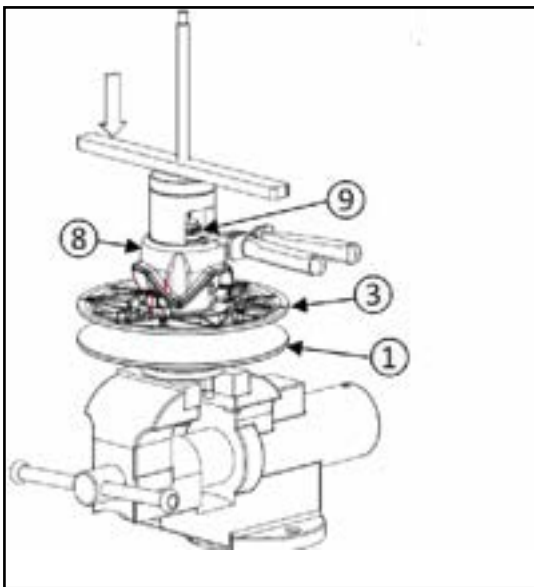

- ◆ Press down the cam ⑧ onto the fixed sheave ① shaft with the disassembly tool. Position the key ⑦ into the fixed sheave ① shaft groove

- ◆ Put the retaining ring ⑨ on Torque the 4 screws .

- ◆ Make sure that the fixed sheave ① is blocked in rotation, turn the sliding sheave ③ counter clockwise or clockwise to position the cam shoe ④ on the proper side of the cam sliding surface as it was before disassembly

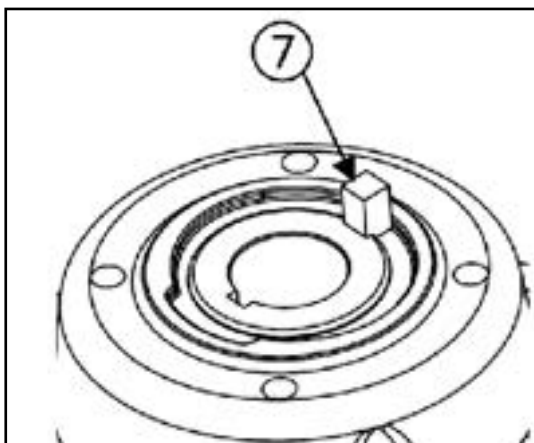

- ◆ Screw the disassembly tool bar until the cam ⑧ is low enough to install the external retaining ring

FRONT AND REAR DIFFERENTIAL

TECHNICAL SPECIFICATIONS	4-2
SPECIAL TOOLS	4-3
EXPLODED VIEW OF FRONT AXLE	4-5
REAR AXLE WITH DIFFERENTIAL EXPLOSION DIAGRAM	4-7
DIAGRAM OF REAR AXLE EXPLOSION WITHOUT DIFFERENTIAL	4-9
FRONT AXLE GEAR OIL REPLACEMENT	4-11
DRAIN FRONT AXLE OIL	4-11
ADD FRONT AXLE OIL.....	4-11
DISASSEMBLE AND REPLACE OIL SEAL	4-12
DISASSEMBLE THE CROSS JOINT.....	4-12
DISASSEMBLE AND REPLACE OIL SEAL	4-13
INSTALL THE CROSS JOINT	4-13
DIFFERENTIAL REAR AXLE GEAR OIL REPLACEMENT	4-14
DRAIN DIFFERENTIAL REAR AXLE OIL	4-14
ADD DIFFERENTIAL REAR AXLE OIL.....	4-14
DISASSEMBLE AND REPLACE OIL SEAL	4-15
DISASSEMBLE THE CROSS JOINT.....	4-15
DISASSEMBLE AND REPLACE OIL SEAL	4-16
INSTALL THE CROSS JOINT	4-16
NON-DIFFERENTIAL REAR AXLE GEAR OIL REPLACEMENT	4-17
DRAIN DIFFERENTIAL REAR AXLE OIL	4-17
ADD DIFFERENTIAL REAR AXLE OIL.....	4-17
OIL SEAL REPLACEMENT AND ASSEMBLY	4-18
DISASSEMBLE AND REPLACE OIL SEAL	4-18
DISASSEMBLE THE CROSS JOINT.....	4-18
DISASSEMBLE AND REPLACE OIL SEAL	4-19
INSTALL THE CROSS JOINT	4-19

TECHNICAL SPECIFICATIONS

Item	Standard	Service Limit
Front axle assembly:		
model	SAE 80W/90 API GL-5	
gas station	Side (M18 screw plug)	
Oil drain port	Bottom (M14 screw plug)	
volume	190 mL (first refill) 170 mL (replace oil)	
Bevel gear backlash	0.15~0.25 mm(0.06~0.10 in.)	

Item	Standard	Service Limit
Rear axle differential assembly:		
model	SAE 80W/90 API GL-5	
gas station	Side (M18 screw plug)	
Oil drain port	Bottom (M14 screw plug)	
volume	280 mL (first refill) 260 mL (replace oil)	
Bevel gear backlash	0.15~0.25 mm(0.06~0.10 in.)	

Item	Standard	Service Limit
Rear axle without differential assembly:		
model	SAE 80W/90 API GL-5	
gas station	Side (M18 screw plug)	
Oil drain port	Bottom (M14 screw plug)	
volume	140 mL (first refill) 120 mL (replace oil)	
Bevel gear backlash	0.15~0.25 mm(0.06~0.10 in.)	

SPECIAL TOOLS

Allen wrench 8mm / 12mm:

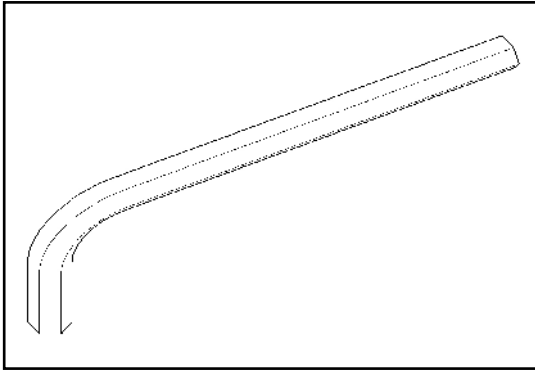

Silicone rubber flat sealant:

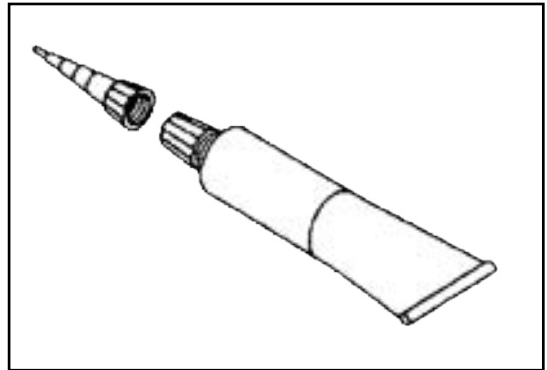

External circlip pliers

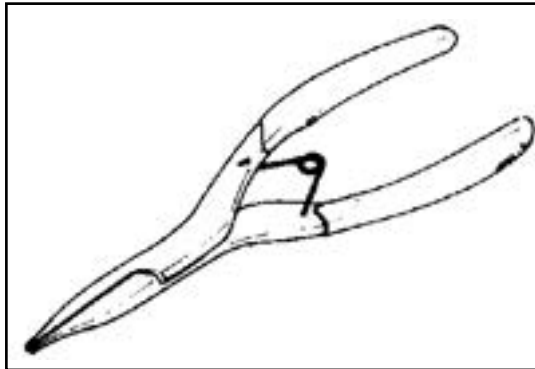

Screwdriver

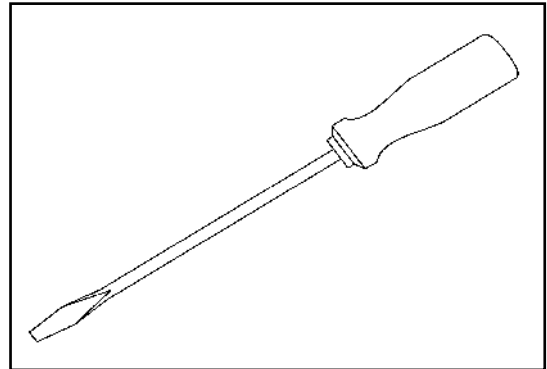

Work fixture:

Name: Oil seal 48×65×9 tooling



Work fixture:

Name: Oil seal 24×38×8 tooling



Work fixture:

Name: Oil seal 30×45×6.5 tooling



Work fixture:

Name: Oil seal 35×56×8 tooling



EXPLODED VIEW OF FRONT AXLE

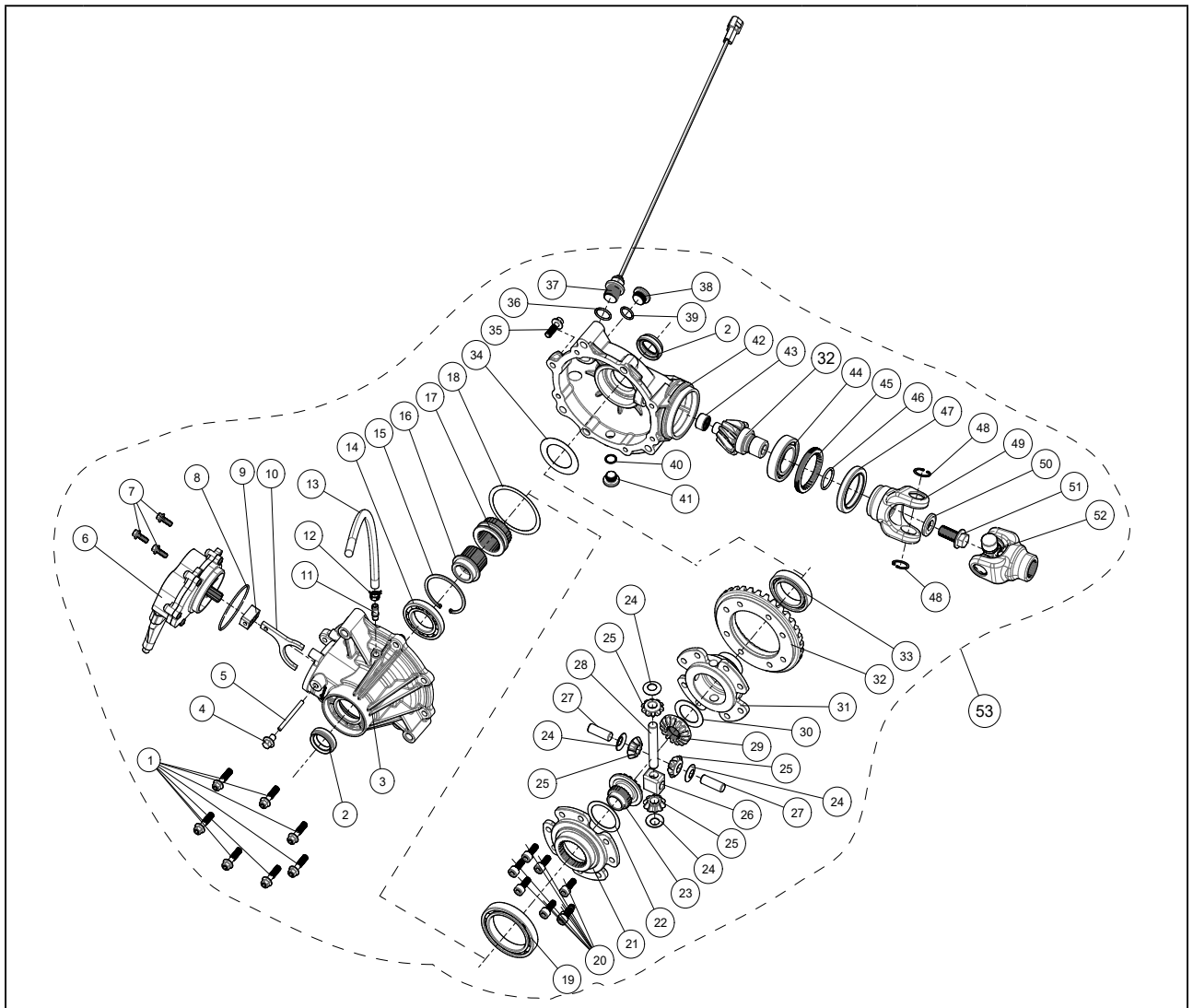

No.	Fastener	Torque			Remarks
		N·m	kgf·m	ft·lb	
1	bolt M8×30	25	2.55	18.5	L
2	oil seal 24×38×8				G
3	Front axle box cover				
4	Hexagonal flange bolts M8×12	24	2.4	17	L
5	Fork shaft O				O
6	Front axle shift motor assembly				
7	bolts M6×16	10	1	7	
8	O-ring 67.9*2.2				O
9	sliding rack				O
10	shift fork				O
11	Breather pipe connector				
12	Steel belt elastic hose clamp				
13	snorkel				
14	Deep groove ball bearing 16007				O
15	hole retaining ring 62				
16	output sets				O
17	Combined with dial set				

FRONT AND REAR DIFFERENTIAL

SEGWAY AT5

No.	Fastener	Torque			Remarks
		N·m	kgf·m	ft·lb	
18	washers				
19	Deep groove ball bearing 61912 O				O
20	Hexagon socket head screws M8×20 (black zinc)	25	2.55	18.5	L
21	differential cover				
22	Left side gear spacer				
23	Left side bevel gear				
24	Planetary gear spacer				
25	planetary gears				O
26	planetary axis carrier				
27	Planetary gear shaft I				
28	28 Planetary gear shaft II				
29	29 Right half shaft bevel gear				O
30	30 Right side gear spacer				
31	31 differential housing				
32	32 Master and driven bevel gear combination (450 front axle)				
33	33 Deep groove ball bearing 61908				0
34	34 bevel tooth adjustment washer				
35	35 Hexagonal flange bolt M8×25	25	2.55	18.5	
36	36 O-ring seal 19.4×2.3				
37	37 vehicle speed sensor assembly				
38	38 screw plug M18×1.5	18	1.8	13	
39	39 O-ring seal 16.4×2.5				
40	40 O-ring seal 13×1.5				
41	41 Screw plug M14×1.5×11	18	1.8	13	
42	42 Front axle box				SS
43	43 Needle roller bearing HK152112				0
44	44 Deep groove ball bearing 6007				O
45	45 round nut M64×1.5	70	6.8	49	L
46	46 O-ring seal 26×2.7				
47	47 Oil seal 48×65×9				G
48	Retaining ring for 48 holes22				
49	49 Front axle universal joint fork				
50	50 flat pad φ14.5×φ35.2×4				
51	51 Hexagonal flange bolt M14×1.5×30	105	10.5	76	L
52	52 universal joint fork assembly				
53	53 450 front axle assembly (without ABS/JN)				

G: Use grease suitable for oil seals and O-rings

L: Use thread glue

O: Use gear oil (AGL 80W/90/GL-5 grade)

SS: Use silicone sealant

R: Accessories

LH: left-hand thread

REAR AXLE WITH DIFFERENTIAL EXPLOSION DIAGRAM

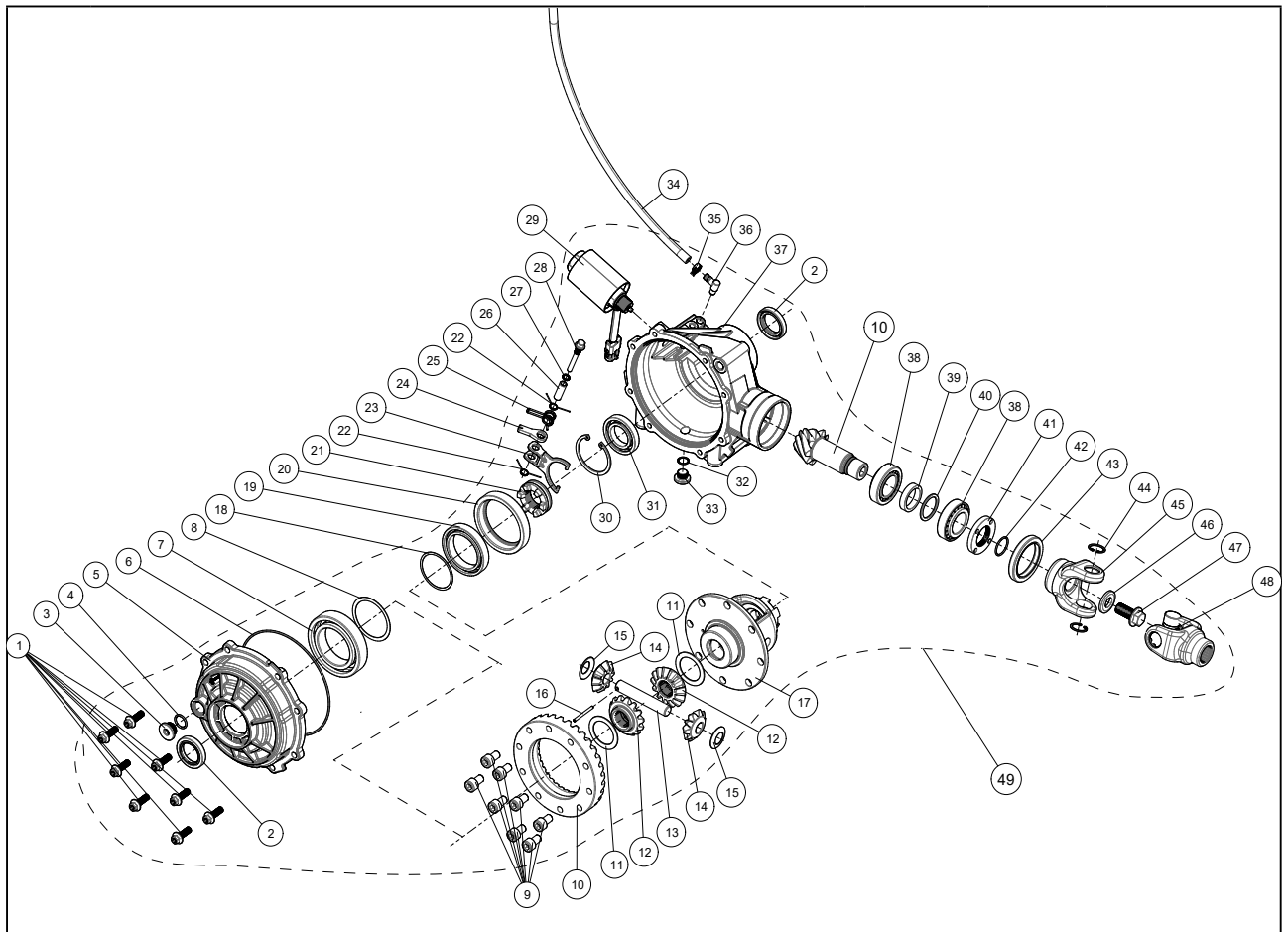

No.	Fastener	Torque			Remarks
		N·m	kgf·m	ft·lb	
1	Hexagonal flange bolt M8×25	25	2.55	18.5	L
2	oil seal 30×45×6.5				G
3	screw plug M18×1.5	18	1.8	13	
4	O-ring seal 16.4×2.5				O
5	Rear axle box cover				
6	O-ring seal φ153×φ2.5				O
7	Deep groove ball bearing 6011				O
8	Adjusting shim φ55×φ65× (0.7, 0.6, 0.5)				
9	Hexagon socket head screw M10×1.25×16	45	4.5	33	L
10	Master-driven bevel gear combination (450 differential speed)				
11	Side bevel gear gasket				
12	half shaft bevel gear				O
13	Planetary gear shaft				O
14	planetary gears				
15	bowl gasket				O
16	elastic cylindrical pin 4×35				
17	differential housing				
18	Adjusting shim φ50×φ55× (0.7, 0.6, 0.5)				
19	Deep groove ball bearing 61910				O
20	bearing ring				
21	clutch transmission claw				

No.	Fastener	Torque			Remarks
		N·m	kgf·m	ft·lb	
22	return spring				
23	shift fork				
24	support frame				
25	U-shaped spring				
26	shift fork bushing				
27	Shift fork cylindrical pin sealing ring				
28	shift fork cylindrical pin				
29	Solenoid valve assembly				
30	Retaining ring for 30 holes55				
31	Deep groove ball bearing 16006				O
32	O-ring seal 13×1.5				O
33	screw plug M14×1.5×11	18	1.8	13	
34	snorkel				
35	Steel belt elastic hose clamp 11				
36	right angle breathing joint				
37	Rear axle box				SS
38	Tapered roller bearing 32006				O
39	spacer				
40	Rear axle driving gear spacer				
41	Threaded sleeve M30×1.5	70	6.8	49	L
42	O-ring seal φ1.9×φ23.5				
43	Oil seal 48×65×9				G
44	Retaining ring for 44 holes 22				
45	universal joint fork				
46	flat pad φ14.5×φ35.2×4				
47	Hexagonal flange bolt M14×1.5×30	105	10.5	76	L
48	universal joint small fork assembly				
49	450 differential rear axle assembly (without ABS/JN)				

G: Use grease suitable for oil seals and O-rings

L: Use thread glue

O: Use gear oil (AGL 80W/90/GL-5 grade)

SS: Use silicone sealant

R: Accessories

LH: left-hand thread

DIAGRAM OF REAR AXLE EXPLOSION WITHOUT DIFFERENTIAL

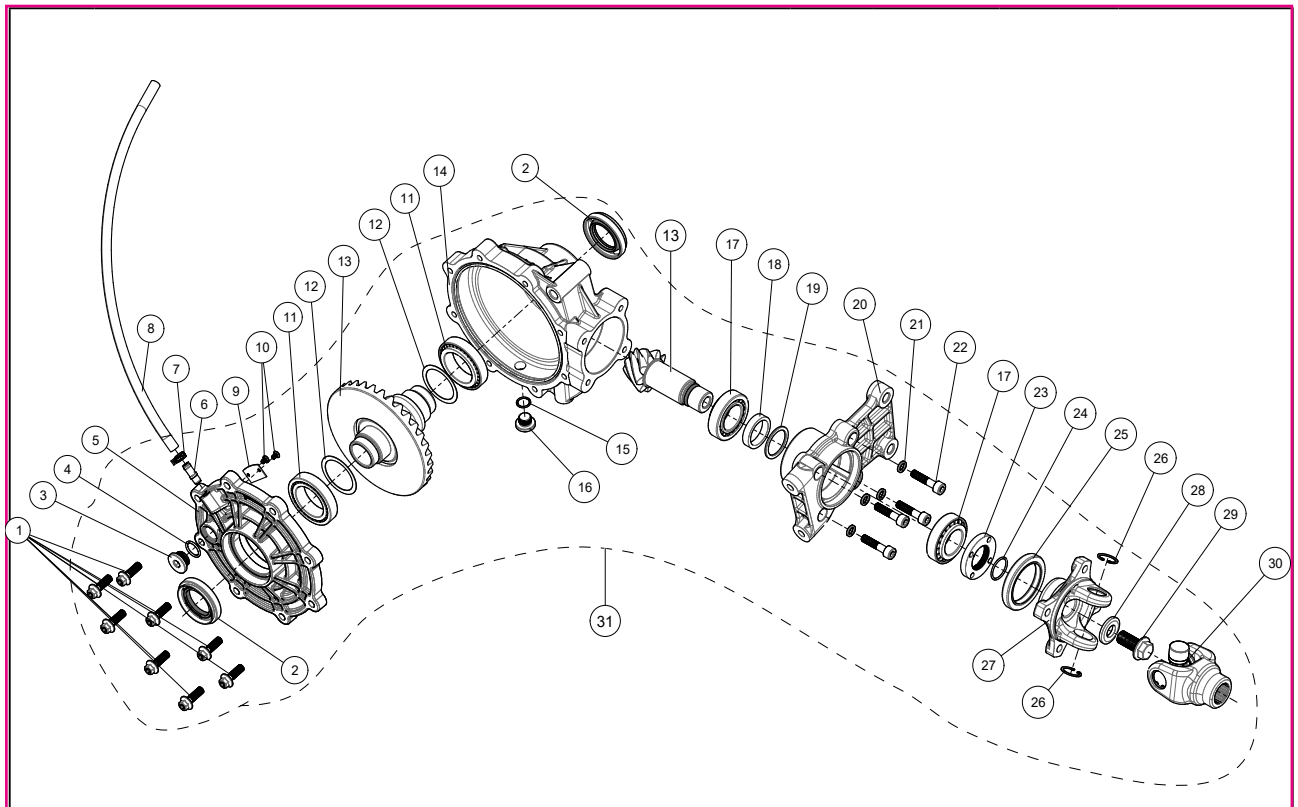

No.	Fastener	Torque			Remarks
		N·m	kgf·m	ft·lb	
1	Hexagonal flange bolt M8×25	25	2.55	18.5	L
2	oil seal 35×56×8				G
3	screw plug M18×1.5	18	1.8	13	
4	O-ring seal 16.4×2.5				O
5	Rear axle box cover				
6	Breather pipe connector				
7	Steel belt elastic hose clamp 11				
8	snorkel				
9	cover				
10	Hexagon socket thin head screws M4×6	1.3	0.12	0.9	L
11	Tapered roller bearing 32908				O
12	Adjusting shim φ40×φ50× (0.7, 0.6, 0.5)				
13	Master and driven bevel gear combination (450 no difference)				
14	Rear axle box				
15	O-ring seal 13×1.5				O
16	screw plug M14×1.5×11	18	1.8	13	
17	Tapered roller bearing 32006				O
18	spacers				
19	Rear axle driving gear spacer				
20	Disc brake fixing bracket				
21	Elastic washer φ8				

No.	Fastener	Torque			Remarks
		N·m	kgf·m	ft·lb	
22	Hexagon socket head screw M8×35 (black zinc)				
23	thread sleeve M30×1.5	70	6.8	49	L
24	O-ring seal $\phi 1.9 \times \phi 23.5$				O
25	oil seal 48×65×9				G
26	hole retaining ring 22				
27	universal joint fork (disc brake disc)				
28	flat pad $\phi 14.5 \times \phi 35.2 \times 4$				
29	Hexagonal flange bolt M14×1.5×30	105	10.5	76	L
30	universal joint fork assembly				
31	450 non-differential rear axle assembly (JN, triple disc brake)				

G: Use grease suitable for oil seals and O-rings

L: Use thread glue

O: Use gear oil (AGL 80W/90/GL-5 grade)

SS: Use silicone sealant

R: Accessories

LH: left-hand thread

FRONT AXLE GEAR OIL REPLACEMENT

⚠ WARNING

Operating a vehicle with insufficient or contaminated front axle oil will cause excessive wear of the front axle, resulting in damage to the front axle, which may cause an accident and cause injury.

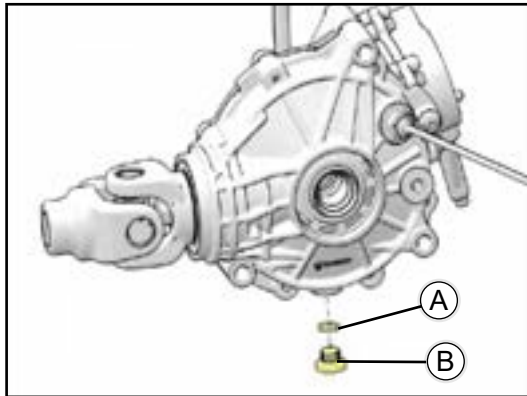
**DRAIN FRONT AXLE OIL**

◆ Disassembly

【A】 O-ring seal 13.8×2.5

【B】 Screw plug M14×1.5×11

◆ Tools: 6mm hex wrench.

- ◆ Unscrew [B] counterclockwise, remove [A] and [B], let the front axle oil flow out, and keep it for 10 minutes. Then put [A] on the bottom of the thread of [B], tighten it clockwise, and wipe away the surrounding oil. Waste oil should be poured into special containers to avoid polluting the environment.

Tightening torque of screw plug M14 assembly

18N·m (1.8kgf·m, 13ft·lb)

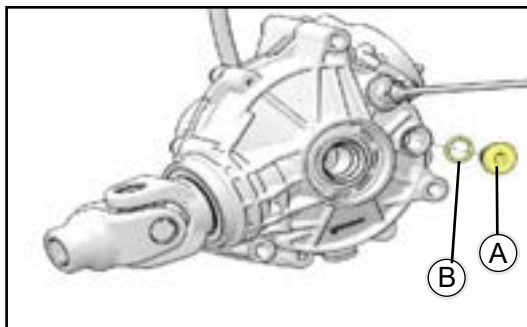
**ADD FRONT AXLE OIL**

◆ Disassembly

【A】 Screw plug M18×1.5

【B】 O-ring seal 16.4×2.5

◆ Tools: 6mm Allen wrench

- ◆ Unscrew [A] counterclockwise, remove [A] and [B] and add gear oil. Put [B] on the bottom of the thread of [A]. Tighten [A] and wipe the surrounding oil clean.

M18 screw plug tightening torque

18N·m (1.8kgf·m, 13ft·lb)

⚠ CAUTION

During installation, check whether the O-ring is intact and not twisted. If the O-ring is damaged, it will cause front axle oil to leak, which may lead to abnormal wear of the internal parts of the front axle or even damage to the front axle. Please replace the O-ring with a new one in time.

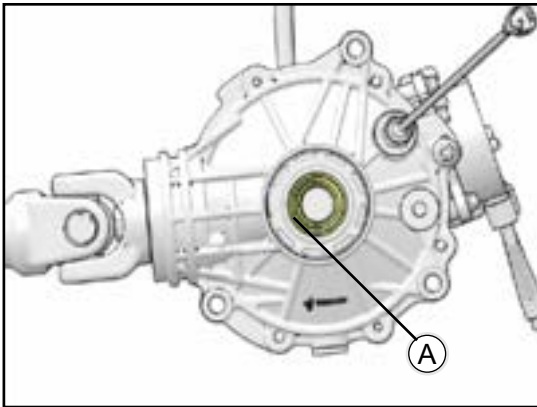

DISASSEMBLE AND REPLACE OIL SEAL

- ◆ Disassembly
- 【A】 Oil seal 24×38×8
- ◆ Tools: Slotted screwdriver, oil seal 24×38×8 tooling
- ◆ Use a flat-blade screwdriver to remove [A], clean the oil stains on the casing, and then use tooling to replace the new [A] in place. As shown in the picture, the oil seals on both sides must be inspected and replaced.

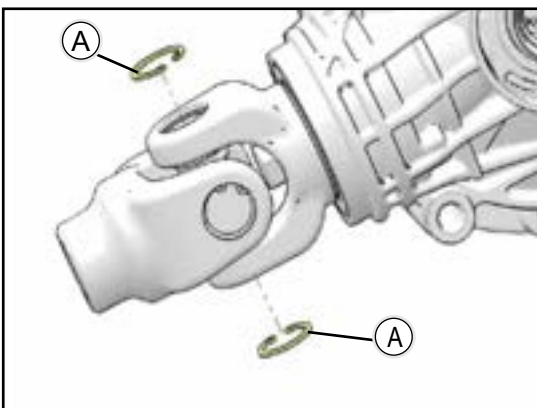
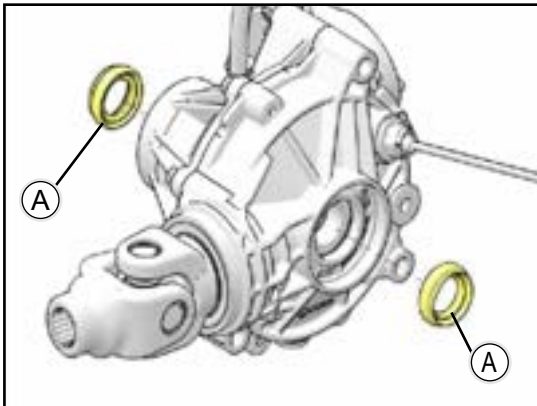

DISASSEMBLE THE CROSS JOINT

- ◆ Disassembly
- 【A】 Retaining ring for hole 22
- ◆ Tools: Internal circlip pliers
- ◆ Use inner circlip pliers to remove the two locations [A] shown in the picture

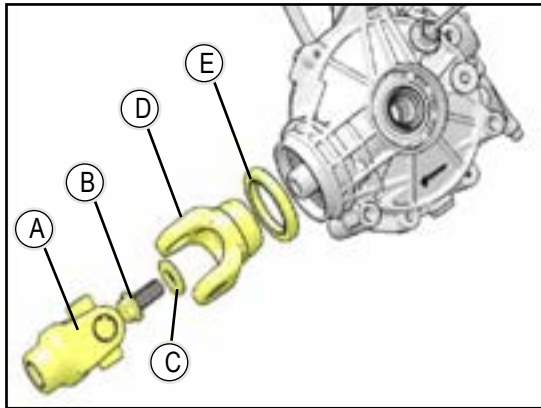

DISASSEMBLE AND REPLACE OIL SEAL

◆ Disassembly

- 【A】 Universal joint fork assembly
- 【B】 Hexagonal flange bolt M14×1.5×30
- 【C】 Flat pad $\phi 14.5 \times \phi 35.2 \times 4$
- 【D】 Front axle universal joint fork
- 【E】 Oil seal 48×65×9

◆ Tools: 18mm socket, slotted screwdriver, oil seal 48×65×9 tooling

◆ After removing [A], unscrew the bolt [B] counterclockwise, remove [C], [D], and [E], wipe the oil stains around the casing, replace the new part [E], and install [D], [C], tighten [B] clockwise, and install [A] in place

Hexagonal flange bolt M14×1.5×30
tightening torque

105N·m (10.5kgf·m, 76ft·lb)

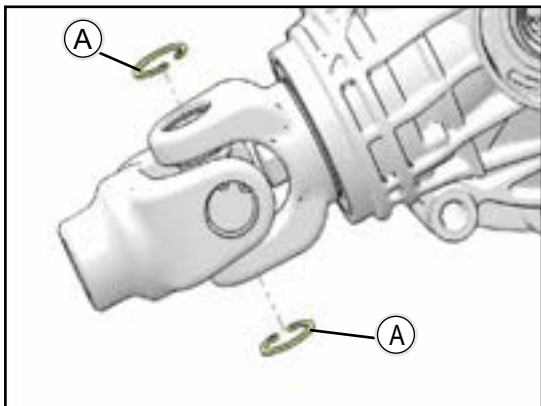

INSTALL THE CROSS JOINT

◆ Disassembly

- 【A】 Retaining ring for hole 22
- ◆ Tools: Internal circlip pliers
- ◆ Use inner circlip pliers to install the two locations shown in the picture [A]

DIFFERENTIAL REAR AXLE GEAR OIL REPLACEMENT

⚠ WARNING

Running a vehicle with insufficient or contaminated transmission fluid can cause excessive transmission wear, resulting in transmission damage that could cause an accident and result in injury.

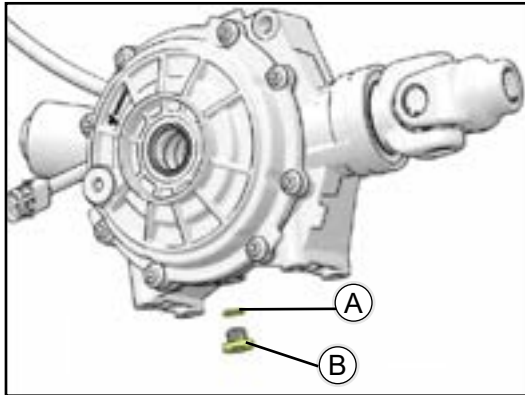
**DRAIN DIFFERENTIAL REAR AXLE OIL**

- ◆ Disassembly
- 【A】 O-ring seal 13.8×2.5
- 【B】 Screw plug M14 assembly
- ◆ Tools: 6mm hex wrench.
- ◆ Unscrew [B] counterclockwise, remove [A] and [B], let the transmission oil flow out, and keep it for 10 minutes. Then put [A] on the bottom of the thread of [B], tighten it clockwise, and wipe away the surrounding oil. Waste oil should be poured into special containers to avoid polluting the environment.

Tightening torque of screw plug M14 assembly

18N·m (1.8kgf·m, 13ft·lb)

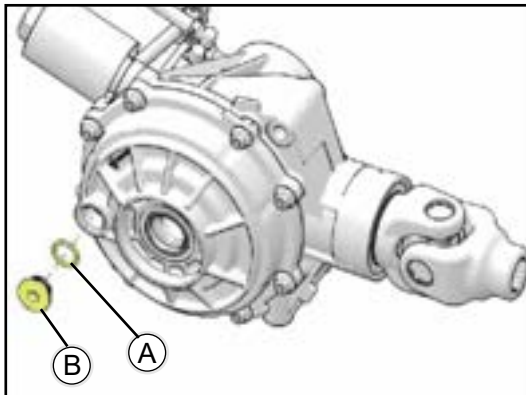
**ADD DIFFERENTIAL REAR AXLE OIL**

- ◆ Disassembly
- 【A】 O-ring seal 16.4×2.5
- 【B】 Screw plug M18×1.5
- ◆ Unscrew the oil dipstick
- ◆ Unscrew [B] counterclockwise, remove [B] and [A] and add new transmission oil. Put [A] on the bottom of the thread of [B]. Tighten [B] and wipe the surrounding oil clean.

M18 screw plug tightening torque

18N·m (1.8kgf·m, 13ft·lb)

⚠ CAUTION

During installation, check whether the O-ring is intact and not twisted. If the O-ring is damaged, it will cause transmission oil to leak, which may lead to abnormal wear of internal parts of the transmission or even damage to the transmission. Please replace the O-ring with a new one in time.

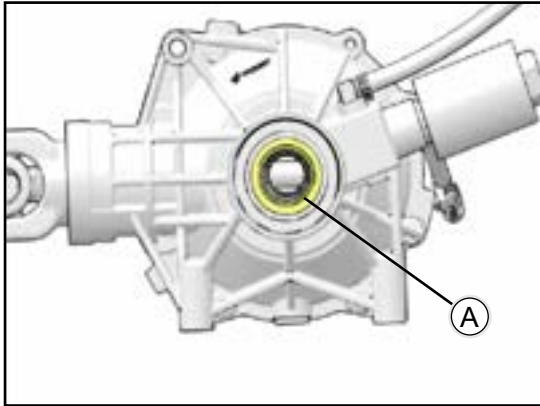

DISASSEMBLE AND REPLACE OIL SEAL

- ◆ Disassembly

【A】 Oil seal 30×45×6.5

- ◆ Tools: Slotted screwdriver, oil seal 30×45×6.5 tooling
- ◆ Use a flat-blade screwdriver to remove [A], clean the oil stains on the casing, and then use tooling to replace the new [A] in place. As shown in the picture, the oil seals on both sides must be inspected and replaced.

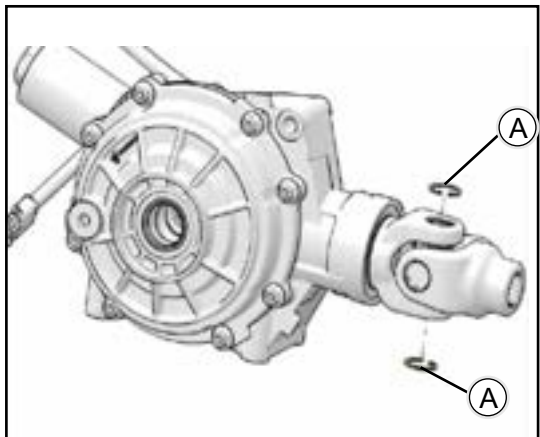
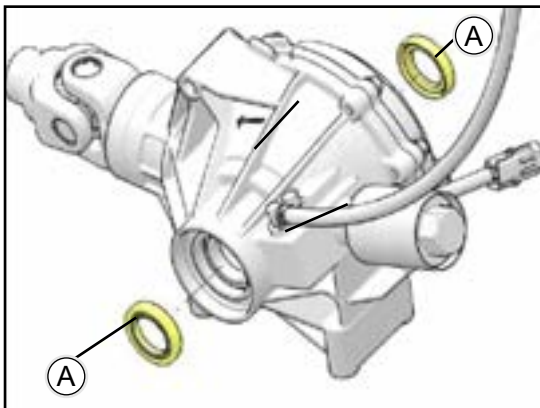

DISASSEMBLE THE CROSS JOINT

- ◆ Disassembly

【A】 Retaining ring for hole 22

- ◆ Tools: Internal circlip pliers
- ◆ Use inner circlip pliers to remove the two locations [A] shown in the picture

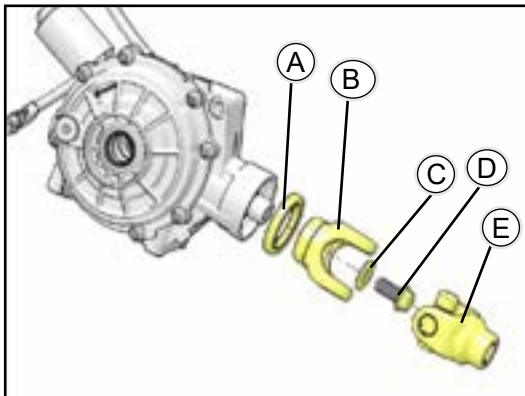

DISASSEMBLE AND REPLACE OIL SEAL

◆ Disassembly

【A】 Oil seal 48×65×9

【B】 Universal joint fork

【C】 Flat pad $\phi 14.5 \times \phi 35.2 \times 4$

【D】 Hexagonal flange bolt M14×1.5×30

【E】 Universal joint fork assembly

◆ Tools: 18mm socket, slotted screwdriver, oil seal 48×65×9 tooling

◆ After removing [E], unscrew the bolt [D] counterclockwise, remove [C], [B], and [A], wipe off the oil stains around the casing, replace the new part [A], and install [B], [C], tighten [D] clockwise, and install [E] in place

Hexagonal flange bolt M14×1.5×30
tightening torque

105N·m (10.5kgf·m, 76ft·lb)

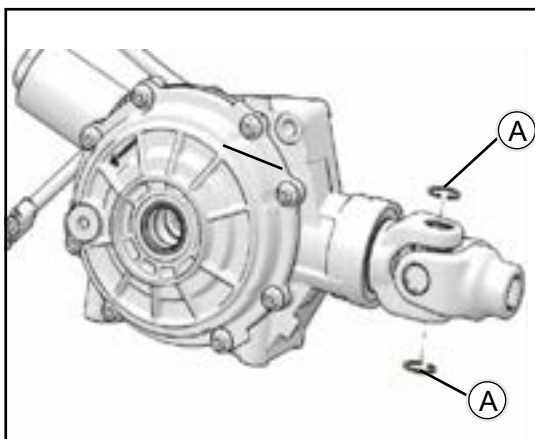

INSTALL THE CROSS JOINT

◆ Disassembly

【A】 Retaining ring for hole 22

◆ Tools: Internal circlip pliers

◆ Use inner circlip pliers to install the two locations shown in the picture [A]

NON-DIFFERENTIAL REAR AXLE GEAR OIL REPLACEMENT

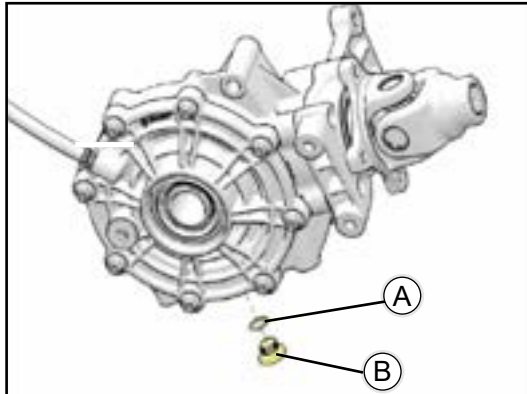
**⚠ WARNING**

Operating a vehicle with insufficient or contaminated transmission fluid can cause excessive wear and tear on the transmission, leading to transmission damage and possible accidents and injuries.

DRAIN DIFFERENTIAL REAR AXLE OIL

- ◆ Disassembly
- 【A】 O-ring seal 13.8×2.5
- 【B】 Screw plug M14 assembly
- ◆ Tools: 6mm hex wrench.
- ◆ Unscrew [B] counterclockwise, remove [A] and [B], let the transmission oil flow out, and keep it for 10 minutes. Then put [A] on the bottom of the thread of [B], tighten it clockwise, and wipe away the surrounding oil. Waste oil should be poured into special containers to avoid polluting the environment.

Tightening torque of screw plug M14 assembly

18N·m (1.8kgf·m, 13ft·lb)

ADD DIFFERENTIAL REAR AXLE OIL

- ◆ Disassembly
- 【A】 O-ring seal 16.4×2.5
- 【B】 Screw plug M18×1.5
- ◆ Unscrew the oil dipstick
- ◆ Unscrew [A] counterclockwise, remove [A] and [B] and add new transmission oil. Put [B] on the bottom of the thread of [A]. Tighten [A] and wipe the surrounding oil clean.

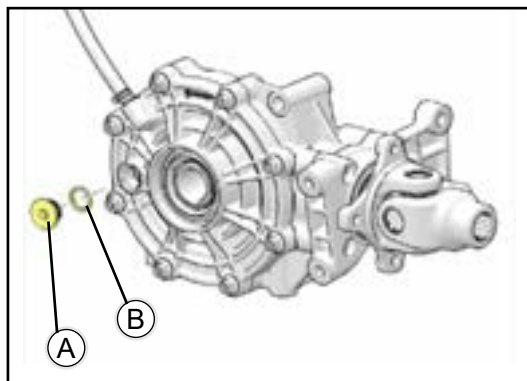

M18 screw plug tightening torque

18N·m (1.8kgf·m, 13ft·lb)

⚠ CAUTION

During installation, check whether the O-ring is intact and not twisted. If the O-ring is damaged, it will cause transmission oil to leak, which may lead to abnormal wear of internal parts of the transmission or even damage to the transmission. Please replace the O-ring with a new one in time.

OIL SEAL REPLACEMENT AND ASSEMBLY

DISASSEMBLE AND REPLACE OIL SEAL

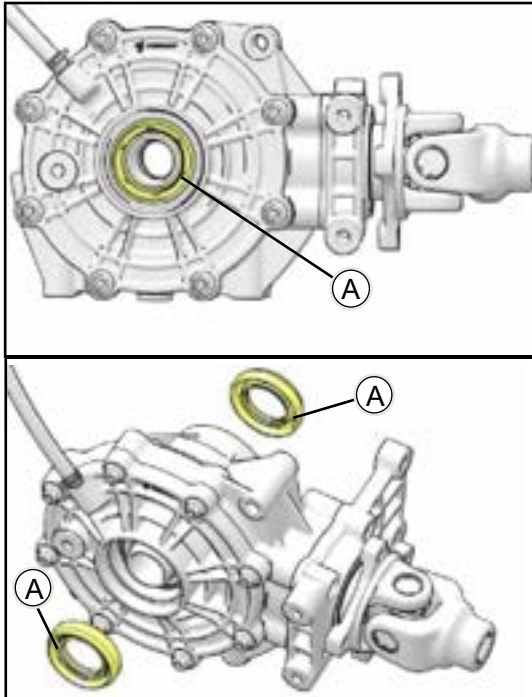

- ◆ Disassembly

【A】 Oil seal 35×56×8

- ◆ Tools: Slotted screwdriver, oil seal 35×56×8 tooling
- ◆ Use a flat-blade screwdriver to remove [A], clean the oil stains on the casing, and then use tooling to replace the new [A] in place. As shown in the picture, the oil seals on both sides must be inspected and replaced.

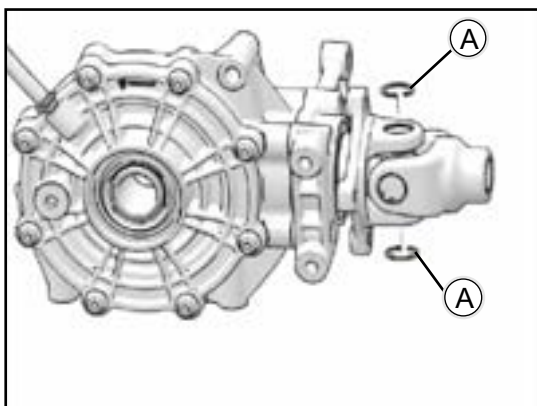

DISASSEMBLE THE CROSS JOINT

- ◆ Disassembly

【A】 Retaining ring for hole 22

- ◆ Tools: Internal circlip pliers
- ◆ Use inner circlip pliers to remove the two locations [A] shown in the picture

DISASSEMBLE AND REPLACE OIL SEAL

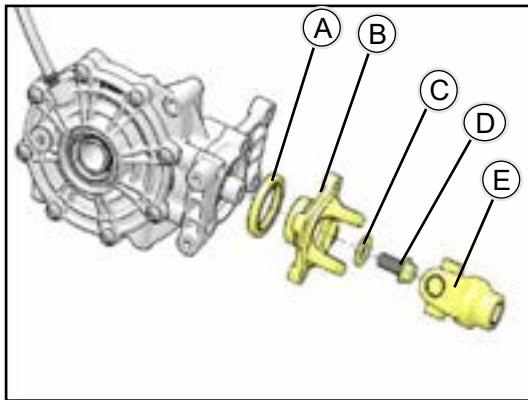

◆ Disassembly

【A】 Oil seal 48×65×9

【B】 Universal joint fork (disc brake disc)

【C】 Flat pad $\phi 14.5 \times \phi 35.2 \times 4$

【D】 Hexagonal flange bolt M14×1.5×30

【E】 Universal joint fork assembly

◆ Tools: 18mm socket, slotted screwdriver, oil seal 48×65×9 tooling

◆ After removing [E], unscrew the bolt [D] counterclockwise, remove [C], [B], and [A], wipe off the oil stains around the casing, replace the new part [A], and install [B], [C], tighten [D] clockwise, and install [E] in place

Hexagonal flange bolt M14×1.5×30
tightening torque

105N·m (10.5kgf·m, 76ft·lb)

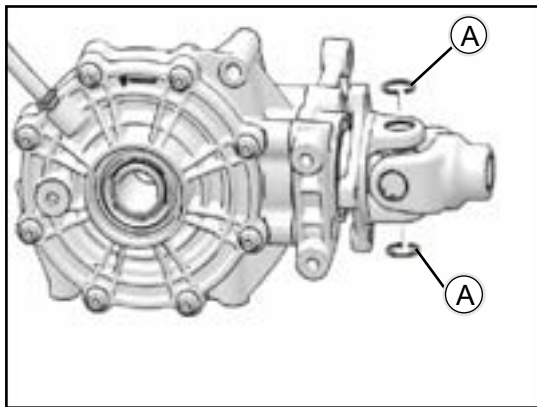

INSTALL THE CROSS JOINT

◆ Disassembly

【A】 Retaining ring for hole 22

◆ Tools: Internal circlip pliers

◆ Use inner circlip pliers to install the two locations shown in the picture [A]

FUEL SYSTEM

FUEL TANK EXPLODED VIEW OF FUEL SYSTEM4-2

FUEL TANK REMOVAL/INSTALLATION4-3

 DISASSEMBLY4-3

 INSTALLATION4-3

FUEL FILTER REMOVAL / INSTALLATION4-4

 REMOVAL4-4

 INSTALLATION4-5

CARBON CANISTER ASSEMBLY REMOVAL / INSTALLATION4-6

 DISASSEMBLY4-6

 INSTALLATION4-7

FUEL TANK EXPLODED VIEW OF FUEL SYSTEM

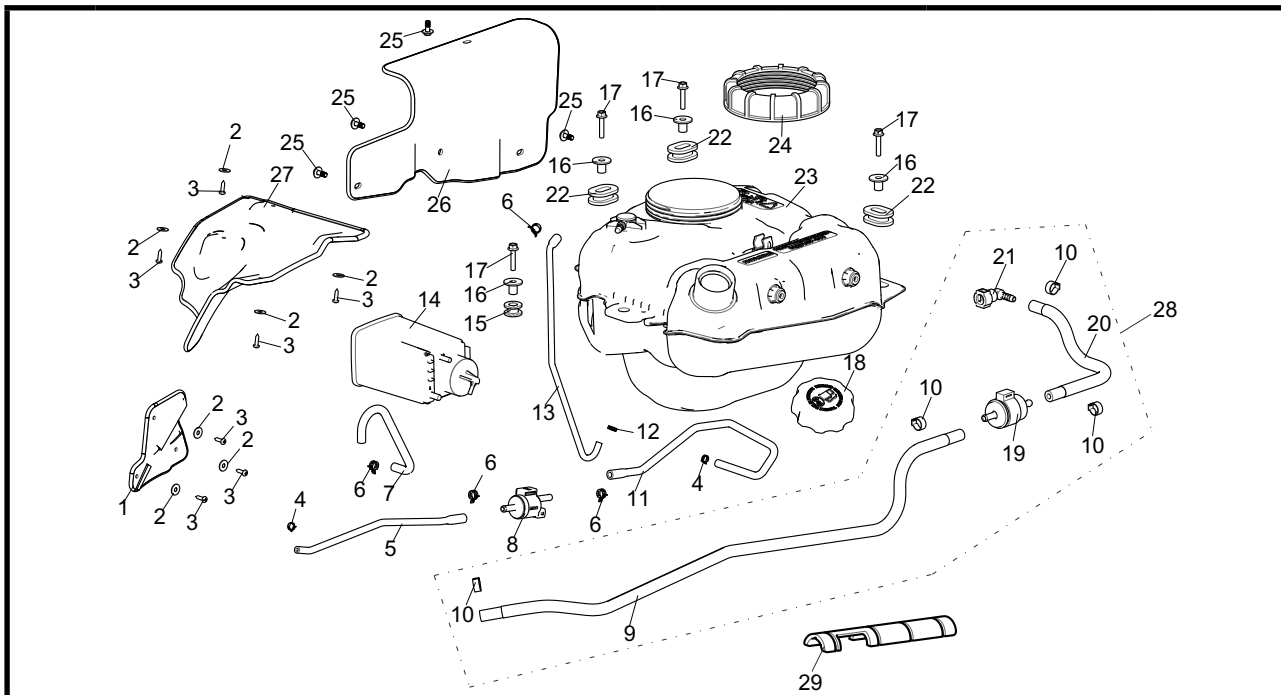

No.	Fastener	Torque			Remarks
		N·m	kgf·m	ft·lb	
1	Center shield front heat shield				
2	Large Gasket A Class 5				
3	Cross recessed pan head tapping screws ST4.2×16				
4	Steel band elastic hose clamp 9				
5	Throttle de-attachment tube				
6	Steel band elastic hose clamp 11				
7	Carbon Canister Vent Hose				
8	Carbon canister solenoid valve				
9	Injector end high pressure fuel line				
10	Single lug stepless clamp 16.5				
11	Carbon canister desorption tube				
12	Steel band elastic hose clamp hoop 7				
13	suction tube				
14	Carbon Canister Assembly				
15	Fuel tank mounted round rubber gasket				
16	Tank mounted T-bushings				
17	Hexagonal flange face bolts M6×30	8~12	0.8~1.2	69~103.6 IN·LB	
18	Fuel tank cap assembly				
19	Fuel filter assembly				
20	Oil pump end high-pressure oil hose				
21	9.49 Quick connect plug (90 degrees)				
22	Fuel tank mounting I-beam rubber boot				
23	Fuel tank assembly				
24	Oil pump mounting screw cap	75	7.5	55	
25	Combination bolt M6×16	8~12	0.8~1.2	69~103.6 IN·LB	
26	Fuel tank heat shield				
27	Rear fender heat shield				
28	High pressure fuel line assembly				
29	cushioning rubber boot				

FUEL TANK REMOVAL/INSTALLATION

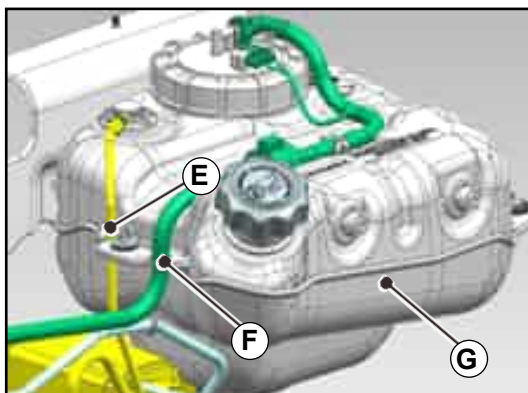
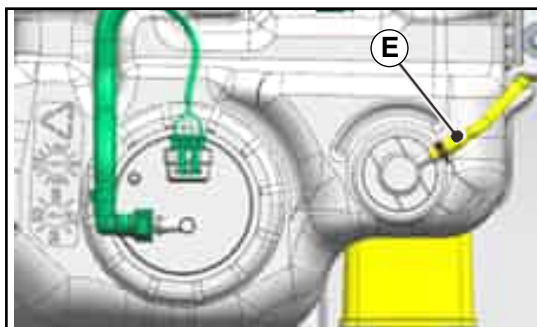
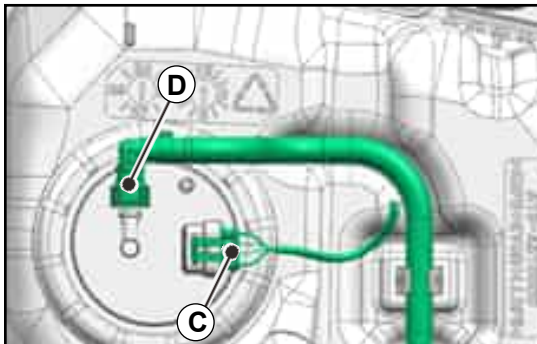
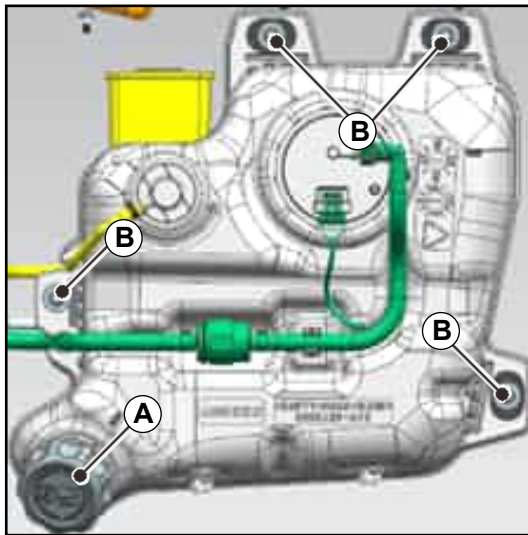
**⚠ WARNING**

- ◆ Whenever the gasoline line is removed, the battery connection must be disconnected to prevent the accidental startup of the fuel pump.
- ◆ Whenever any repairs or inspections are made to the fuel system, there is a possibility that a fuel leaks may occur. No welding, smoke, open flames, etc., should be allowed in the area.

DISASSEMBLY

- 【A】** Fuel tank cover
- 【B】** Fuel tank mounting bolts M6×30
- 【C】** Fuel pump cable plug
- 【D】** High pressure fuel line plug
- 【E】** Breathing valve vent pipe/carbon canister adsorption pipe
- 【F】** High-pressure fuel line
- 【G】** Fuel tank assembly

- ◆ Remove the fuel tank cover **【A】** ;
- ◆ Remove the body plastic parts and the seat and rear shelf support assembly (see the body
- ◆ Remove the body plastic parts and the seat and rear rack support assembly (see the body section for details);
- ◆ Disconnect the battery cable;
- ◆ Disconnect the battery cable;
- ◆ Disconnect the fuel pump cable plug **【C】** and the high pressure fuel line plug **【D】** ;
- ◆ Disconnect the fuel pump cable plug **【C】** and the high pressure fuel line plug **【D】** ;
- ◆ Remove the breather valve vent tube/carbon canister adsorption tube **【E】** .
- ◆ Remove the high pressure fuel line **【F】** .
- ◆ Remove the 4 fuel tank mounting bolts **【B】** with appropriate tools;
- ◆ Remove the fuel tank **【G】** ;

⚠ CAUTION

Fuel leakage may occur during the removal of any fuel system components phenomenon, wipe off the residual oil with a cloth.

INSTALLATION

- ◆ When assembling, assemble in the reverse order of disassembly;
- ◆ When assembling the high-pressure fuel pipe plug, make sure it is assembled correctly and reliably.

FUEL FILTER REMOVAL / INSTALLATION

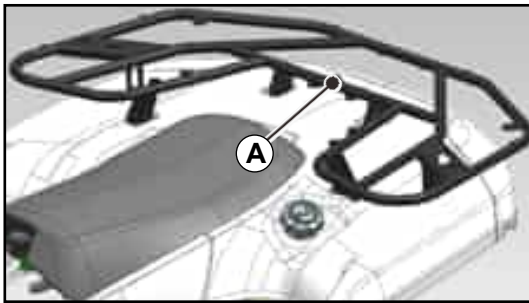

⚠ WARNING

- ◆ Whenever the gasoline line is removed, the battery must be disconnected to prevent the accidental startup of the fuel pump.
- ◆ Whenever any repairs or inspections are made to the fuel system, fuel leaks may occur. No welding, smoke, open flames, etc., should be allowed in the area. Welding, smoke, open flames, etc. must not be allowed in this area.

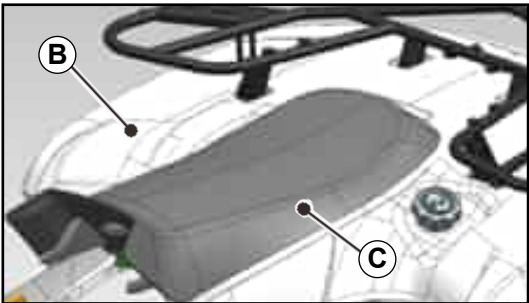

REMOVAL

Fuel filter under rear fender, on rear rack support assembly

- 【A】 Rear rack weldment assembly
- 【B】 Rear fender
- 【C】 Seat cushion assembly
- 【D】 Rear rack support assembly
- 【E】 Fuel filter assembly
- 【F】 Single lug stepless clamp 16.5

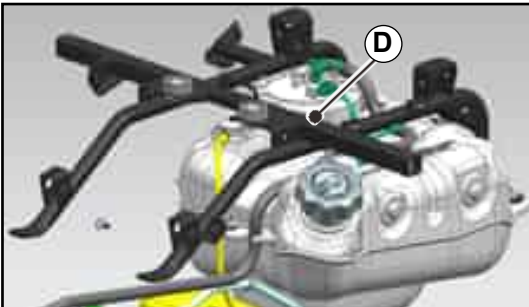

- ◆ Remove the rear shelf welding assembly 【A】 (see body section for details);
- ◆ Remove the seat cushion assembly 【C】 ;
- ◆ Remove the rear fender 【B】 (see body section for details).
- ◆ Remove the rear shelf support assembly 【D】 (see body section for details)
- ◆ Remove the fuel filter by removing the clamps with the appropriate tool 【F】 ; remove the fuel filter 【E】 .
- ◆ Remove the fuel filter 【E】 ;

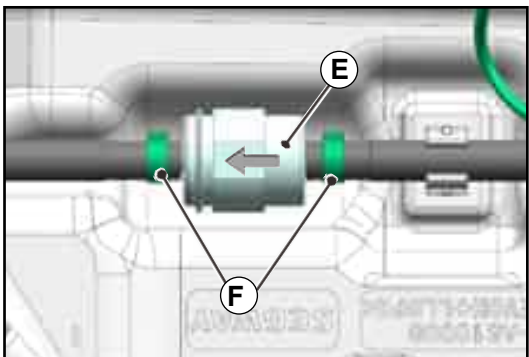

⚠ CAUTION

Fuel leakage may occur during the removal of any fuel system components phenomenon, wipe off the residual oil with a cloth.

FUEL FILTER REMOVAL / INSTALLATION**INSTALLATION**

【F】 Single ear stepless clamp bracket 16.5

【E】 Fuel filter

- ◆ When assembling the fuel filter, make sure that the arrow is pointing (as shown in the left figure) in the fuel
- ◆ When assembling the fuel filter, make sure the arrow is pointing toward the fuel filter (as shown on the left).
- ◆ Replace the clamp 【F】 with a new one, and tighten it with a specialized tool;
- ◆ To assemble the remaining parts, reverse the order of disassembly;

⚠ 注意

When replacing or assembling the fuel filter, please carefully check whether the fuel pipe is intact or not to avoid fuel leakage.

to avoid fuel leakage, and then use professional tools to tighten the clamp after confirming that there is no error.

After confirming that the fuel hose is correct, use professional tools to tighten the clamp.

CARBON CANISTER ASSEMBLY REMOVAL / INSTALLATION

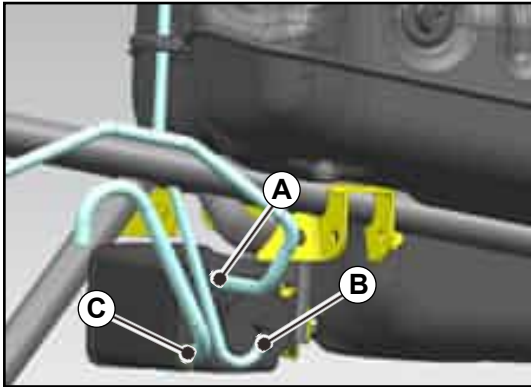

⚠ WARNING

- ◆ Whenever the gasoline line is removed, the battery must be disconnected to prevent the accidental startup of the fuel pump.
- ◆ Whenever any repairs or inspections are made to the fuel system, fuel leaks may occur. No welding, smoke, open flames, etc., should be allowed in the area. Welding, smoke, open flames, etc. must not be allowed in this area.

DISASSEMBLY

Carbon canister assembly is mounted on the lower left front of the fuel tank, upper rear axle

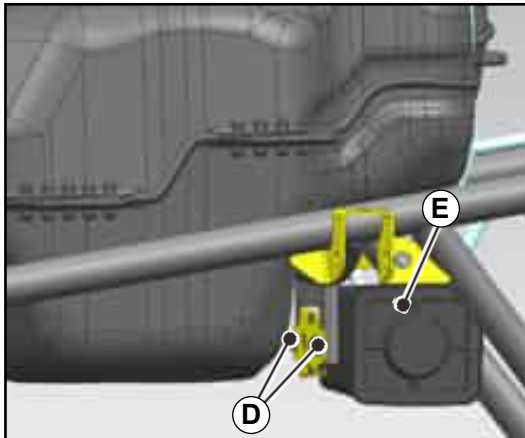

- 【A】 Steel belt type elastic hose clamp 9
- 【B】 Steel belt type elastic hose clamp 7
- 【C】 Steel belt type elastic hose clamp 11
- 【D】 Carbon canister mounting bolt M6×12
- 【E】 Carbon canister assembly
- 【F】 Carbon canister desorption tube
- 【G】 Adsorption tube
- 【H】 Carbon canister vent pipe

- ◆ Remove the rear fender (see body section for details);
- ◆ Remove the clamp 【A】 with the appropriate tool and pull out the carbon canister detachment tube
- ◆ Remove the clamp 【A】 and pull out the carbon canister disconnecting tube with the appropriate tool;
- ◆ Remove the clamp 【B】 and pull out the adsorption tube 【F】 with an appropriate tool.
- ◆ Remove the clamp 【C】 and pull out the carbon canister vent tube 【H】 with the appropriate tool.
- ◆ Remove the bolts 【D】 with the appropriate tool and take out the carbon canister assembly 【E】 ;

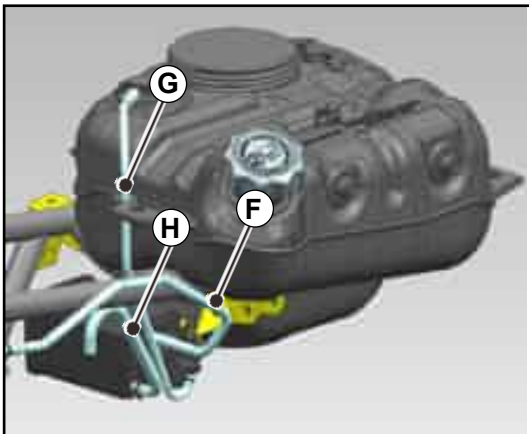

⚠ CAUTION

Fuel leakage may occur during the removal of any fuel system components phenomenon, wipe off the residual oil with a cloth.

CARBON CANISTER ASSEMBLY REMOVAL / INSTALLATION**INSTALLATION**

When assembling, reverse the order of disassembly;
When assembling tubing and clamps, make sure they are assembled correctly and reliably.

⚠ CAUTION

When replacing or assembling the carbon canister assembly, please carefully check whether the oil pipe is intact.

To avoid oil and gas leakage, after confirming that there is no error, then use professional tools to tighten the clamp.

After confirming the correctness, then use professional tools to clamp the clamp.

COOLING SYSTEM

EXPLODED VIEW OF COOLING SYSTEM6-2

COOLANT FLOW6-3

TECHNICAL PARAMETER6-5

 COOLING SYSTEM PRESSURE TEST6-6

 RADIATOR CAP PRESSURE TEST6-7

 RADIATOR CHECK.....6-8

 RADIATOR REMOVAL / INSTALLATION6-8

 RADIATOR FAN REMOVAL/INSTALLATION6-9

EXPLODED VIEW OF COOLING SYSTEM

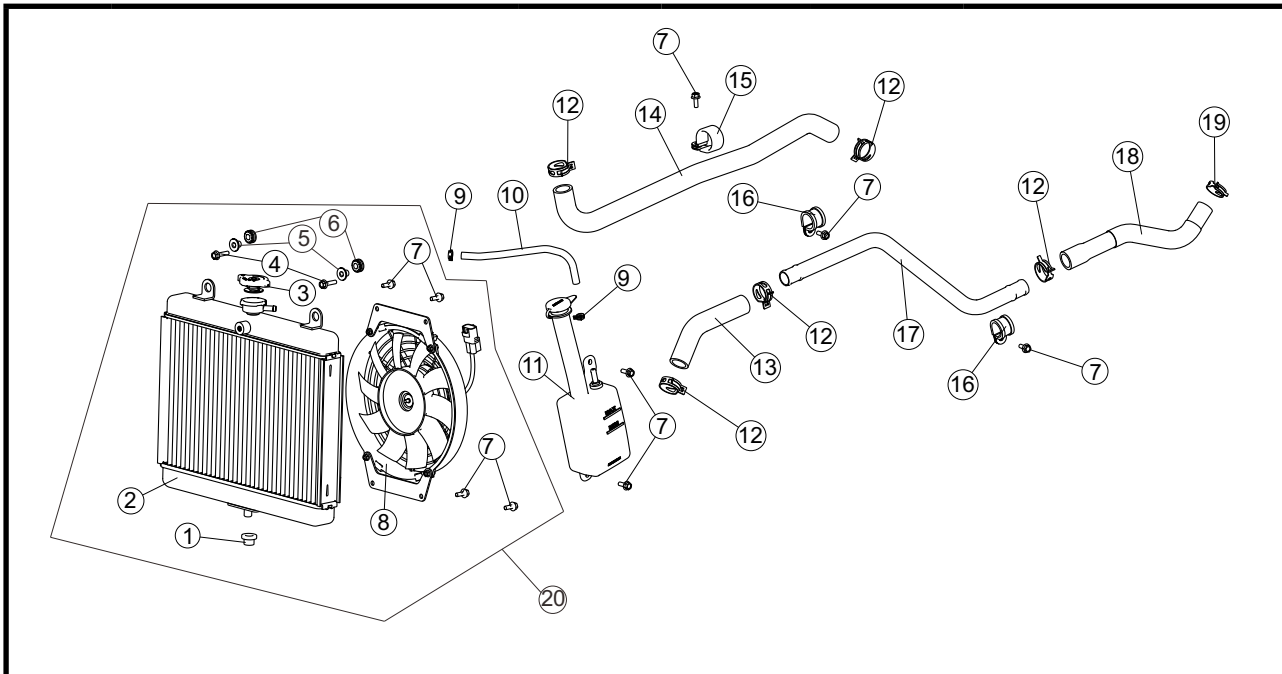

No.	Fastener	Torque			Remarks
		N·m	kgf·m	ft·lb	
1	Buffer rubber				
2	Engine radiator body				
3	Tank lid assy v				
4	Hexagon flange bolt m6×25	8 ~ 12	0.8~1.2	6~9	
5	T-sleeve				
6	I-shaped rubber parts				
7	Bolt m6×16	8 ~ 12	0.8~1.2	6~9	
8	Cooling fan (80w)				
9	Clamp 11				
10	Overflow pipe				
11	Reserve water tank				
12	Clamp, springband 30				
13	Radiator outlet hose				
14	Engine water inlet hose				
15	32 Clamps				
16	25 Strip components				
17	Engine water intake aluminum hose				
18	Engine water inlet hose				
19	Steel belt elastic hose clamp 28				
20	Engine radiator assembly				

COOLANT FLOW

Permanent antifreeze is selected for use as coolant to prevent rust and corrosion in the cooling system. When the engine starts, the water pump turns and the coolant circulates. The thermostat is a wax particle type that opens or closes as the coolant temperature changes. The thermostat constantly changes its valve opening to keep the coolant temperature of the coolant at the proper level. When the coolant temperature falls below 79 to 82°C (174.2 to 179.6°F), the thermostat closes. F), the thermostat closes, so the coolant flow through the vent hole is reduced. When the coolant temperature is below 79 to 82°C (174.2 to 179.6 °F), the thermostat closes, thus restricting the flow of coolant through the vent and allowing the engine to warm up faster. When the coolant temperature exceeds 79 to 82°C (174.2 to 1179.6) °F), the thermostat will open and coolant will flow. When the coolant temperature reaches 88°C (190.4°F), the radiator fan switch opens and the radiator fan operates. When there is not enough airflow (e.g., at low speeds) the the radiator fan draws air through the radiator core. This increases the cooling effect of the radiator. When the temperature is below 83°C (181.4 °F), the fan switch is disconnected and the radiator fan stops working.

In this way, the system controls the engine temperature within a narrow range of engine operation. Even when the engine load varies, engine operating efficiency is maximized

The system is pressurized through the radiator cap to inhibit boiling and the resulting air bubbles that can cause the engine to overheat. As the engine warms up, the coolant in the radiator and water lines expands. Excess coolant flows through the radiator cap and hoses into the reservoir. Conversely, when the engine cools, the coolant in the radiator and water lines contracts and stored coolant flows from the reservoir back to the radiator. The radiator cap has two valves. One is a pressure valve, which maintains pressure in the system when the engine is running. When the pressure exceeds 93 to 123 kPa (0.95 1.25 kgf/cm², 14 to 18 psi), the pressure valve opens and releases pressure to the reservoir. Once the pressure overflows, the valve closes and maintains the pressure at 93 ~ 123kPa (0.95 ~ 1.25kgf/cm², 14 ~ 18psi). When the engine cools, another small valve (vacuum valve) on the cover opens. As the coolant cools, the coolant contracts, creating a vacuum in the system. The vacuum valve opens and allows coolant to enter the radiator from the reservoir.

COOLANT FLOW

Red arrow: Hot coolant

Blue arrow: cold coolant

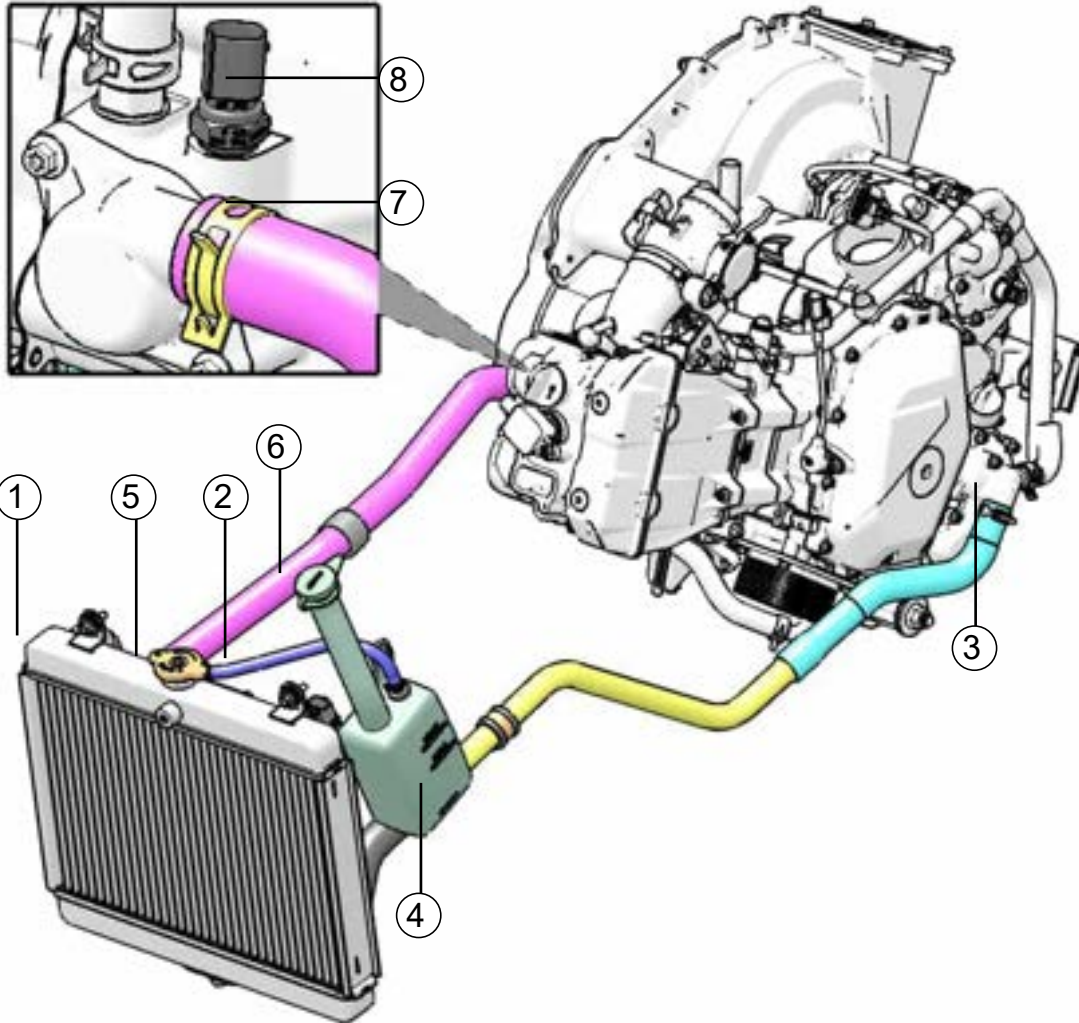

1. Radiator
2. Engine radiator vent pipe
3. Water pump cover
4. Sub-tank
5. Water filler cap assembly
6. Sub-tank cover
7. Thermostat cover
8. Water temperature sensor assembly

TECHNICAL PARAMETER

ITEM	STANDARD	SERVICE LIMIT
Coolant provided during transportation:		
Type	Permanent antifreeze (soft water and glycol for aluminum engines and radiators plus corrosion inhibitors and rust inhibitor chemicals)	- - -
Color	Green	- - -
Mixing ratio	Soft water 50%, cooling water 50%	- - -
Total	3 liters (US qt) (full reservoir level, including radiator and engine)	- - -
Radiator cover		
Pressure relief	93 ~ 123 KPA (0.95 ~ 1.25 KGF /CM ² , 14 ~ 18PSI)	- - -
Thermostat		
Valve opening temperature	79 ~ 82°C (174.2 ~ 179.6°F)	- - -
Valve fully open lift	8~12mm or over 85°C (185°F)	- - -
Coolant filter/valve		
Cooling valve closing temperature (For reference)	83°C (181.4°F) OR OVER 24.5KPA (0.25KGF/CM ² , 3.6 PSI)	- - -

COOLING SYSTEM PRESSURE TEST

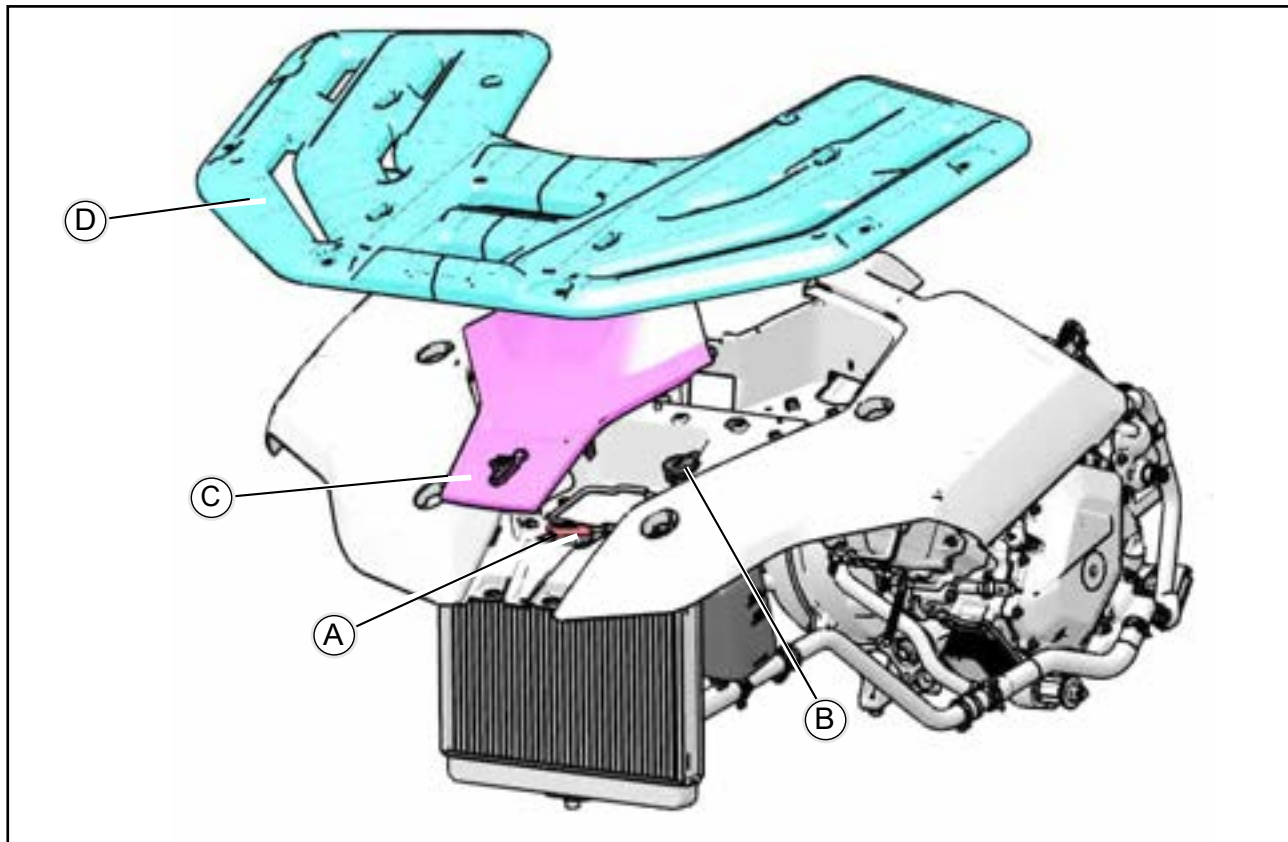

A. Fill port B. Fill port cover C. Front service cover D. Front shelf

- ◆ Remove front shelf D, front access cover C and radiator cap B, then install a cooling system pressure tester on radiator filler port A.

⚠ CAUTION

Wet the cap sealing surface with water or coolant to prevent pressure leakage.

Wet the cap sealing surface with water or coolant to prevent pressure leakage. Slowly pressurize until pressure rises to 123 kPa (1.25 kgf/cm², 18 psi).

⚠ WARNING

Do not exceed the design pressure of the system during the pressure test. The maximum value pressure is 123kPa (1.25kgf/cm² , 18 psi).

- ◆ Observe the pressure gauge for at least 6 seconds.
- ◆ If the pressure remains steady, the system is normal. If pressure drops quickly, check for leaks.

RADIATOR CAP PRESSURE TEST

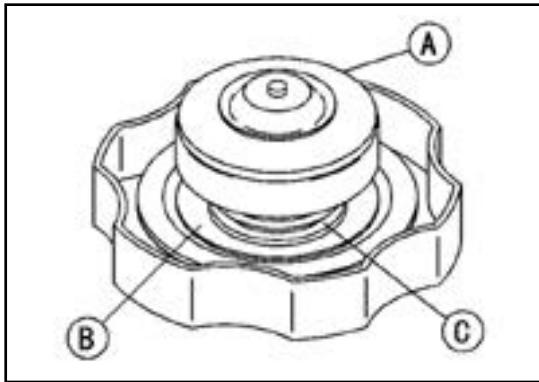

- ◆ Check the condition of the radiator cap top and bottom seals.
- ◆ Replace the radiator cap if either of them appears damaged.

【A】 Bottom seal

【B】 Top seal

【C】 Pressure valve spring

- ◆ Install the radiator bottom seal 【A】 on the cooling system pressure tester 【D】 for testing.
- ◆ Install the radiator bottom seal 【A】 on the cooling system pressure tester 【D】 for testing.

⚠ CAUTION

Wet the radiator cap sealing surface with water or coolant to prevent pressure leakage.

- ◆ Observe the pressure gauge and slowly press the pressure tester to increase the pressure.
- ◆ The radiator cap must open within the safe pressure range and the gauge needle must remain within the specified range for at least 6 seconds.

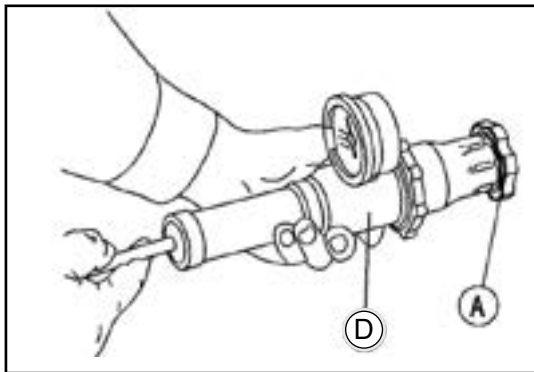

- ◆ Observe the pressure gauge and slowly press the pressure tester to increase the pressure.
- ◆ The radiator cap must open within the safe pressure range and the gauge needle must remain within the specified range for at least 6 seconds.

Radiator cap pressure relief value standard :

93~123kPa (0.95~1.25 kgf /cm², 14~18psi)

⚠ WARNING

Do not exceed the design pressure of the system during the pressure test. The maximum value pressure is 123kPa (1.25kgf/cm², 18psi).

If the radiator valve fails to hold the specified pressure, or the pressure is too high, replace the radiator cap with a new one.

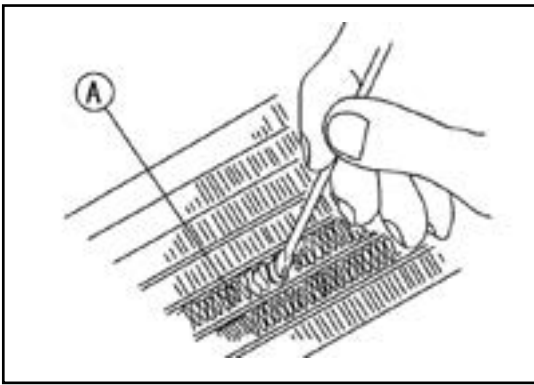

RADIATOR CHECK

- ◆ Check the radiator core.
- ◆ If there is an obstruction to air flow, remove the radiator and clear the obstruction.
- ◆ If the corrugated fins **【A】** are deformed, carefully straighten them.
- ◆ If the air path of the radiator core is blocked more than 20%, but the obstruction cannot be removed or the heat sink cannot repair the deformation, dismantle the radiator and remove the obstruction.

RADIATOR REMOVAL / INSTALLATION

⚠ WARNING

1. The opening and stopping of the radiator fan is controlled by the ECU of the whole vehicle, when the engine head water temperature reaches 90°C, the fan will be opened automatically.

When the cylinder head water temperature reaches 90°C, the fan will automatically turn on; until the cylinder head water temperature drops below 85°C, the radiator fan will automatically stop.

When the cylinder head water temperature drops below 85°C, the radiator fan stops automatically. Do not touch the radiator fan while it is running.

Do not touch the radiator fan while it is running as this may cause injury.

2. When disassembling the radiator, be sure to do it when the car is cold and the engine is off.

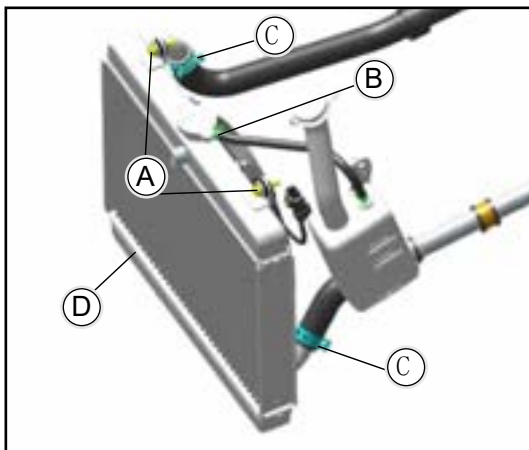

REMOVING THE ENGINE RADIATOR

- 【A】** Mounting bolts on engine radiator (M6X25)
- 【B】** Radiator overflow pipe clamps
- 【C】** Engine inlet and outlet pipe clamps
- 【D】** Engine radiator

- ◆ Remove the rear body plastic parts (see body section for details)
- ◆ Remove the overflow pipe clamp **【B】** and engine radiator hose clamp **【D】** with the appropriate tool.
- ◆ Remove the overflow pipe clamp **【B】** and the engine radiator inlet and outlet hose clamp **【C】** with a suitable tool, and pull out the overflow pipe hose and the engine radiator inlet and outlet hoses.
- ◆ Remove the overflow hose clamp **【B】** and the engine radiator inlet/outlet hose clamp **【C】** with a suitable tool.
- ◆ Remove the two radiator mounting bolts (M6X25).
- ◆ Remove the engine radiator

⚠ WARNING

Do not touch the heat sink core. This may damage the heatsink and result in a cooling efficiency.

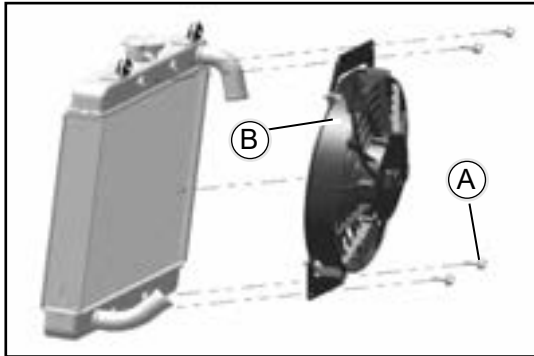

RADIATOR FAN REMOVAL/INSTALLATION

Radiator (see Radiator Removal)

- ◆ Radiator fan assembly bolts 【A】
- ◆ Fan assembly 【B】

⚠ WARNING

1. The opening and stopping of the radiator fan is controlled by the ECU of the whole vehicle, when the engine head water temperature reaches 90°C, the fan will be opened automatically.

When the cylinder head water temperature reaches 90°C, the fan will automatically turn on; until the cylinder head water temperature drops below 85°C, the radiator fan will automatically stop.

When the cylinder head water temperature drops below 85°C, the radiator fan stops automatically. Do not touch the radiator fan while it is running.

Do not touch the radiator fan while it is running as this may cause injury.

2. When disassembling the radiator, be sure to do it when the car is cold and the engine is off.

- ◆ Heatsink Fan Mounting Nut 【A】
- ◆ Radiator Fan 【B】
- ◆ Heat sink fan installation and removal in reverse order
- ◆ Tighten

Radiator fan assembly bolt torque 【A】

8.8 N·m (0.9 kgf·m, 78 in·lbs)

INTAKE / EXHAUST SYSTEM

EXPLODED VIEW OF INTAKE SYSTEM.....7-2

AIR FILTER REMOVAL7-3

 START BY PLACING THE CAR IN A HORIZONTAL POSITION7-3

 MOUNTING.....7-3

EXPLODED VIEW OF EXHAUST SYSTEM.....7-4

MUFFLERS AND EXHAUST PIPES7-5

 MUFFLER REMOVAL7-5

 PROBE.....7-6

 MOUNTING.....7-6

EXPLODED VIEW OF INTAKE SYSTEM

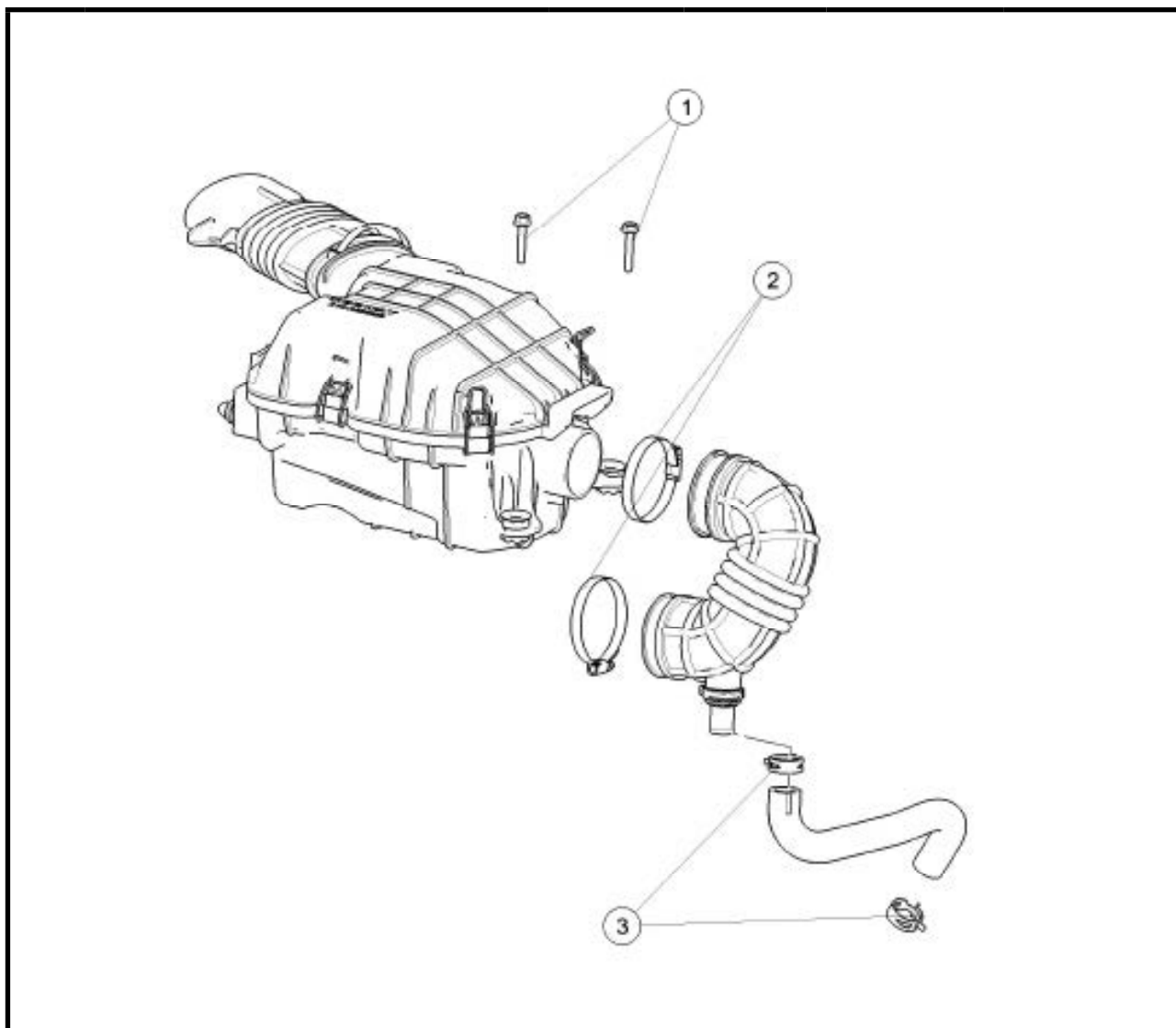

No.	Fastener	Torque			Remarks
		N·m	kgf·m	ft·lb	
1	Air filter mounting bolts M6×35	8 ~ 12	0.8~1.2	6~9	
2	Type A worm drive hose clamp 70				
3	Steel band elastic hose clamp 24				

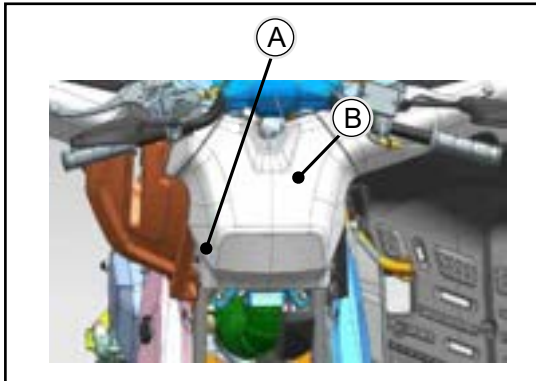
AIR FILTER REMOVAL**START BY PLACING THE CAR IN A HORIZONTAL POSITION**

【A】 Air filter cover

【B】 hexagonal screw

◆ Remove the 2 hexagonal screws 【A】

◆ Remove the air filter cover 【B】

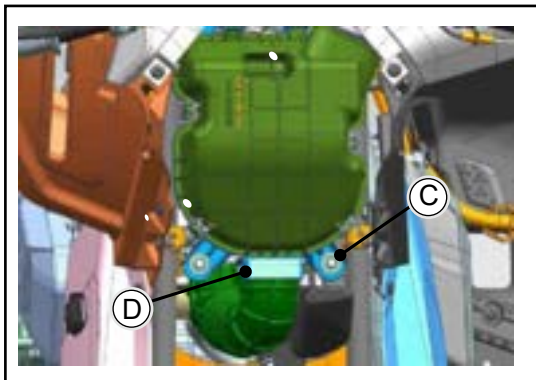

【C】 Air filter mounting bolts

【D】 Type A worm drive hose clamp 70

◆ Remove 2 mounting bolts 【C】

◆ Remove hose clamps 【D】

◆ Remove the entire air filter

MOUNTING

◆ Please assemble in reverse order of disassembly.

EXPLODED VIEW OF EXHAUST SYSTEM

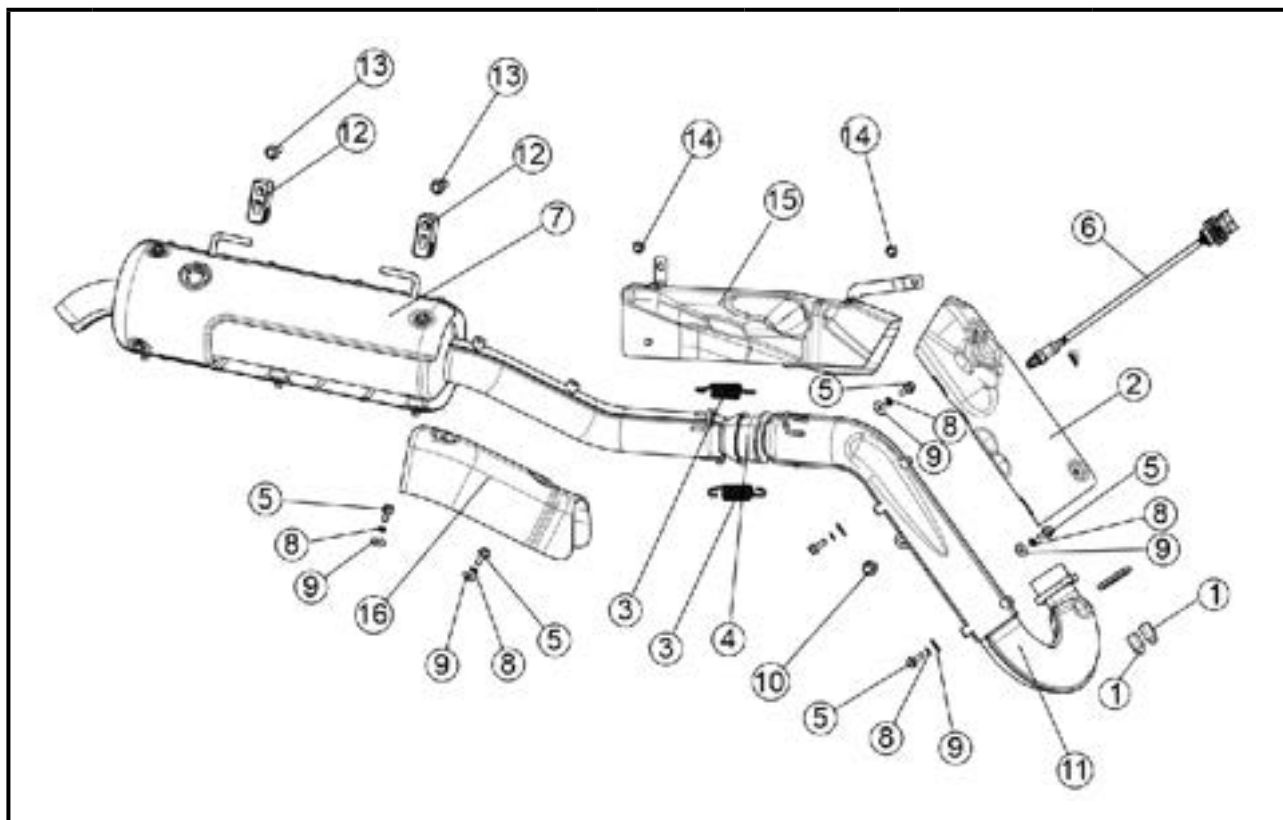

No.	Fastener	Torque			Remarks
		N·m	kgf·m	ft·lb	
1	Cap nut				
2	Front pipe heat shield				
3	Muffler tension spring				
4	Graphite sealed bowl				
5	Hexagon flange bolt m6×12	8 ~ 12	0.8~1.2	6~9	
6	M12 oxygen sensor				
7	Muffler cylinder combination				
8	Spring washer 6				
9	Large washer 6				
10	Hexagon flange bolt m8×25	20 ~ 25	2.0~2.5	14.7~18.4	
11	Exhaust pipe combination				
12	Cylinder hanging liner				
13	Hexagon flange bolt m8×35	20 ~ 25	2.0~2.5	14.7~18.4	
14	Hexagon flange bolt m8×16	20 ~ 25	2.0~2.5	14.7~18.4	
15	Heat shield assembly				
16	Cylinder front pipe heat shield				

MUFFLERS AND EXHAUST PIPES

⚠ WARNING

Whenever checking or maintaining components of the exhaust system, it is necessary to inspect whether each part of the exhaust system is overheated to avoid being scalded by high temperatures.

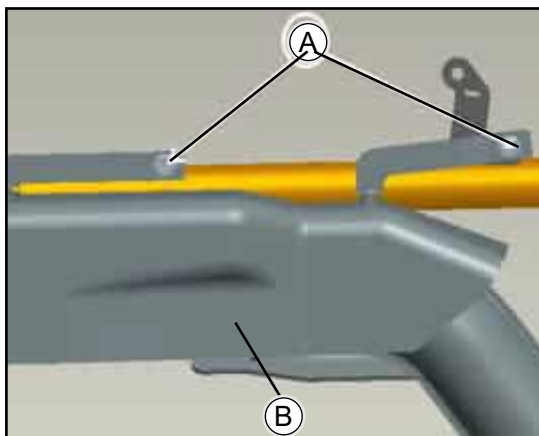
**MUFFLER REMOVAL**

- ◆ Remove bolts 【A】 ; remove heat shield assembly 【B】

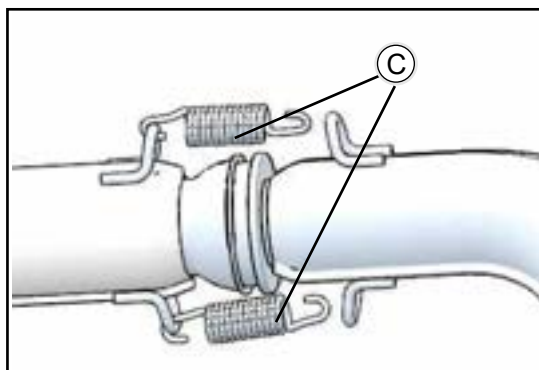

- ◆ Remove the spring 【C】

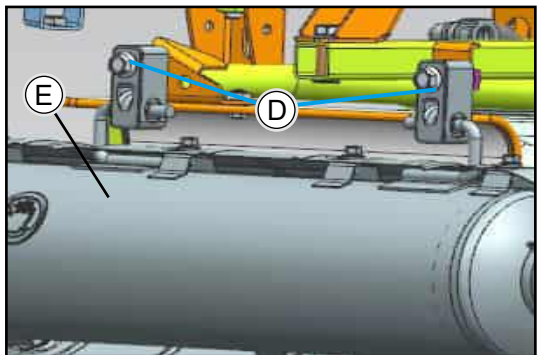

- ◆ Remove the bolt 【D】
- ◆ Remove the muffler 【E】

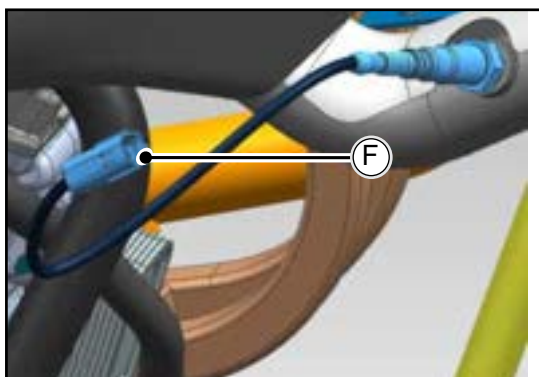

- ◆ Disconnect the oxygen sensor cable plug 【F】

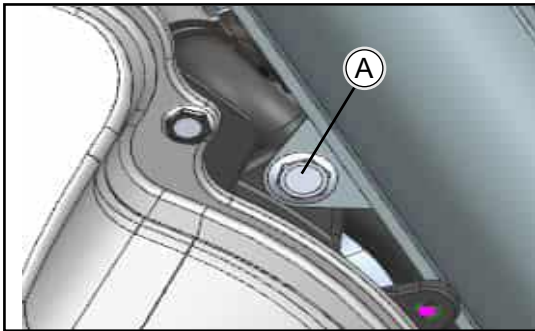

- ◆ Exhaust Pipe Removal
- ◆ Remove exhaust pipe bracket bolts 【A】
- ◆ Remove exhaust pipe retaining nut 【B】
- ◆ Remove exhaust pipe 【C】

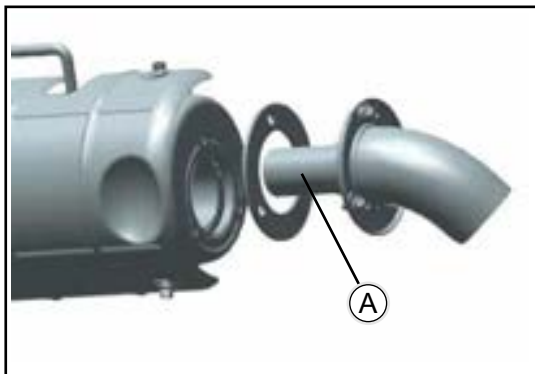
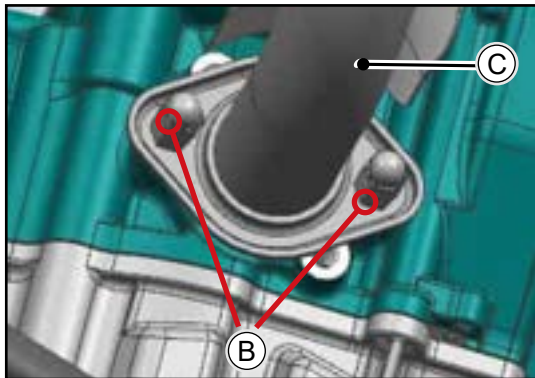

PROBE

- ◆ Check externally for cracks, holes or ruptures in the muffler, as this can affect engine performance and emissions. Replace corresponding parts if necessary.
- ◆ Check for looseness, rattles, debris, etc. inside the muffler by rocking the muffler back and forth.
- ◆ Check for air leaks at the connection between the exhaust pipe and the engine cylinder head, if so tighten the nut or replace the gasket.
- ◆ Check for air leaks at the connection between the exhaust pipe and the muffler, if so, tighten the bolts or replace the muffler spring and sealing sleeve.
- ◆ Check if there is carbon buildup on the screen of the spark arrestor 【A】 , if so clean it with a suitable brush, if the screen or gasket is damaged, it must be replaced.

MOUNTING

- ◆ Please assemble in reverse order of disassembly.

DRIVE SYSTEM

EXPLODED VIEW OF DRIVESHAFT (SINGLE CAB VEHICLES).....8-2
DRIVE SHAFT REMOVAL.....8-3
 REMOVAL OF FRONT DRIVE SHAFT8-4
 REAR DRIVE SHAFT ASSEMBLY DISASSEMBLY.....8-4
 FRONT AND REAR DRIVE SHAFT8-4
EXPLODED VIEW OF FRONT AND REAR LEFT/RIGHT CONSTANT VELOCITY DRIVE SHAFTS.....8-5
DOJ DRIVE SHAFT REPAIR.....8-6

EXPLODED VIEW OF DRIVESHAFT (SINGLE CAB VEHICLES)

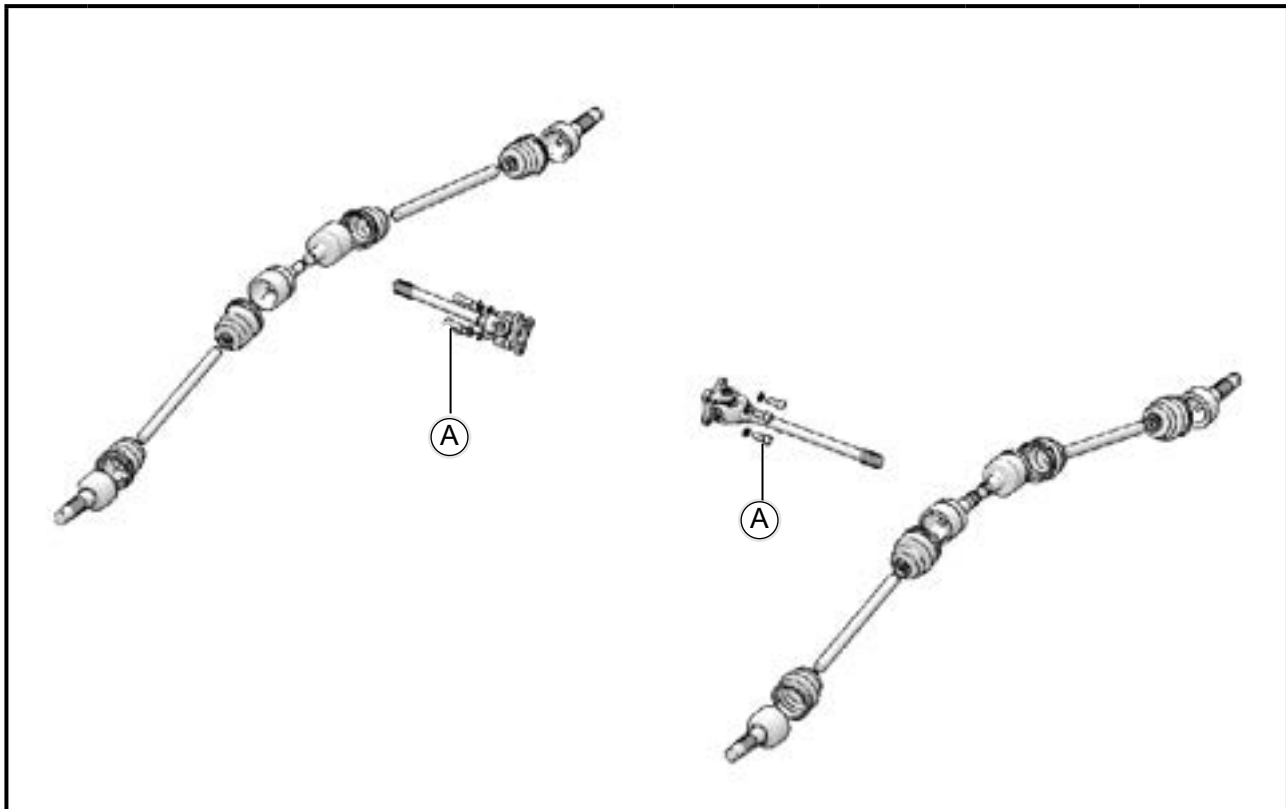

No.	Fastener	Torque			Remarks
		N·m	kgf·m	ft·lb	
1	Hexagon socket head screw M10×1.25×25	45	4.5	33	

A: Apply a non-permanent locking agent.

DRIVE SHAFT REMOVAL

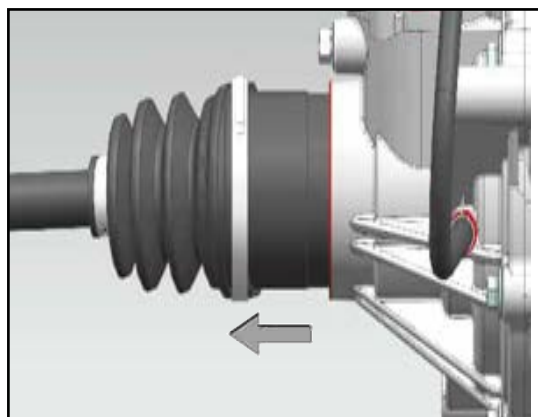
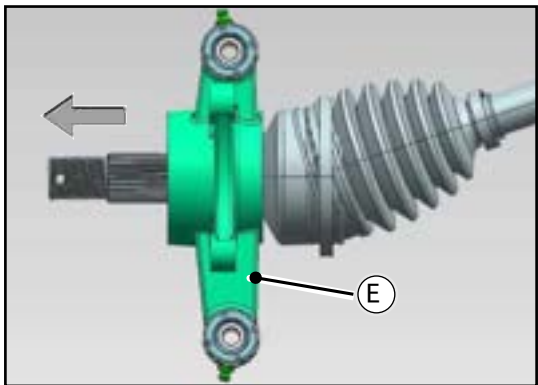
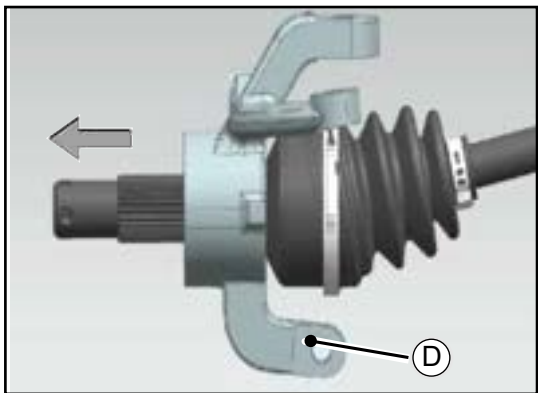
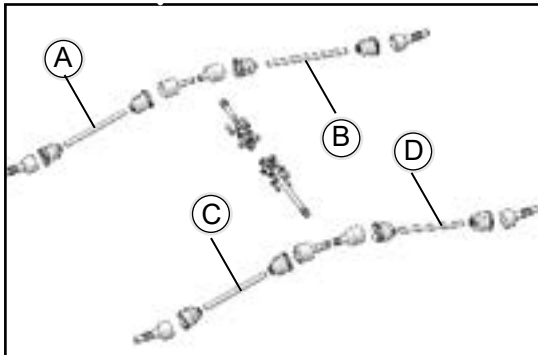
**⚠ WARNING**

Do not remove the dust boot when removing the drive shaft, it is filled with grease.

【A】 Front left constant velocity drive shaft assembly

【B】 Front right constant velocity drive shaft assembly

【C】 Rear left constant velocity drive shaft assembly

【D】 Rear right constant velocity drive shaft assembly

◆ When removing the drive shaft, start with the fixed end (wheel end) of the drive shaft.

◆ Remove the wheel train components and suspension components first (see the wheels and tires and suspension chapters for details)

【D】 Steering Knuckle

◆ Use a tool to remove the wheel axle support from the drive shaft in the direction indicated by the arrow in the left figure.

【E】 Axle support

◆ Use a tool to remove the wheel axle support from the drive shaft in the direction indicated by the arrow in the left figure.

◆ Pull out the drive shaft from the inside of the bridge in the direction shown by the arrow in the left figure until the drive shaft is loose and can be pulled out.

◆ Pull out the drive shaft from the inside of the bridge in the direction shown by the arrow in the left figure until the drive shaft is loose and can be pulled out.

REMOVAL OF FRONT DRIVE SHAFT

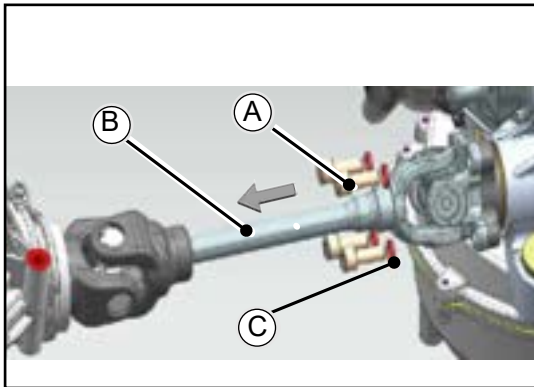

- 【A】 Hexagon socket head screw M10×1.25×25
- 【B】 Front drive shaft assembly
- 【C】 Diameter 10mm spring washer
- ◆ Loosen the screws 【A】 (4pcs)
- ◆ Spring washers 【C】 (4 pieces)
- ◆ Move the 【B】 front drive shaft assembly back in the direction of the arrow until it is removed

REAR DRIVE SHAFT ASSEMBLY DISASSEMBLY

- 【A】 Hexagon socket head screw M10×1.25×25
- 【B】 Rear drive shaft assembly
- 【C】 Diameter 10mm spring washer
- ◆ Loosen the screws 【A】 (4pcs)
- ◆ Spring washers 【C】 (4 pieces)
- ◆ Pull back the 【B】 rear drive shaft assembly in the direction of the arrow until it is removed.

FRONT AND REAR DRIVE SHAFT

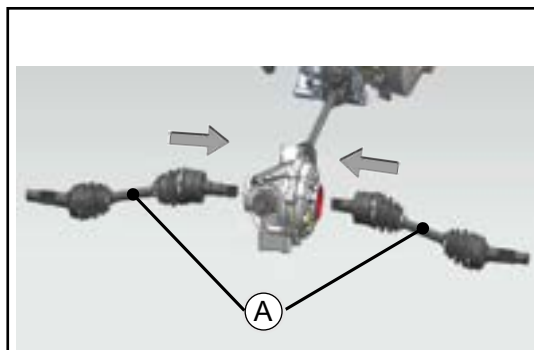

- 【A】 Front, rear, left and right constant speed drive shaft assembly
- ◆ Install the front and rear equal drive shaft assemblies and push them into the spline holes of the bridge in the direction of the arrow in the figure until the end, then install the upper and lower rocker arms and wheel supports, see the suspension part and the A wheel train part.
- ◆ The installation of the front and rear assembly of the transmission shaft is performed in reverse to the disassembly steps.

EXPLODED VIEW OF FRONT AND REAR LEFT/RIGHT CONSTANT VELOCITY DRIVE SHAFTS

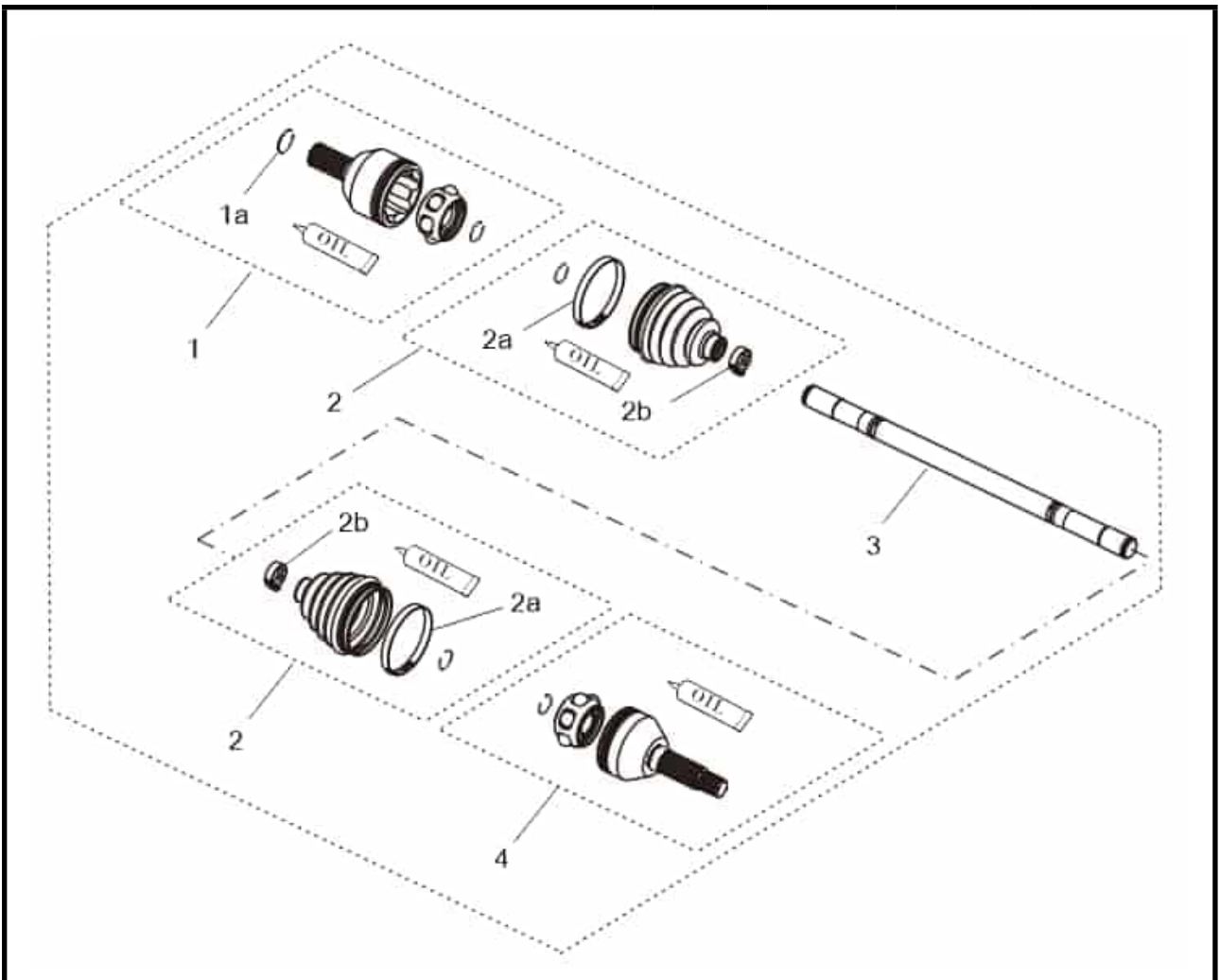

No.	Fastener	Torque			Remarks
		N·m	kgf·m	ft·lb	
1	Front and rear left/right inner ball cage assemblies				
1a	Retaining ring				
2	Front and rear axle left/right corrugated sleeve repair kit				
2a	large clamp				
2b	Small clamp				
3	Intermediate shaft				
4	Front and rear left/right outer cage assemblies				

DOJ DRIVE SHAFT REPAIR

⚠ CAUTION

The drive shaft is a precision part. Cleanliness must be ensured when replacing and installing, and the operation must be strictly followed the instructions. Do not use a hammer or sharp objects for disassembly and installation, which will affect the performance and service life of the half shaft.



- ◆ Use clamp pliers to clamp the clamp, then place a small screwdriver on the end of the clamp, lift the clamp up and release the clamp clamp at the same time, and remove the clamp;



- ◆ Remove the clamps at both ends of the dust cover, and pull the dust cover out for a certain distance along the direction of the middle axis;



- ◆ Use a sharper tool to take out the retaining ring in the universal joint;



- ◆ After taking out the retaining ring, you can directly pull out the intermediate shaft, pay attention not to drop the steel balls on the cage and the star sleeve, and clean the grease in the universal joint and the dust cover;

⚠ CAUTION

If only the lubricating grease is replaced, the remaining lubricating grease inside the universal joint needs to be cleaned up, and it is forbidden to mix different lubricating greases or use other lubricating greases instead.



- ◆ Use retaining ring pliers to remove the retaining ring of the star sleeve, after replacing the universal joint or dust cover, install the star sleeve in situ, and finally install the retaining ring;

⚠ CAUTION

The interior of the star sleeve is a precision component, and it is not recommended to disassemble and repair it separately. If it is damaged or the internal grease is polluted or liquefied, the universal joint needs to be replaced as a whole.

- ◆ Inject lubricating grease into the universal joint and dust cover, and then install the star-shaped sleeve assembly into the universal joint. Pay attention to the number of steel balls in the star-shaped sleeve. If the number is wrong, it is not allowed to install;

⚠ CAUTION

If only the lubricating grease is replaced, the remaining lubricating grease inside the universal joint needs to be cleaned up, and it is forbidden to mix different lubricating greases or use other lubricating greases instead.

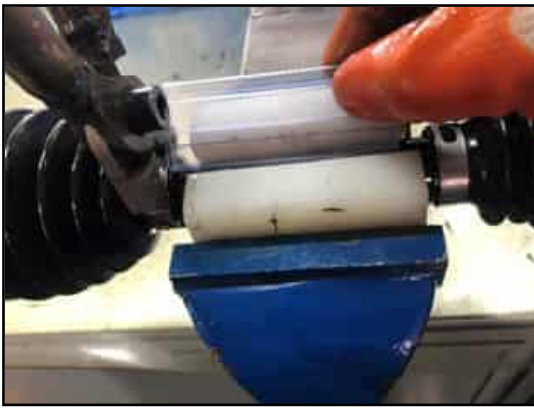

- ◆ First install the small clamp, adjust the position of the dust cover to ensure that the dust cover is stuck in the groove of the intermediate shaft, and then use the clamp pliers to clamp the small clamp;



- ◆ When installing the large clamp, first clamp the dust cover in the groove of the universal joint, then discharge the gas in the dust cover, use a screwdriver to lift a corner of the dust cover, be careful not to puncture the dust cover, and then back and forth Push and pull the universal joint, you can hear the sound of gas flow, stop the universal joint in the middle position, take out the screwdriver and clamp the big clamp;

- ◆ Wipe the grease on the universal joint and the intermediate shaft before use;
- ◆ The above maintenance procedures are applicable to the inner and outer ball cages of the front and rear left/right equal drive shafts.

INTAKE / EXHAUST SYSTEM

EXPLODED DIAGRAM OF FRONT SUSPENSION	9-2
REAR SUSPENSION EXPLOSION DIAGRAM	9-3
TECHNICAL PARAMETER	9-4
DEDICATED TOOLS	9-5
SHOCK ABSORBER	9-6
SHOCK ABSORBER INSPECTION.....	9-6
ORDINARY HYDRAULIC DAMPING AND SHOCK ABSORPTION PRELOAD ADJUSTMENT	9-6
SPRING ADJUSTMENT TABLE.....	9-6
AIR DAMPING SHOCK PRELOAD ADJUSTMENT.....	9-6
MEASURE THE FREE LENGTH OF THE SPRING	9-7
SHOCK ABSORBER DAMPING ADJUSTMENT	9-7
COMPRESSION DAMPING ADJUSTMENT.....	9-7
RECOVERY DAMPING ADJUSTMENT.....	9-8
SHOCK ABSORBER REMOVAL.....	9-8
FRONT SHOCK ABSORBER INSTALLATION	9-8
REAR SHOCK ABSORBER SCRAPPED	9-9
ADJUSTABLE GAS SHOCK ABSORBER INSPECTION	9-9
SUSPENSION	9-10
REMOVAL OF THE ROCKER ARM.....	9-10
DISASSEMBLY OF ROCKER ARM	9-11
ROCKER INSTALLATION	9-11
ROCKER ARM MAINTENANCE	9-12
HUB BEARING REPLACEMENT.....	9-13
DISASSEMBLY OF REAR AXLE SUPPORT ASSEMBLY	9-13
REAR BALANCE BAR	9-14
REAR STABILIZER BAR DISASSEMBLY.....	9-14
REAR STABILIZER BAR MAINTENANCE	9-14

EXPLODED DIAGRAM OF FRONT SUSPENSION

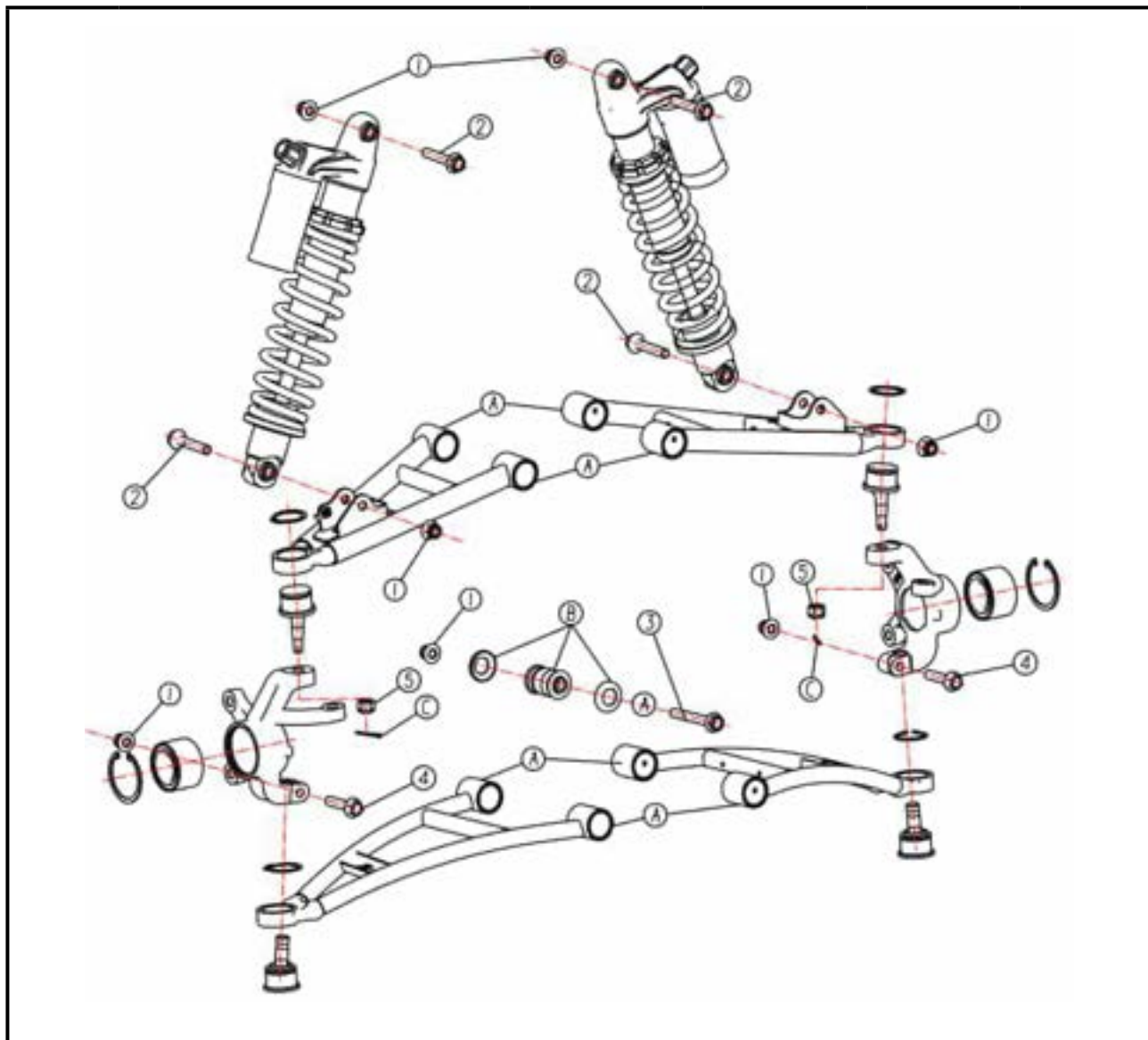

No.	Fastener	Torque			Remarks
		N·m	kgf·m	ft·lb	
1	Hex flange lock nut M10×1.25	40~50	4.0~5.0	29.5~36.9	
2	Shock absorber mounting bolts M10×1.25×55	40~50	4.0~5.0	29.5~36.9	
3	Rocker arm mounting bolts M10×1.25×75	55~65	5.6~6.6	40.5~47.9	
4	Mounting bolts under steering knuckle M10×1.25×45	40~50	4.0~5.0	29.5~36.9	
5	Slotted nut M10×1.25	40~50	4.0~5.0	29.5~36.9	

Remark:

C-----replacement parts

REAR SUSPENSION EXPLOSION DIAGRAM

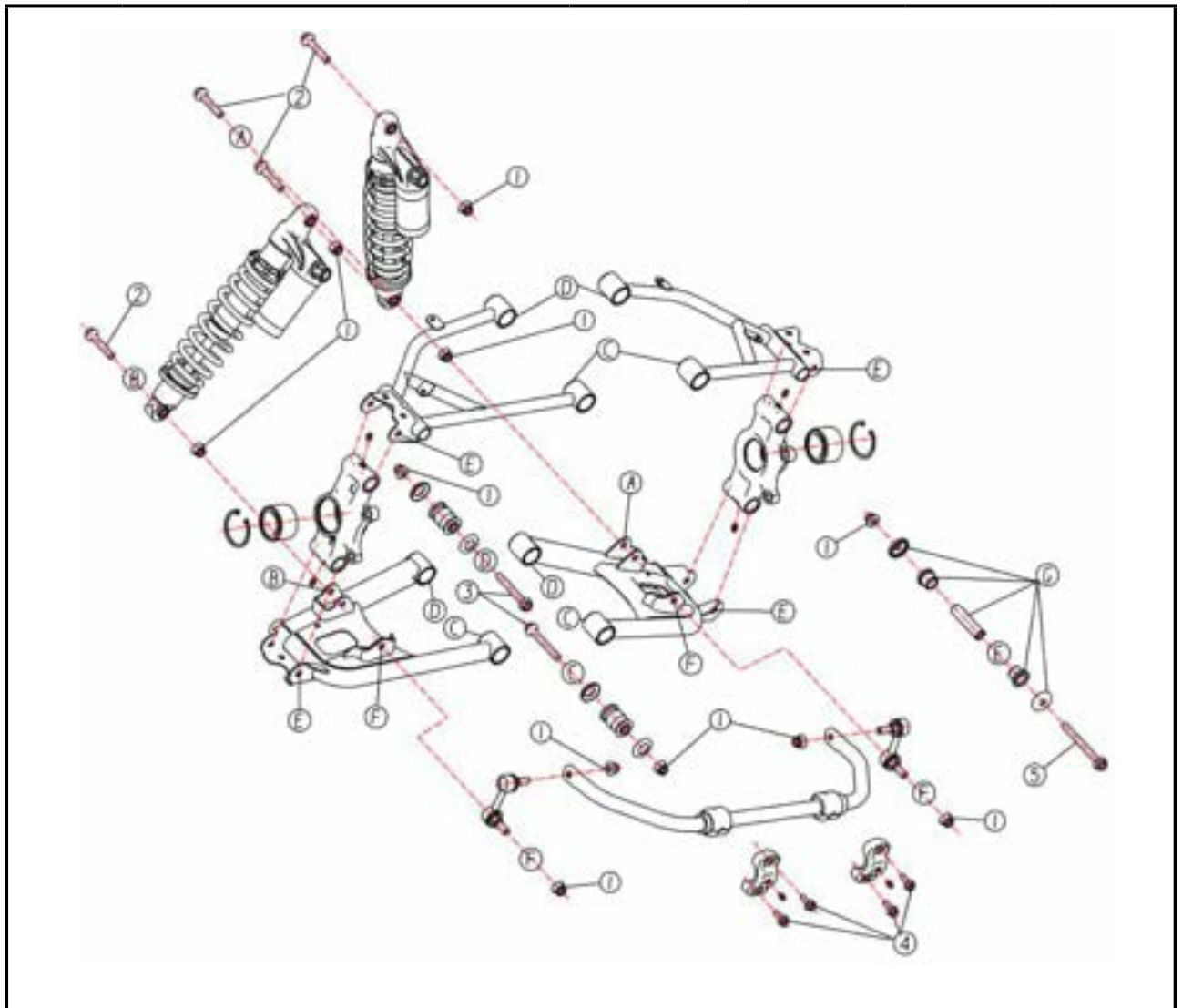

No.	Fastener	Torque			Remarks
		N·m	kgf·m	ft·lb	
1	Hex flange lock nut M10×1.25	40~50	4.0~5.0	29.5~36.9	
2	Shock absorber mounting bolts M10×1.25×55	40~50	4.0~5.0	29.5~36.9	
3	Rocker arm mounting bolts M10×1.25×75	55~65	5.6~6.6	40.5~47.9	
4	Mounting bolts for rear stabilizer bar M8×1.25×20	20~25	2.0~2.5	14.7~18.4	
5	Rear support mounting bolts M10×1.25×100	40~50	4.0~5.0	29.5~36.9	

Remark:

G----- Add grease through the oil cup nozzle (1000Km/time)

TECHNICAL PARAMETER

ITEM	SETTING	AVAILABLE RANGE
Front Shock Absorber: (Optional) <ul style="list-style-type: none"> • Ordinary hydraulic damping shock absorber spring preload setting position • Type A: air pressure adjustable damping shock spring preload setting position (from the bottom of the upper mounting base to the position of the adjusting nut) 	3 gear	1st gear to 5th gear
	36mm(1.42in.)	16~56mm (0.63~2.20in.)
Rear Shock Absorber: (Optional) <ul style="list-style-type: none"> • Ordinary hydraulic damping shock absorber spring preload setting position • Air pressure adjustable damping shock spring preload setting position (from the bottom of the upper mount to the position of the adjustment nut) 	3 gear	1st gear to 5th gear
	43mm(1.69in.)	23~63mm (0.91~2.48in.)
Barometric damping <ul style="list-style-type: none"> • Compression damping adjustment (adjust from clockwise) • Return damping adjustment (adjust from clockwise) • Gas pressure 	Type A: 9 gears Type B: 4 gears	Type A: 1st gear to 18th gear Type B: 1st gear to 7th gear
	Type A: 9 gears Type B: 4 gears	Type A: 1st gear to 18th gear Type B: 1st gear to 7th gear
	1Mpa	

DEDICATED TOOLS

Slotted screwdriver

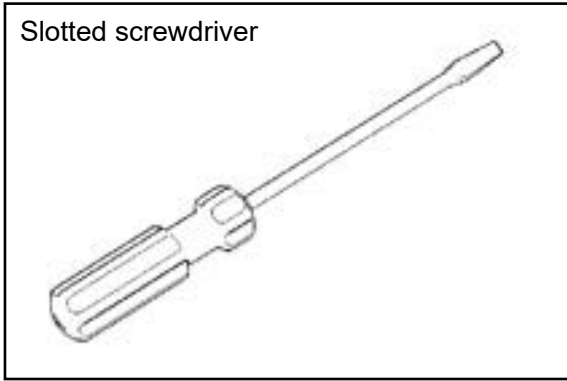

Needle nose pliers

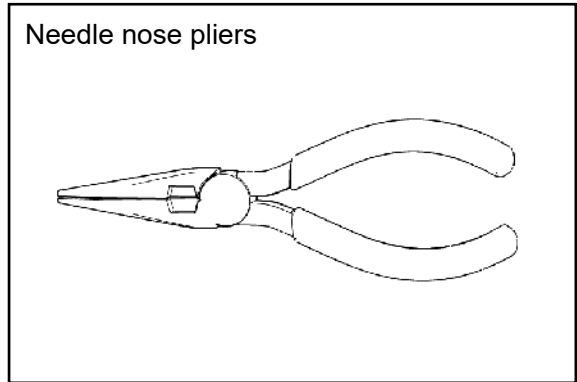

Grease gun

Hook wrench

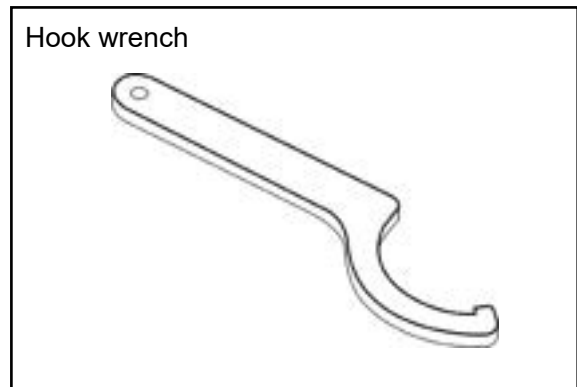

Internal circlip pliers

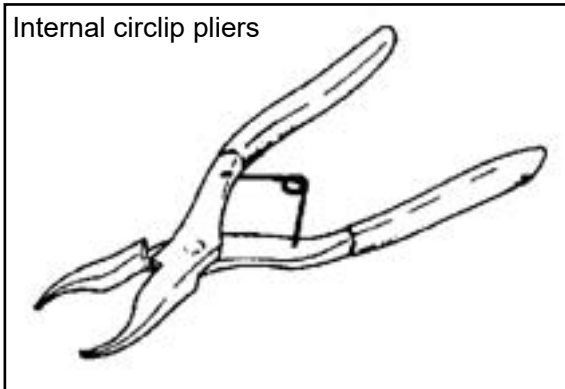

Bearing drive kit



Lifting jack

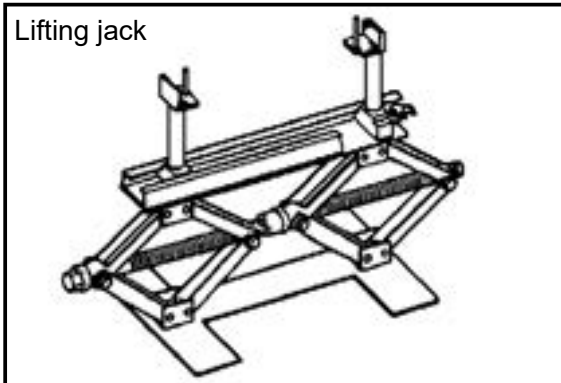

SHOCK ABSORBER

SHOCK ABSORBER INSPECTION

Since the front shocks are sealed units, they cannot be disassembled, only external inspection is required. If one unit is damaged, replace both shock absorbers as a set. If only one unit is replaced and both are not balanced, it may result in vehicle instability at high speeds or poor overall comfort.

ORDINARY HYDRAULIC DAMPING AND SHOCK ABSORPTION PRELOAD ADJUSTMENT

【A】 Spring adjustment sleeve

The spring adjustment sleeve [A] of the hydraulic shock absorber has 5 adjustment gears, and the spring can be adjusted according to different terrain and loading conditions. If the spring action feels too soft or too hard, it can be adjusted according to the spring adjustment table.

SPRING ADJUSTMENT TABLE

Position	Spring	Environment	Load	Terrain	Speed
1	Soft ↑	Soft ↑	Light ↑	Flat ↑	Low ↑
2 (STD)					
3	↓	↓	↓	↓	↓
4					
5	Hard	Hard	Heavy	Bumpy	High

◆ Use a tool to turn the adjustment sleeve on the shock absorber to the required gear.

AIR DAMPING SHOCK PRELOAD ADJUSTMENT

【B】 Hook wrench

◆ The spring adjusting nut of the gas pressure damping shock absorber is on the upper end of the spring, use tool [B] to loosen the locking nut. Then turn the adjusting nut to loosen.

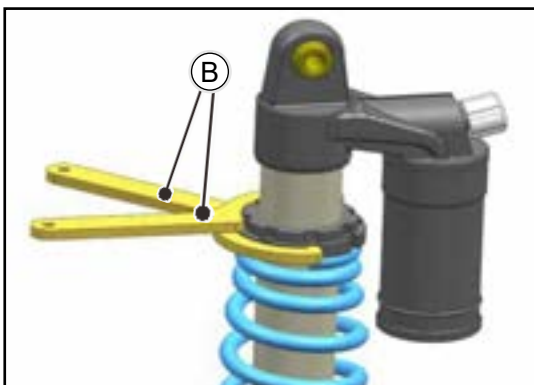
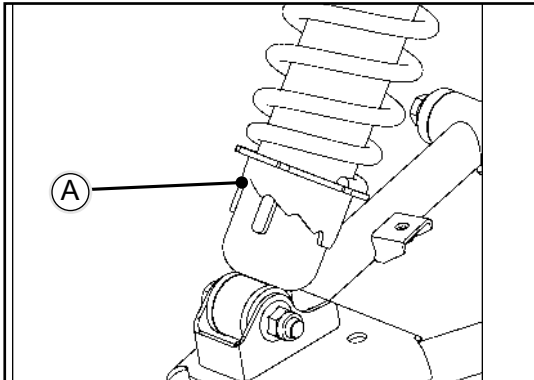

MEASURE THE FREE LENGTH OF THE SPRING

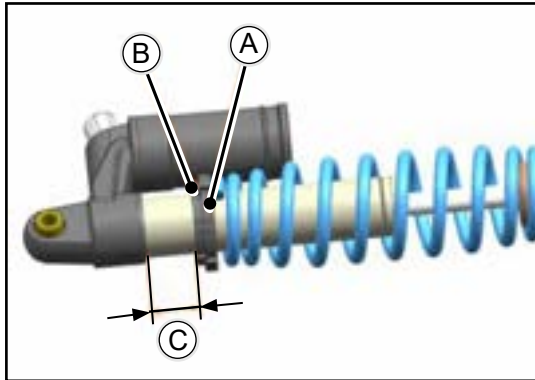

【A】 Adjusting nut

【B】 Lock Nut

【C】 Spring preload position

◆ Screw the adjusting nut 【A】 to the desired position, then tighten the lock nut 【B】 , adjust the nut position 【C】

Spring preload position [C] setting

Standard: Front shock 36mm(1.42in.),

Use range 16mm(0.63in.) ~ 56mm(2.20in.)

Rear shock 43mm(1.69in.),

Use range 23mm(0.91in.)~63mm(2.48in.)

Spring lock nut torque
30 N·m

If the spring action feels too soft or too hard, tune it to:

position	spring	setting	load	terrain	speed
↑ standard position	soft	soft	light	smooth	low
	↑	↑	↑	↑	↑
↓	↓	↓	↓	↓	↓
	hard	hard	heavy	bumpy	high

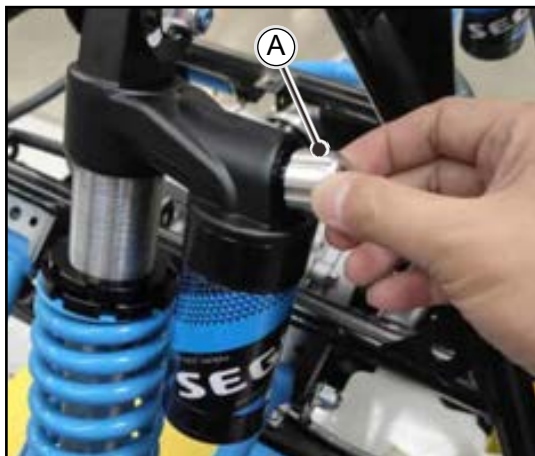

SHOCK ABSORBER DAMPING ADJUSTMENT

In order to adapt to various riding conditions, the spring preload can be adjusted on the shock absorber or the spring can be replaced. The damping force can also be easily adjusted without changing the oil viscosity.

COMPRESSION DAMPING ADJUSTMENT

◆ Turn the upper compression damping adjuster 【A】 by hand, clockwise to increase the damping, counterclockwise to decrease the damping.

Type A: The compression damping adjuster has a total of 18 gears, and the factory setting gear is the 9th gear.

Type B: The compression damping adjuster has a total of 7 gears, and the factory setting gear is the 4th gear.

Type A



RECOVERY DAMPING ADJUSTMENT

Type A: Use a flat-blade screwdriver to turn the damping adjuster at the bottom. Instantly increase the damping in the needle direction (H) and decrease the damping in the counterclockwise direction (S).

The recovery damping adjuster has 7 gears in total, and the factory setting gear is the 4th gear.

Utensils: Slotted screwdriver

Type B: Turn the damping adjuster at the bottom by hand to increase the damping in the clockwise direction (S) and the damping in the counterclockwise direction (F).

The recovery damping adjuster has 18 gears in total, and the factory setting gear is 9 gears.

Type B

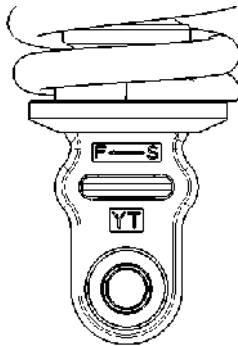

SHOCK ABSORBER REMOVAL

【A】 Front shock absorber

【B】 Mounting bolt

Use a jack or stand to prop up the vehicle so the wheels don't touch the ground.

- ◆ Use tools to remove the mounting bolts and nuts on the upper and lower parts of the shock absorber 【B】
- ◆ Take out the front shock absorber 【A】

FRONT SHOCK ABSORBER INSTALLATION

- ◆ Install the upper end of the front shock absorber into the mounting seat of the frame, and put on the bolts and nuts
- ◆ Insert the lower end of the front shock absorber into the front rocker arm mounting base, and install the bolts and nuts
- ◆ Use tools to tighten the upper and lower mounting bolts and nuts.

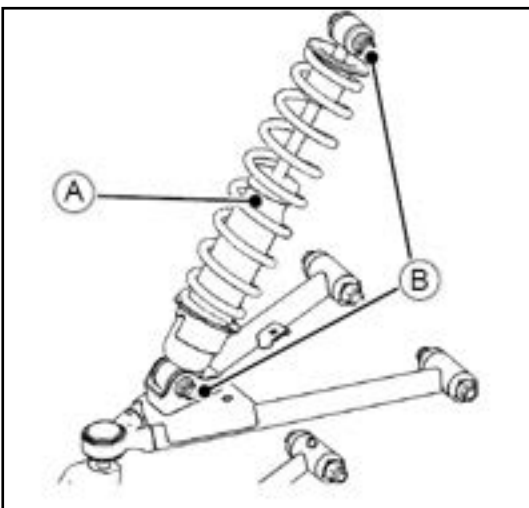

Shock absorber fixing nut torque

45 N·m (4.4kgf·m, 32ft·lb)

REAR SHOCK ABSORBER SCRAPPED

⚠ WARNING

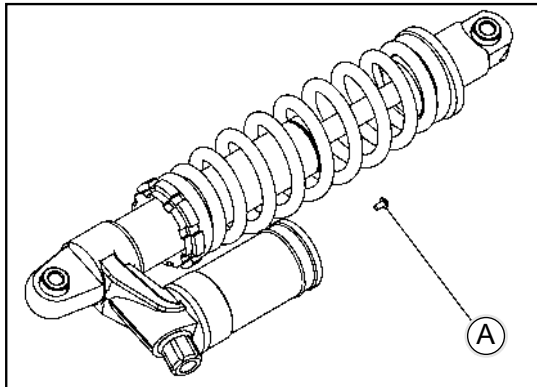

Since the rear shock absorber reservoir contains nitrogen gas, do not incinerate any unreleased gas in the container or it may explode.

【A】 Valve cover

- ◆ Remove the shock absorber (see Shock Absorber Removal)
- ◆ Remove the valve cover **【A】** and release nitrogen
- ◆ Remove the valve

⚠ WARNING

Because high-pressure gas is dangerous, do not point the valve toward your face or body.

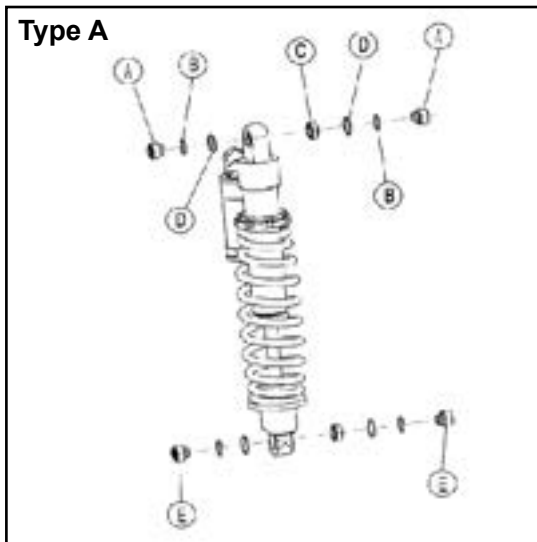

Type A

ADJUSTABLE GAS SHOCK ABSORBER INSPECTION

Type A

- ◆ Check the upper and lower mounting bases
- ◆ If spacer rings, joint bearing assemblies and oil seals are damaged, replace them.

- 【A】** upper spacer ring
- 【B】** O-ring
- 【C】** Joint bearing combination
- 【D】** Retaining ring
- 【E】** Lower spacer ring

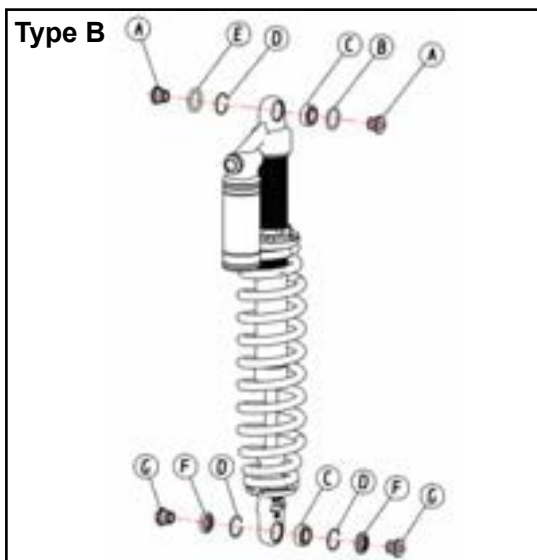

Type B

Type B

- 【A】** upper spacer ring
- 【B】** O-ring I
- 【C】** Joint bearing combination
- 【D】** Retaining ring
- 【E】** O-ring II
- 【F】** Sealing rubber sleeve
- 【G】** Lower spacer ring

SUSPENSION

REMOVAL OF THE ROCKER ARM

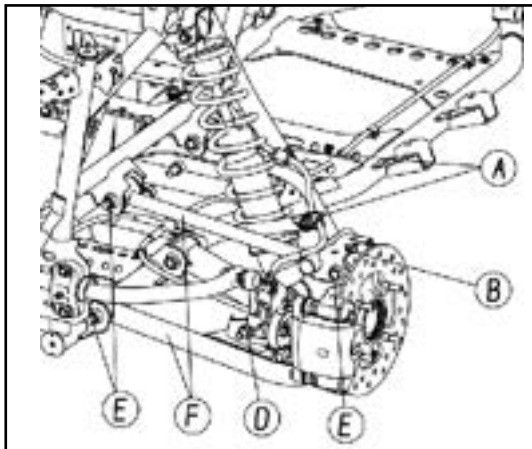

- 【A】 Brake hose fixing bolt
 - 【B】 Steering knuckle \ axle support assembly
 - 【C】 Tie rod nut
 - 【D】 Ball Pin Connecting Rod Nut
 - 【E】 Rocker arm mounting bolt
 - 【F】 rocker arm assembly
- ◆ Remove the brake caliper mounting bolts and remove the caliper body
 - ◆ Remove the brake hose fixing bolt 【A】
 - ◆ Remove the steering knuckle\axle support assembly 【B】
 - ◆ Remove the steering tie rod nut 【C】
 - ◆ Remove the ball pin connecting rod bolt 【D】
 - ◆ Remove the rocker arm mounting bolt fasteners 【E】
 - ◆ Remove the rocker arm assembly 【F】

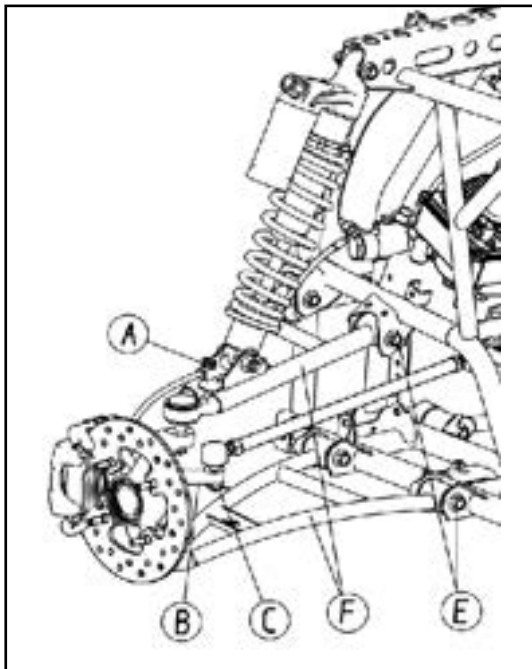

DISASSEMBLY OF ROCKER ARM

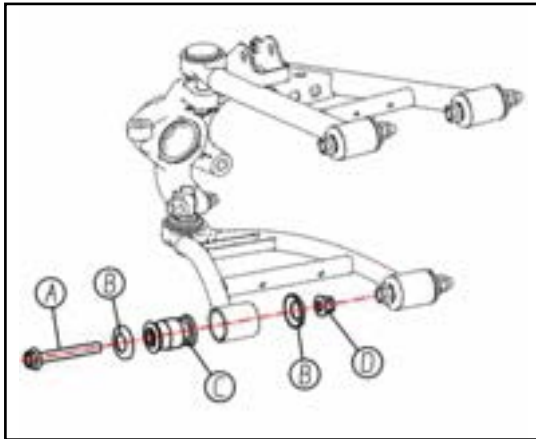

- 【A】 Rocker arm assembly mounting bolts
- 【B】 Rocker arm dust cover
- 【C】 Rocker arm buffer bushing
- 【D】 Nut
- 【E】 Retaining ring for shaft
- 【F】 Upper and lower kingpin assembly
- ◆ Remove the rocker arm assembly mounting bolts 【A】 and nuts 【D】
- ◆ Remove the rocker arm dust cover 【B】
- ◆ Press out the rocker arm buffer bush 【C】
- ◆ Use snap ring pliers to remove the shaft circlip 【E】
- ◆ Press out the upper and lower kingpin components 【F】

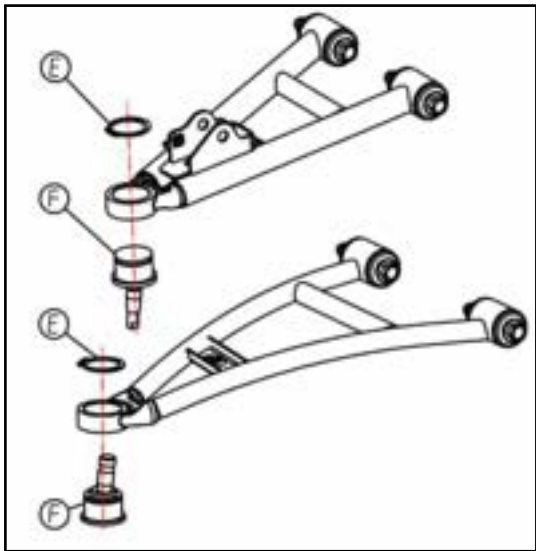

ROCKER INSTALLATION

- ◆ Tighten

Rocker arm assembly mounting bolt/ steering rod end nut
--

60 N·m (6 kgf·m, 44 ft·lb)

Stabilizer bar assembly mounting bolts
--

35N·m (3.5 kgf·m, 25.8 ft·lb)

ROCKER ARM MAINTENANCE

【A】 Straight-through oil cup

- ◆ Use a grease gun to fill the straight-through oil cup with grease
- ◆ When the inspection finds that the lubricating grease in the hub of the axle support is reduced, or after the vehicle travels 1000Km, use a grease gun to fill the straight-through oil cup in the suspension system (including the rear axle support and rear stabilizer bar).

Special tools: grease gun

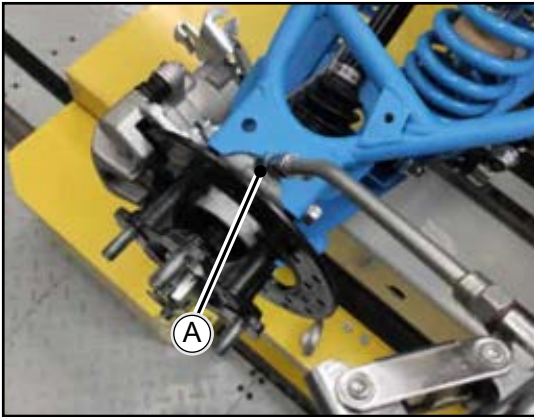

⚠ WARNING

If the suspension joints do not have adequate lubrication, they need to be lubricated and maintained regularly to avoid excessive wear of the bushings.

HUB BEARING REPLACEMENT

If the hub bearing in the steering knuckle assembly and rear axle support assembly is damaged, it needs to be replaced.

- 【A】 Open retaining ring
- 【B】 Wheel hub bearing
- 【C】 Front steering knuckle
- 【D】 Rear wheel axle support

Special tools: circlip pliers, bearing driver set

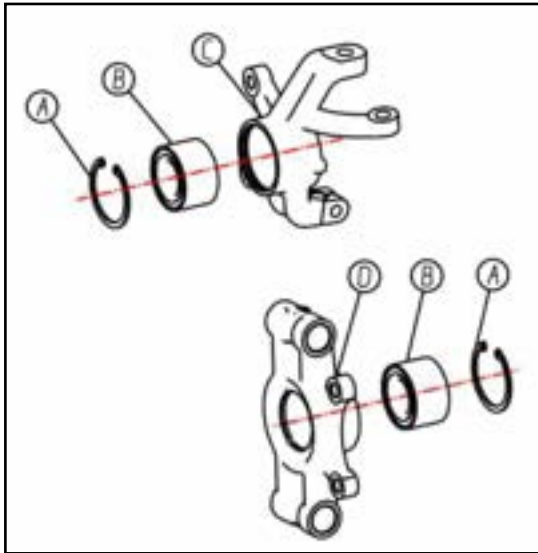

DISASSEMBLY OF REAR AXLE SUPPORT ASSEMBLY

- 【A】 Oil seal cover
- 【B】 Buffer sleeve
- 【C】 Axle support liner
- 【D】 Wheel hub bearing
- 【E】 Open retaining ring
- 【F】 Straight-through oil cup (grease nipple)

Special tools: circlip pliers, bearing driver set

⚠ CAUTION

Check the buffer sleeve [B]. If the inner hole is severely worn, it needs to be replaced and refilled with grease after assembly.

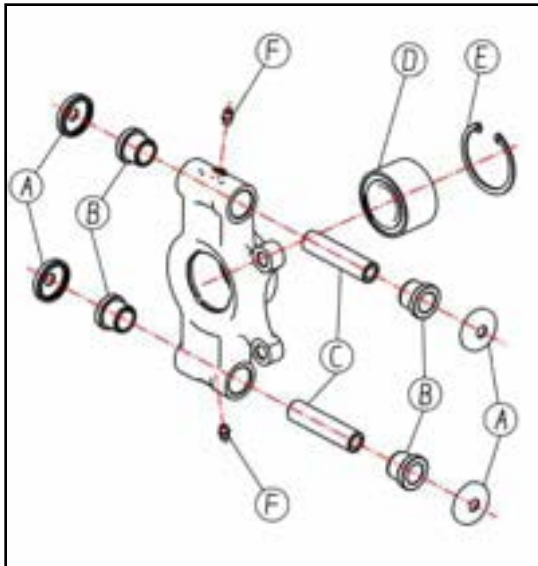

REAR BALANCE BAR

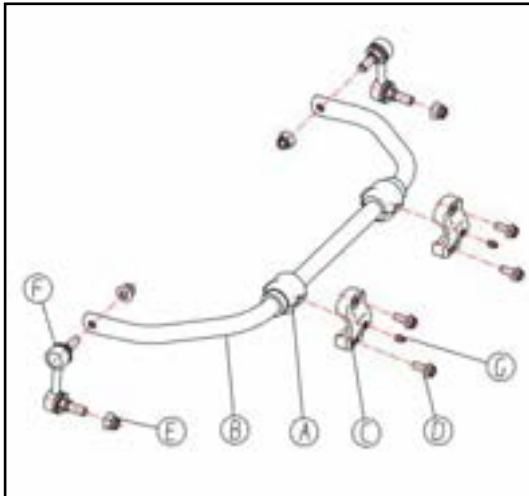

REAR STABILIZER BAR DISASSEMBLY

- 【A】 Stabilizer bar buffer sleeve
- 【B】 Rear stabilizer bar
- 【C】 Stabilizer bar mounting base
- 【D】 Mounting base fixing bolts
- 【E】 Connecting rod assembly mounting nut
- 【F】 Connecting rod assembly
- 【G】 Straight-through oil cup

Mounting seat fixing bolt torque

35N·m (3.5 kgf·m, 25.8 ft·lb)

Connecting rod assembly mounting nut torque

45 N·m (4.5 kgf·m, 33 ft·lb)

REAR STABILIZER BAR MAINTENANCE

- 【A】 Straight-through oil cup

Every time the vehicle travels 1000KM, it is necessary to add an appropriate amount of grease to the buffer sleeve installed on the stabilizer bar through the straight-through oil cup [A].

Special tools: grease gun

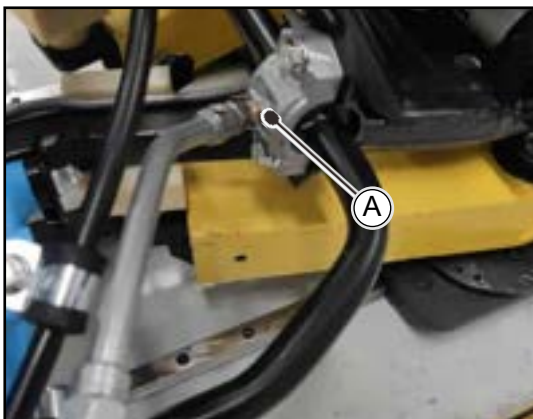

BRAKE SYSTEM

EXPLODED VIEW OF BRAKING SYSTEM	11-3
PARKING BRAKE EXPLOSION DIAGRAM	11-4
SPECIFICATIONS	11-4
TECHNICAL PARAMETERS	11-5
SPECIAL TOOLS	11-5
BRAKE FLUID	11-6
BRAKE FLUID REPLACEMENT/BRAKE BLEEDING.....	11-6
FOOT BRAKE MASTER CYLINDER REPAIR	11-8
FOOT BRAKE MASTER CYLINDER DISASSEMBLY.....	11-8
HANDBRAKE MAIN PUMP BRAKE FLUID FILLING	11-9
FOOT BRAKE MASTER PUMP BRAKE FLUID FILLING	11-9
MASTER PUMP INSTALLATION.....	11-10
FRONT BRAKE ASSEMBLY	11-11
REMOVAL OF FRONT BRAKE ASSEMBLY.....	11-11
FRONT BRAKE ASSEMBLY INSTALLATION.....	11-11
FRONT BRAKE CALIPER BODY	11-12
FRONT BRAKE CALIPER BODY REMOVAL.....	11-12
FRONT BRAKE CALIPER BODY INSTALLATION	11-13
FRONT BRAKE PAD	11-14
FRONT BRAKE PAD REMOVAL.....	11-14
FRONT BRAKE PAD INSTALLATION.....	11-14
FRONT BRAKE PAD WEAR INSPECTION.....	11-14
FRONT BRAKE DISC	11-15
FRONT BRAKE DISC CLEANING.....	11-15
FRONT BRAKE DISC REMOVAL.....	11-15
FRONT BRAKE DISC INSTALLATION.....	11-15
FRONT BRAKE DISC INSPECTION.....	11-15
REAR BRAKE ASSEMBLY	11-16
REAR BRAKE ASSEMBLY REMOVAL.....	11-16
REAR BRAKE ASSEMBLY INSTALLATION.....	11-16
REAR BRAKE CALIPER BODY	11-17
REAR BRAKE CALIPER BODY REMOVAL.....	11-17
REAR BRAKE CALIPER BODY INSTALLATION.....	11-18
REAR BRAKE PAD	11-19
REAR BRAKE PAD REMOVAL.....	11-19
REAR BRAKE PAD INSTALLATION.....	11-19
REAR BRAKE PAD WEAR INSPECTION.....	11-19
REAR BRAKE DISC	11-20
REAR BRAKE DISC CLEANING.....	11-20
REAR BRAKE DISC REMOVAL.....	11-20
REAR BRAKE DISC INSTALLATION.....	11-20
REAR BRAKE DISC INSPECTION.....	11-20
BRAKE HOSES	11-21
BRAKE HOSE INSPECTION.....	11-21
REAR BRAKE PEDAL	11-21
BRAKE PEDAL POSITION ADJUSTMENT.....	11-21
REAR BRAKE PEDAL REMOVAL.....	11-21
INSTALLATION OF REAR BRAKE PEDAL.....	11-21
PARKING CABLE	11-22
PARKING CABLE REMOVAL.....	11-22
INSTALLATION OF PARKING CABLE.....	11-22
TROUBLESHOOTING BRAKE NOISE.....	11-23
BRAKE SYSTEM TROUBLESHOOTING	11-23

Disc brake systems are lightweight, low-maintenance and perform well in conditions commonly encountered by vehicles. When replacing disc brake pads or performing brake system repairs, there are a few things to remember to ensure proper system function and maximum brake pad life.

- ◆ Do not overfill the master cylinder reservoir.
- ◆ Make sure the brake pedal moves freely and is not stuck.
- ◆ After replacing or repairing the brake pads, check and adjust the fluid level in the master cylinder reservoir.
- ◆ Make sure the atmospheric vent on the reservoir is clear.
- ◆ Test brake drag after any brake system repairs and, if brake drag is evident, investigate the cause.
- ◆ Make sure the caliper moves freely on the guide pins (if applicable).
- ◆ Inspect the caliper piston seal for foreign matter that may prevent the caliper piston from returning freely.
- ◆ After installing new brake pads, perform a brake break-in procedure to extend service life.
- ◆ Do not use aerosols or petroleum products to lubricate or clean brake components. Use only approved brake cleaning products.

The braking system consists of the following components or assemblies: brake pedal, master cylinder, hydraulic brake lines, brake calipers, brake pads and brake discs.

When braking is initiated, pressure is applied to the piston in the master cylinder by pressing the brake pedal. As the master cylinder piston moves inward, it closes the small opening in the cylinder (the compensating port) and begins to build pressure within the braking system. When the pressure in the system increases, the piston in the brake caliper moves outward to push the brake pad into contact with the brake disc and apply clamping pressure to the brake disc. This creates a gap between the brake pad and the brake disc. Friction to achieve the purpose of deceleration or braking. The friction exerted on the brake pads causes the brake pads to wear. As these brake pads wear, the pistons in the calipers move further outward and adjust themselves to automatically compensate. As the brake caliper piston moves outward, fluid from the reservoir fills the increased amount of fluid in the lines required due to wear on the brake pads or discs. Brake fluid level is critical to the proper operation of the system. Too little fluid can allow air to enter the system and make the brakes feel spongy. Excess fluid can cause the brakes to drag due to fluid expansion. The compensation port is located in the master cylinder and opens and closes according to the movement of the master cylinder piston. This port compensates for the expansion or contraction of the fluid as the temperature within the hydraulic system changes. Since high temperatures are generated within the braking system during braking, it is important that the master cylinder reservoir has enough space to allow the fluid to expand. Never overfill the reservoir! Do not fill the reservoir above the maximum level line!

EXPLODED VIEW OF BRAKING SYSTEM

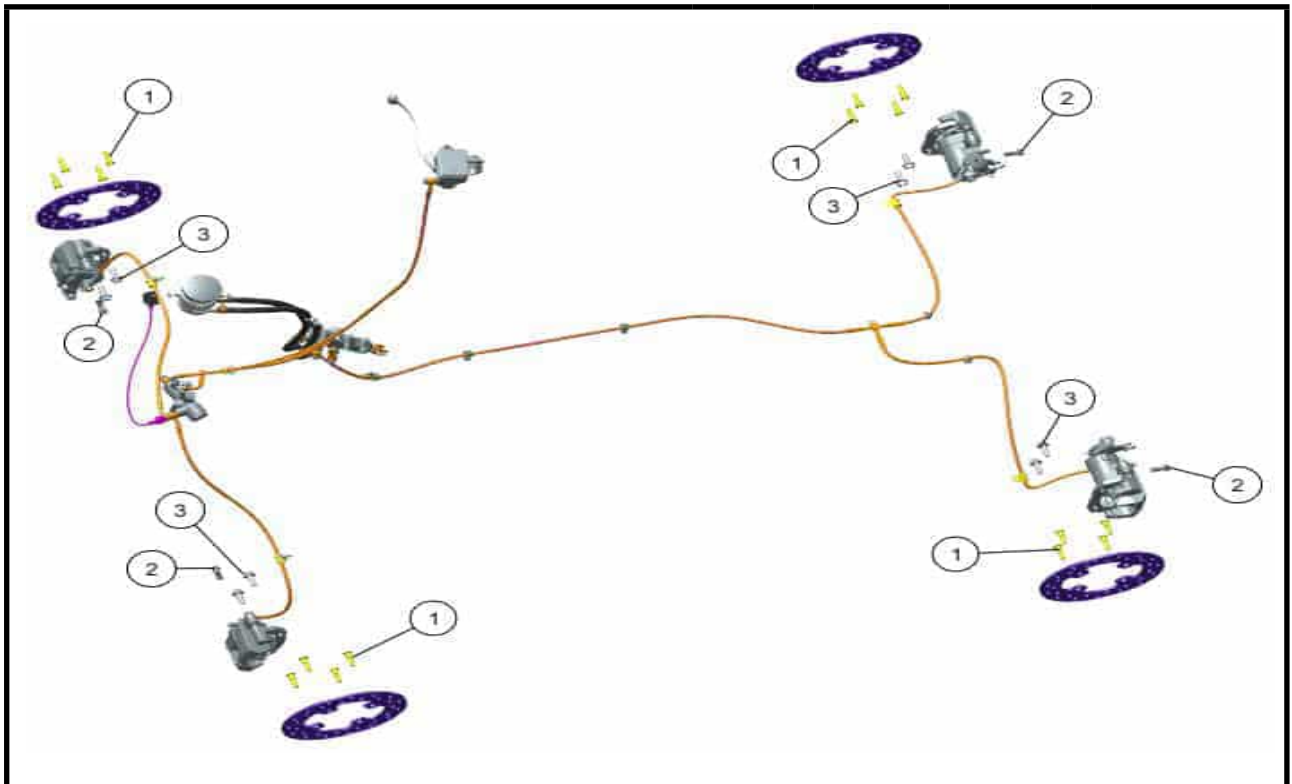

No.	Fastener	Torque			Remarks
		N·m	kgf·m	ft·lb	
1	Brake disc mounting bolts	45	4.5	33	L
2	brake hose mounting bolts	25	2.5	18	
3	Brake fastening bolt	40	4	29	L

L: Use non-permanent locking agent

1. Brake disc bolts, brake main pump bolts, and brake fastening bolts need to be inspected and tightened regularly.
2. The dust cover of the brake sliding rod needs to be coated with silicone oil to ensure flexible movement.

PARKING BRAKE EXPLOSION DIAGRAM

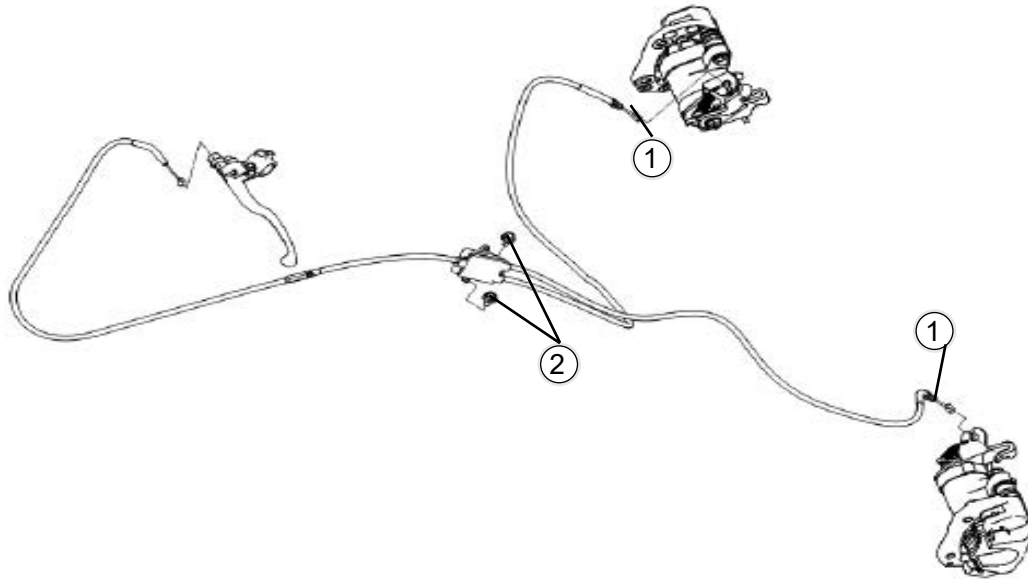

No.	Fastener	Torque			Remarks
		N·m	kgf·m	ft·lb	
1	Parking Brake Lever Screw	8.8	0.9	78in.lb	
2	Junction box fastening bolts	8.8	0.9	78in.lb	

SPECIFICATIONS

Item	Standard	Service Limit
Brake Fluid: Type	DOT 4	---
Front Disc Brake: Pad lining thickness	4.0 mm (0.16 in.)	1.5mm (0.04 in.)
Disc thickness	4.8~5.2mm (0.19~ 0.205 in.)	4 mm (0.16 in.)
Disc runout	TIR 0.08 mm (0.003 in.) or less	TIR 0.1 mm (0.004 in.)
Rear Brake Lever, Pedal and Cables: Rear brake pedal position	35 ~ 40 mm (1.38 ~ 1.57 in.)	---
Rear parking handle working stroke	10~20 mm (0.4~ 0.8 in.)	---
Rear brake pedal working stroke	25~30 mm (1.0~1.2in.)	---

TECHNICAL PARAMETERS

Item	Standard	Use Limit
Brake fluid: type	Total DOT 4	---
Front and rear brake pad parameters: Brake pad thickness	5.0 mm (0.19 in)	1.5 mm (0.06 in)
Front and rear brake disc parameters: Brake disc thickness	4.8~5.2mm (0.19~ 0.205 in)	4 mm (0.16 in)
Brake disc jump	TIR 0.08 mm (0.003 in.) or less	TIR 0.1 mm (0.004 in)
Rear brake pedal: Parking handle working stroke	20~25 mm (0.8~ 0.98in.)	---
Rear brake pedal working stroke	25~30 mm (1.0~1.2in.)	---

SPECIAL TOOLS

circlip pliers

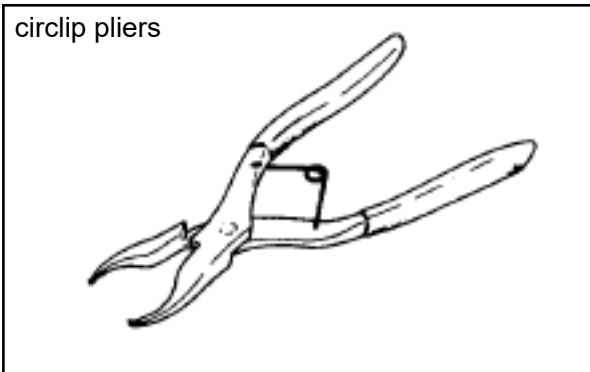

BRAKE FLUID

⚠ WARNING

1. When using disc brakes, please observe the following precautions.
2. 1. Never reuse old brake fluid.
3. 2. Do not use brake fluid that is not sealed or has been opened for a long time.
4. 3. Do not mix two brands of brake fluid. This lowers the boiling point of the brake fluid and may cause the brakes to become ineffective. It may also cause rubber brake components to deteriorate.
5. 4. Do not open the brake fluid reservoir cap for a long time to prevent the brake fluid from being contaminated by moisture.
6. 5. Do not change brake fluid on rainy days or when there is strong wind.
7. 6. Only use isopropyl alcohol or ethanol to clean brake parts except brake pads and discs. Do not use any other liquid to clean these parts
8. point. Gasoline, engine oil, or any other petroleum extract can cause rubber parts to deteriorate. Oil spilled anywhere is difficult to clean completely and will eventually deteriorate the rubber in your disc brakes.
9. 7. When handling the brake pads and brake discs, be careful not to let brake fluid or any oil get on the brake pads and brake discs. Do not use products that leave an oily residue. If it cannot be cleaned, replace the brake pads with new ones.
10. 8. Brake fluid will quickly damage the paint. any spilled fluid should be flushed immediately and completely

BRAKE FLUID REPLACEMENT/BRAKE BLEEDING

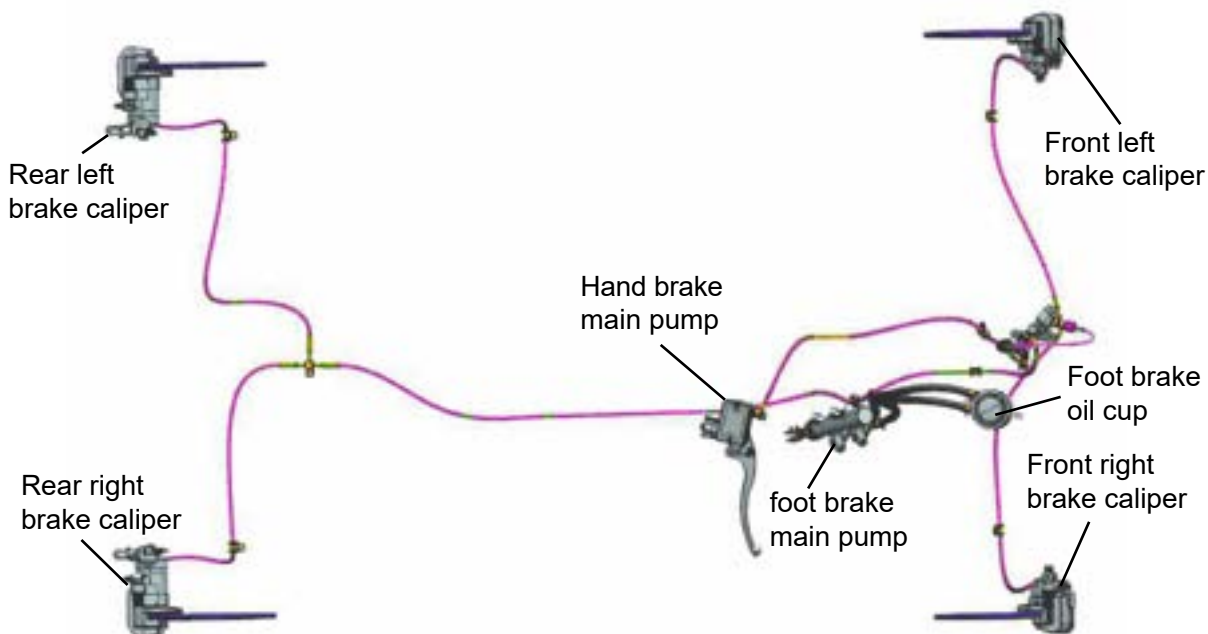

When bleeding your brakes or changing your brake fluid, always start with the caliper furthest from the master cylinder. Use this procedure to change the brake fluid or bleed the brakes during scheduled maintenance.

⚠ WARNING

Always wear safety glasses. Brake fluid can damage the surface of parts. Do not let brake fluid come into contact with the surface of the part.

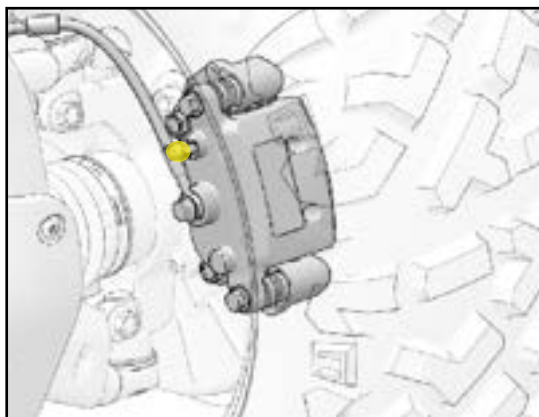
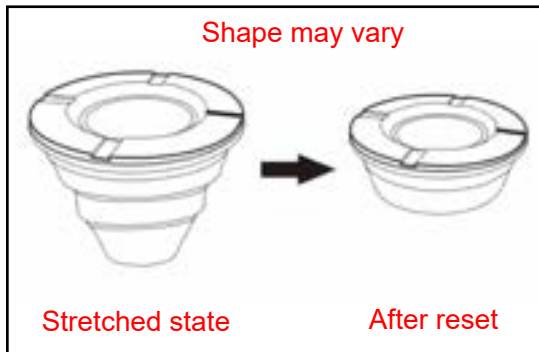
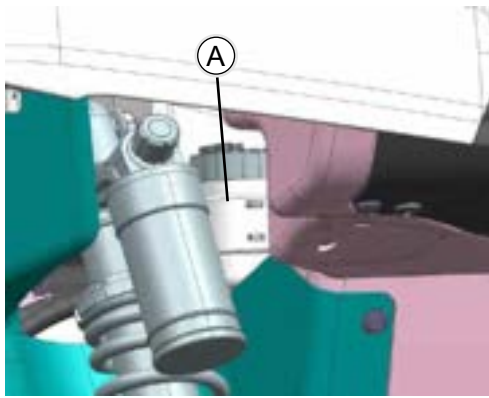

1. The foot brake oil cup **【A】** is located under the front access cover and in front of the front right shock absorber. The fluid level can be observed through the window in front of the front right shock absorber.
2. Remove the cap from the reservoir.
3. If changing the fluid, use a vacuum can or similar tool to drain the brake fluid from the oil cup.
4. Add brake fluid to the maximum reservoir level shown.

⚠ CAUTION

After adding or replacing brake fluid, check whether the oil coaster under the oil cup cover is in an extended state. If the oil coaster is in an extended state, the oil coaster needs to be reset (as shown in the figure). If the oil cup gasket is not reset, the brake fluid will overflow the oil cup when the oil cup cap is tightened.

Brake fluid can damage plastics and painted surfaces, so use caution when adding it.

If brake fluid comes into contact with skin or eyes, please rinse immediately with plenty of water. If you still feel unwell, please seek medical attention immediately.

5. When starting the exhaust procedure, start with the caliper farthest from the master cylinder.
6. Place the open-end wrench on the bleeder screw on the caliper to be bled.
7. Reliably connect one end of the transparent hose to the head of the bleed screw, and place the other end into the waste liquid recovery container to facilitate the recovery of waste liquid.
8. Continuously add new brake fluid to the brake fluid cup, and always ensure that the fluid level in the oil cup is between the "MAX" and "MIN" scale lines.
9. Have your assistant slowly depress the brake pedal until pressure builds up, and then hold it there.
10. Quickly open and close the bleeder screw while maintaining pressure on the brake pedal

⚠ WARNING

Do not release the brake pedal until the bleeder screw is tightened, otherwise air may be sucked into the master cylinder.

11. Release brake pedal pressure. Check the fluid level in the reservoir and add if necessary.
12. Repeat steps 9-11 until the brake pedal is firm and no air can be seen passing through the clear hose. Add fluid as needed to maintain the level in the reservoir.
13. Tighten the bleed screw and remove the bleed hose. Tighten the bleed screw to the specified torque.

Master pump liquid level:
between min and max lines

⚠ CAUTION

Maintain at least a minimum level of brake fluid in the reservoir to prevent air from entering the master cylinder.

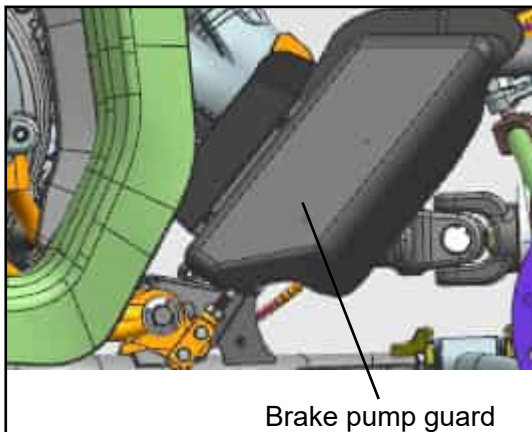

Brake pump guard

14. Repeat steps 9-13 for the remaining brake calipers.
15. Install the master cylinder reservoir cap.
16. Before putting into use, conduct on-site testing of the complete vehicle at low speed. Check that rear brake action and pedal free travel are correct. After firmly stepping on the pedal, the free travel of the pedal should be no less than 1/2" (1.3cm).
17. Check the brake system for oil leakage

FOOT BRAKE MASTER CYLINDER REPAIR

FOOT BRAKE MASTER CYLINDER DISASSEMBLY

- ◆ First remove the brake pump guard plate, and then remove the two hexagonal flange bolts M8×25 **【A】** that fix the master cylinder to the frame.
- ◆ Remove the front access cover **【B】**
- ◆ Remove from above the pin **【C】** and cotter pin **【D】** connecting the master cylinder to the brake pedal lever.
- ◆ Remove the master cylinder and place a waste fluid collecting can under the master cylinder brake line.

⚠ CAUTION

Brake fluid can damage the surface of parts.
Do not let brake fluid come into contact with the surface of the part.

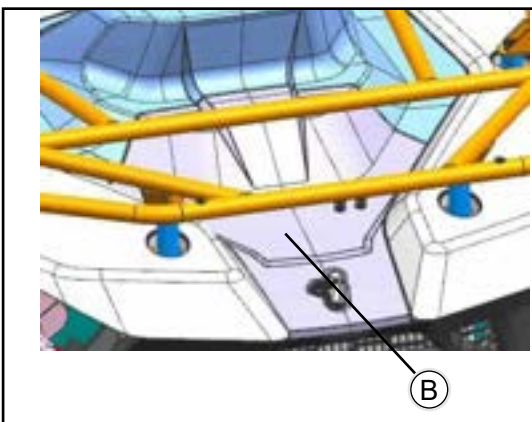

B

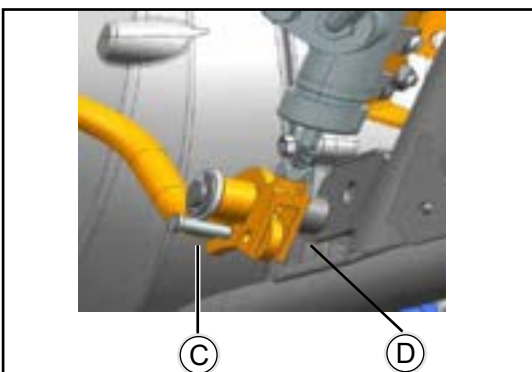

C

D

HANDBRAKE MAIN PUMP BRAKE FLUID FILLING

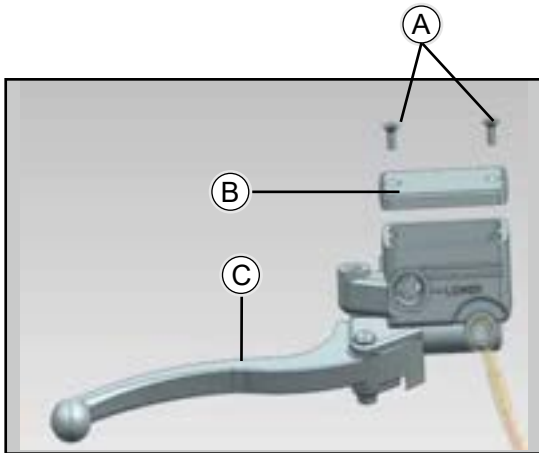

Master pump liquid level:
between the min and max lines.

⚠ CAUTION

Maintain at least a minimum level of brake fluid in the reservoir to prevent air from entering the master cylinder.

1. Oil cup cover fastening screw 【A】
 2. Oil cup cover 【B】
 3. Front brake handle 【C】
- ◆ Before tightening the oil cup cap, the oil cup gasket must be reset.
 - ◆ Before being put into use, conduct field tests on the complete vehicle at low speed. Check whether the front brake action and front brake handle free travel are correct. After the brake handle is pinched and released, the free travel of the brake handle should be no less than 1/2" (1.3cm).
 - ◆ Check the brake system for fluid leaks

FOOT BRAKE MASTER PUMP BRAKE FLUID FILLING

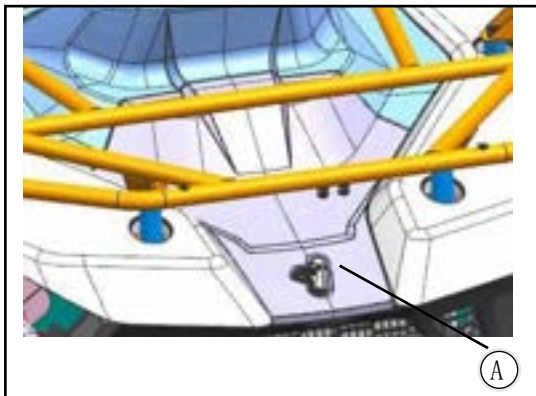

1. Remove the access cover 【A】
 2. Unscrew the foot brake main pump oil cup cap 【B】
- ◆ Before tightening the oil cup cap, the oil cup gasket must be reset.
 - ◆ Check the brake system for fluid leaks.

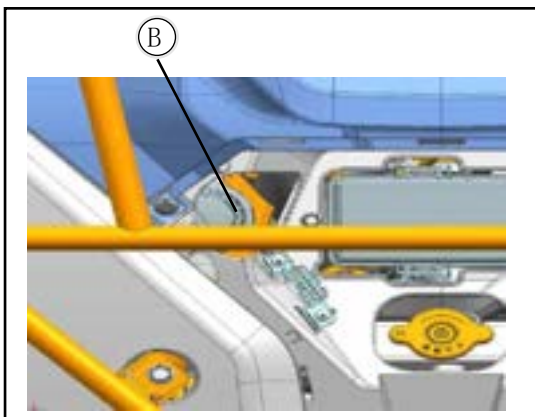

MASTER PUMP INSTALLATION

- ◆ Install the brake line to the master cylinder with a new gasket.
- ◆ Install the brake lines correctly.
- ◆ Tighten the front brake oil pipe **【E】** and rear brake oil pipe **【F】**.

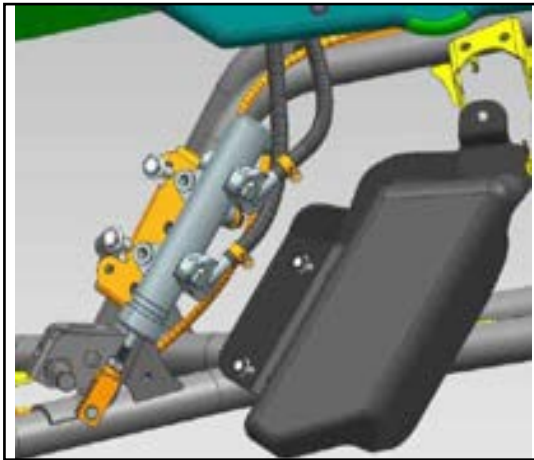

Front and rear brake oil pipe fastening bolts

20 N·m (2 kgf·m, 14.7 ft·lbs)

- ◆ Attach the master cylinder to the frame and tighten the mounting fasteners according to specifications **【A】**

Hexagonal flange bolt M8×25 **【A】**

30 N·m (3.0 kgf·m, 22 ft·lbs)

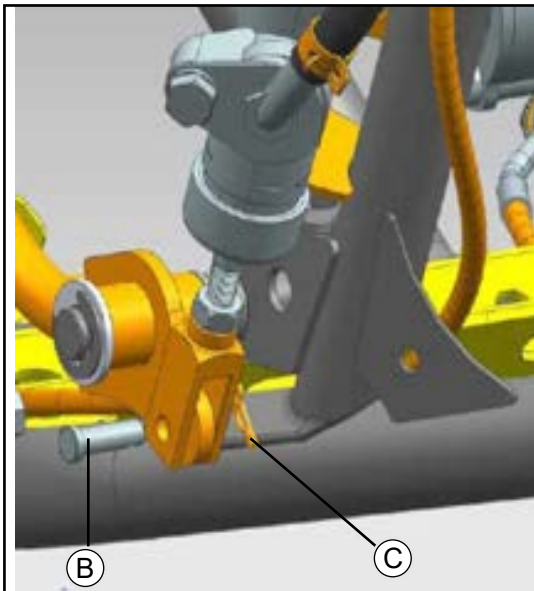

- ◆ Connect the master cylinder to the brake pedal lever by installing pin **【B】** and cotter pin **【C】**.
- ◆ Follow the previous brake fluid change/brake bleeder procedures.
- ◆ Field test the device for proper braking before putting it into use. Check for fluid leaks and brake tightness.

FRONT BRAKE ASSEMBLY

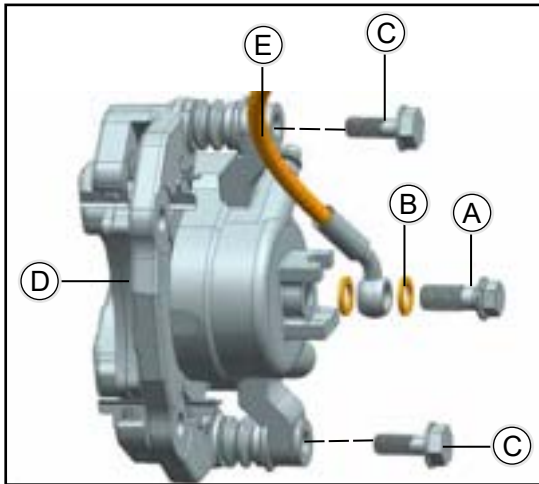

REMOVAL OF FRONT BRAKE ASSEMBLY

- ◆ Removal of front brake assembly
- ◆ Remove the front wheel (see Wheels/Tires section page 9-8).
- ◆ Loosen the fixing bolt 【A】 at the lower part of the brake hose 【E】 , but do not completely remove it yet.
- ◆ Unscrew the brake assembly mounting bolt 【C】 .
- ◆ Remove the brake caliper body assembly 【D】 .

⚠ WARNING

Flush any spilled brake fluid immediately. Brake fluid can damage the surface of parts. Do not let brake fluid come into contact with the surface of the part.

⚠ CAUTION

- ◆ When removing the brake caliper, be careful not to damage the brake lines.
- ◆ Support the brake caliper to avoid kinking or bending the brake lines.

FRONT BRAKE ASSEMBLY INSTALLATION

- ◆ Install the front brake assembly and the lower end of the brake oil pipe.
- ◆ When installing the hose, replace the sealing gaskets on both sides of the brake hose with new ones.
- ◆ Tighten:

Brake assembly mounting bolts

40 N·m (4.0 kgf·m, 29 ft·lbs)

brake hose fixing bolt

25 N·m (2.5 kgf·m, 18.4 ft·lbs)

- ◆ Check the fluid level in the brake fluid cup.
- ◆ Bleed the brake lines.
- ◆ Check whether the brakes have good braking force, there is no drag on the vehicle, and there is no leakage in the brake lines.

⚠ WARNING

Before driving the vehicle, lightly press the brake pedal a few times to make the brake pads and brake discs fit effectively to reduce the idle travel during the initial braking.

- ◆ After the front brake assembly is installed on the vehicle and the pipes are connected, steps 9-11 of brake fluid replacement/brake bleeding are required.

FRONT BRAKE CALIPER BODY

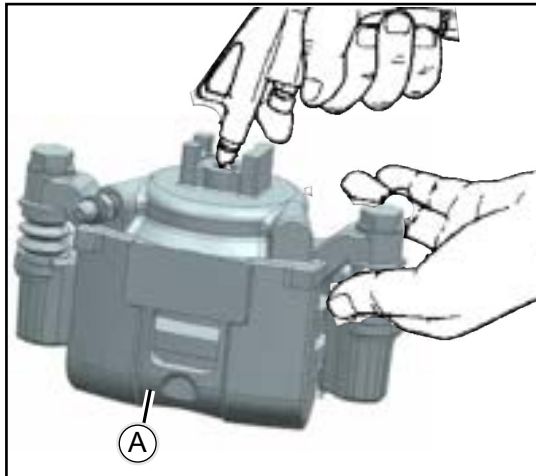

FRONT BRAKE CALIPER BODY REMOVAL

- ◆ Remove the front brake assembly first (see Front Brake Assembly Removal)
- ◆ Remove the brake pad (see front brake pad removal)
- ◆ Using special tools, remove the piston.

Cover the brake caliper housing **【A】** with a clean thick cloth.

Clean the caliper body, piston and retaining bracket with brake cleaner or alcohol.

⚠ WARNING

To avoid serious injury, never place your fingers or palms inside the caliper opening as the piston may crush your hands or fingers.

Make sure the sealing groove of the clamp body is clean.

⚠ CAUTION

If compressed air is not available, follow these steps:

- ◆ Brake hose connected to caliper
- ◆ Prepare brake fluid container
- ◆ Use special tools

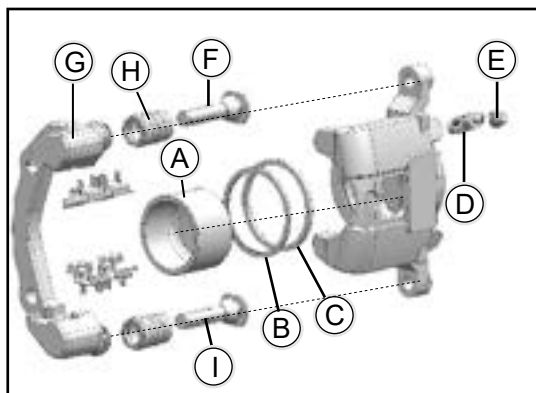

Dismantle in order:

Piston **【A】**

Dust ring **【B】**

Rectangular circle **【C】**

Exhaust nozzle **【D】** and rubber cover **【E】**

Upper guide rod **【F】** and caliper bracket **【G】**

Dust cover **【H】** and lower guide rod **【I】**

FRONT BRAKE CALIPER BODY INSTALLATION

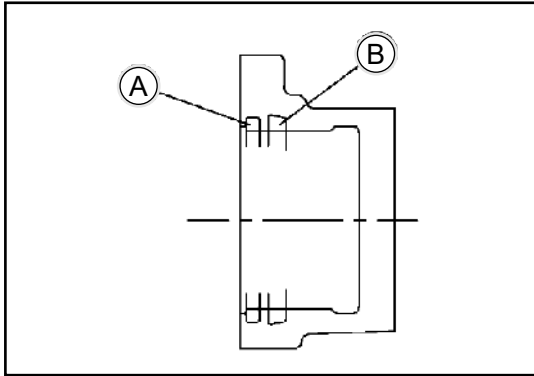

- ◆ Replace with a new rectangular circle **【B】** .
- ◆ Apply a thin layer of silicone grease to the rectangular ring and install it into the brake card
- ◆ Clamp.
- ◆ Replace with new dust ring **【A】** ,
- ◆ Apply a thin layer of silicone grease to the wiper and install it into the brake caliper.

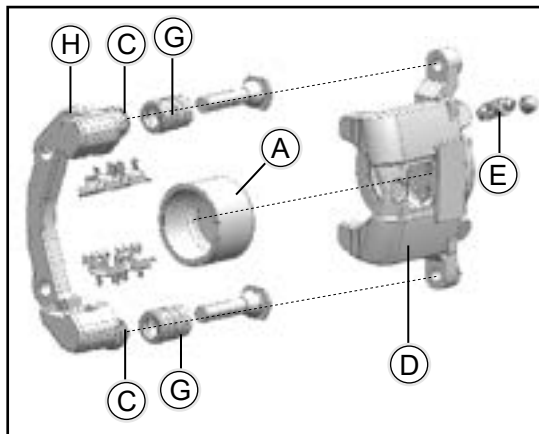

- ◆ Apply a thin layer of silicone grease to the outside of the piston **【F】** and push the piston into the brake caliper **【D】** by hand. Be careful of scratches on the piston and piston skirt.
- ◆ If the dust cover **【G】** is damaged, replace it with a new one.
- ◆ Apply a thin layer of silicone grease to the upper guide rod, lower guide rod and the guide rod installation inner hole **【C】** of the caliper bracket for lubrication (silicone grease is a special high-temperature-resistant and water-resistant grease).
- ◆ Install the caliper bracket **【H】** and exhaust tip **【E】**

Exhaust nozzle **【E】**

7.9 N·m (0.8 kgf·m, 5.8 ft·lbs)

FRONT BRAKE PAD

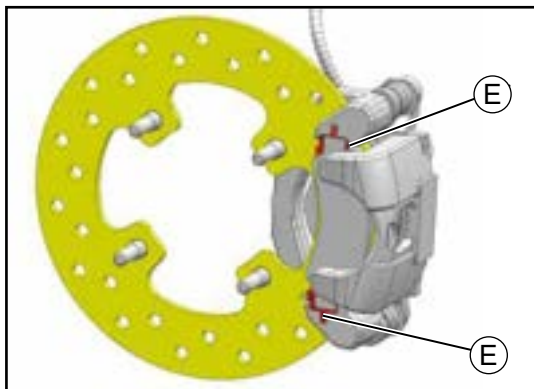
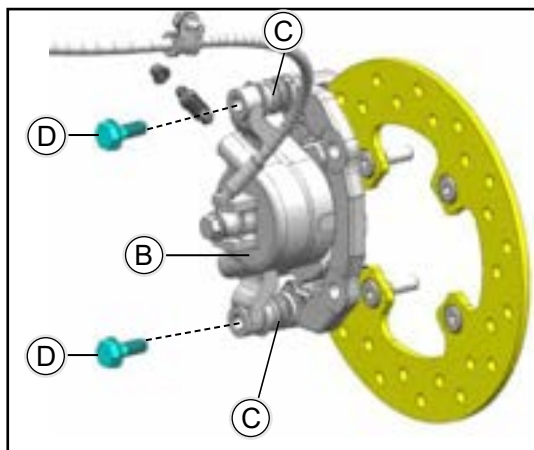
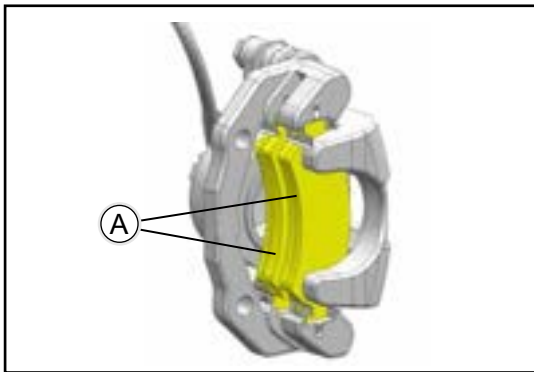

FRONT BRAKE PAD REMOVAL

- ◆ Remove the front rim assembly.
- ◆ Loosen the fastening bolt 【D】 from the front brake assembly guide rod 【C】. During the process of loosening the bolt 【D】, it is required that the head of 【C】 is always in contact with the brake caliper body 【B】. Otherwise, 【C】 will rotate with 【D】 because it is not limited, making 【D】 unable to be disassembled.
- ◆ Rotate the brake caliper body at least 90 degrees so that the brake pad 【A】 can be easily removed from the spring holder 【E】 on the inside and outside of the brake disc.

FRONT BRAKE PAD INSTALLATION

- ◆ Push the caliper piston all the way in with your hand.
- ◆ Install the brake pads in the upper and lower spring holders 【E】 on the inner (or outer) side, and fit them into the brake discs respectively.
- ◆ Unscrew the front brake caliper so that its installation hole coincides with the hole of the brake assembly guide rod 【C】, and the front brake assembly guide rod 【C】 must be limited to the brake caliper 【B】 and aligned with the brake assembly guide rod 【C】. Brake calipers 【B】 fit snugly.
- ◆ Apply thread glue to the newly loosened fastening bolt 【D】.
- ◆ Tighten the caliper mounting bolts 【D】

Caliper mounting bolt 【D】

25N·m(2.5kgf·m, 18 ft·lb)

⚠ WARNING

Do not attempt to drive the vehicle until the brakes are tightened. Braking force is obtained by depressing the brake pedal several times until the brake pads contact each brake disc. If you don't do this, the brakes will not work the first time they are applied.

FRONT BRAKE PAD WEAR INSPECTION

- ◆ Refer to the Brake Pad Maintenance chapter in Scheduled Maintenance

⚠ WARNING

Do not use brake pads if they are contaminated with grease, oil, or soaking fluid. Use only new cleaning pads.

FRONT BRAKE DISC

FRONT BRAKE DISC CLEANING

Poor braking can be caused by dirt on the brake discs. Stains on brake discs must be cleaned with an oil-free cleaning fluid such as trichlorethylene or acetone.

⚠ WARNING

These cleaning fluids are often highly flammable and can be harmful to humans if inhaled over a prolonged period of time. Always heed the manufacturer's warnings.

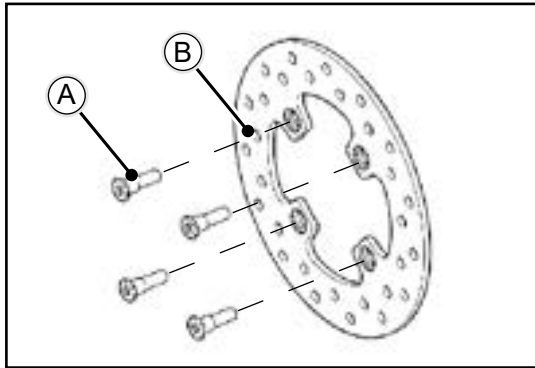

FRONT BRAKE DISC REMOVAL

- ◆ Remove the front wheel hub (see Wheels/Tires chapter pages 9-15)
- ◆ Remove the front brake disc mounting bolt **【A】**
- ◆ Remove the front brake assembly (see Front Brake Assembly Removal)
- ◆ Remove the front brake disc **【B】**

FRONT BRAKE DISC INSTALLATION

- ◆ The front brake disc must be installed with the marked side
- ◆ **【A】** Toward the steering knuckle.
- ◆ Non-permanent locking agents should be used:
- ◆ Tighten:

Brake disc mounting bolts
45 N·m (4.5 kgf·m, 33 ft·lbs)

- ◆ After installing the disc brake rotor, check the front brake rotor for runout. Thoroughly remove any accumulated grease and coat both sides of the disc brake rotor with oil-free solvent. Do not use products that leave an oily residue.

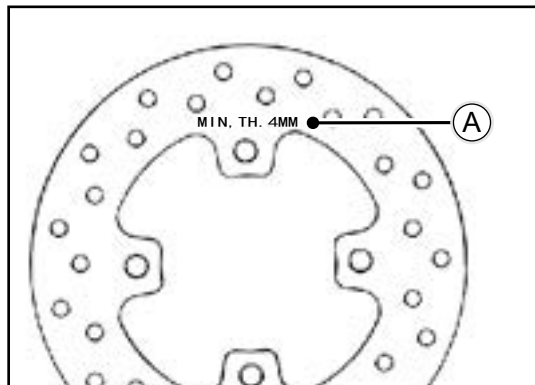

FRONT BRAKE DISC INSPECTION

- ◆ Measure the thickness of each point
- ◆ **【A】** The place with the most wear.
- ◆ If the front brake disc wear exceeds the thickness limit, please replace the brake disc.

Brake disc thickness

Standard thickness:: 4.8~5.2mm (0.19 ~ 0.205 in.)

Maximum thickness : 4mm (0.16 in.)

⚠ WARNING

Be sure to use new brake disc mounting bolts. Bolts come with pre-applied locking compound that is destroyed when disassembled.

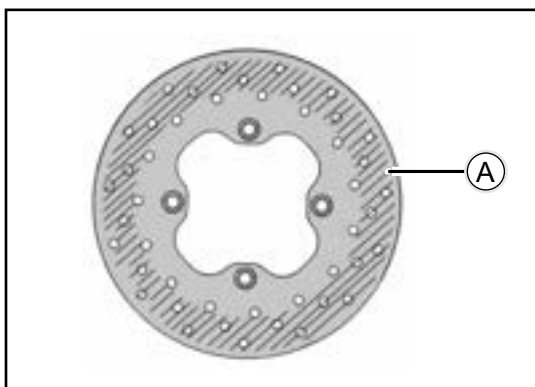

REAR BRAKE ASSEMBLY

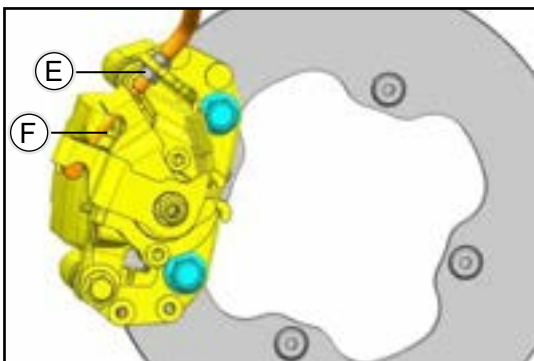
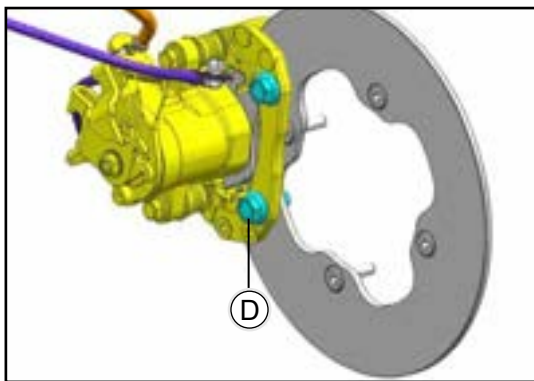
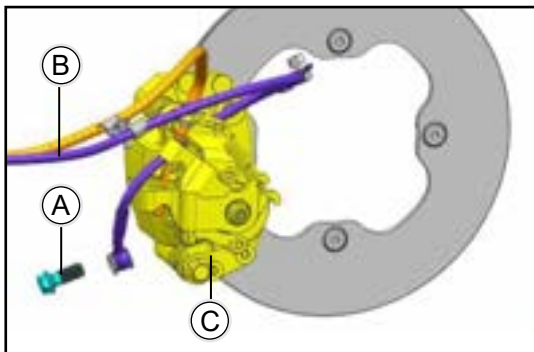

REAR BRAKE ASSEMBLY REMOVAL

- ◆ Remove the rear wheel (see Wheels/Tires section).
- ◆ Loosen the fixing bolt **【A】** of the brake hose **【B】** without completely removing it yet.
- ◆ Loosen the two mounting bolts **【D】** of the rear brake assembly.
- ◆ Loosen the parking cable bolt **【E】** and remove the parking cable assembly **【F】** from the brake.
- ◆ Remove the rear brake caliper body assembly **【C】**

⚠ WARNING

Flush any spilled brake fluid immediately. Brake fluid can damage the surface of parts. Do not let brake fluid come into contact with the surface of the part.

⚠ CAUTION

When removing the brake caliper, be careful not to damage the brake lines.

Support the brake caliper to avoid kinking or bending the brake lines.

REAR BRAKE ASSEMBLY INSTALLATION

- ◆ Install the rear brake assembly, brake oil pipe and parking oil pipe.
- ◆ When installing the hose, replace the sealing gaskets on both sides of the brake hose with new ones.
- ◆ Tighten:

Brake assembly mounting bolts

40 N·m (4.0 kgf·m, 29 ft·lbs)

brake hose fixing bolt

25 N·m (2.5 kgf·m, 18.4 ft·lbs)

- ◆ Check the fluid level in the master cylinder oil cup.
- ◆ Bleed the brake lines.
- ◆ Check whether the brakes have good braking force, there is no drag on the vehicle, and there is no leakage in the brake lines.

⚠ WARNING

Before driving the vehicle, lightly press the brake pedal a few times to make the brake pads and brake discs fit effectively to reduce the idle travel during the initial braking.

- ◆ After the rear brake assembly is installed on the vehicle and the pipeline is connected, steps 9-11 of brake fluid replacement/brake bleeding are required.

REAR BRAKE CALIPER BODY

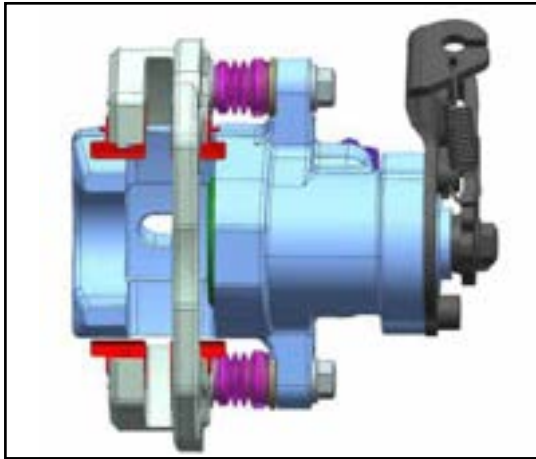

REAR BRAKE CALIPER BODY REMOVAL

- ◆ Remove the rear brake assembly first (see Brake Assembly Removal 11-6)
- ◆ Remove the rear brake pad (see Rear Brake Pad Removal)
- ◆ Using special tools, remove the piston.

Cover the brake caliper housing **【A】** with a clean thick cloth.

Clean the caliper body, piston and retaining bracket with brake cleaner or alcohol.

⚠ WARNING

To avoid serious injury, never place fingers or palms inside caliper openings.

This prevents the piston from crushing your hands or fingers.

Make sure the sealing groove of the clamp body is clean.

⚠ CAUTION

If compressed air is not available, follow these steps:

- ◆ Brake hose connected to caliper
- ◆ Prepare brake fluid container
- ◆ Use special tools

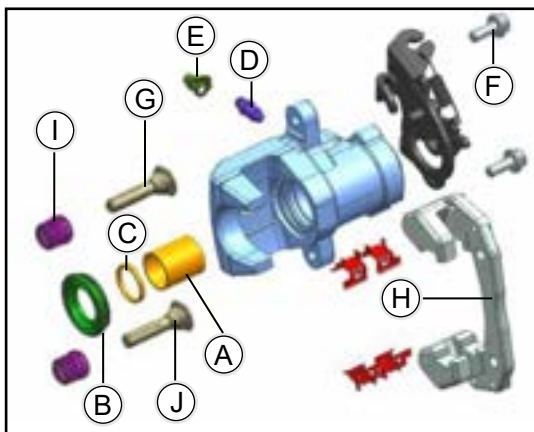

Dismantle in order:

Piston **【A】**

Dust ring **【B】**

Rectangular circle **【C】**

Exhaust nozzle **【D】** and rubber cover **【E】**

Hexagonal flange bolt M8*20 **【F】**

Upper guide rod **【F】** and caliper bracket **【H】**

Dust cover **【I】** and lower guide rod **【J】**

REAR BRAKE CALIPER BODY INSTALLATION

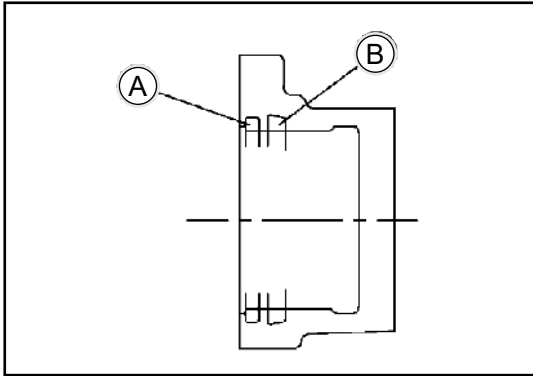

- ◆ Replace with a new rectangular circle **【B】** .
- ◆ Apply a thin layer of silicone grease to the rectangular ring and install it into the rear brake caliper.
- ◆ Replace with new dust ring **【A】** ,
- ◆ Apply a thin layer of silicone grease to the wiper and install it into the rear brake caliper.

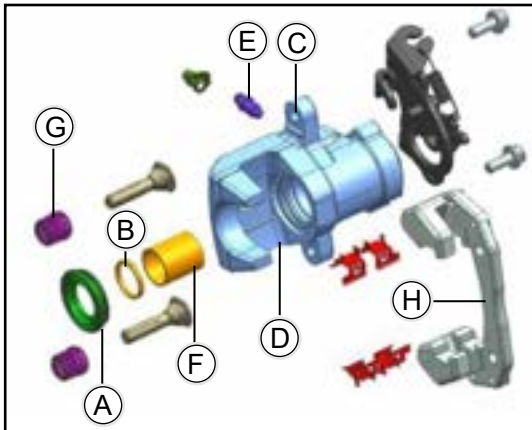

- ◆ Apply a thin layer of silicone grease to the outside of the piston **【F】** and push the piston into the brake caliper **【D】** by hand. Be careful of scratches on the piston and piston skirt.
- ◆ If the dust cover **【G】** is damaged, replace it with a new one.
- ◆ Apply a thin layer of silicone grease to the upper guide rod, lower guide rod and the guide rod installation inner hole **【C】** of the caliper bracket for lubrication (silicone grease is a special high-temperature-resistant and water-resistant grease).
- ◆ Install the caliper bracket **【H】** and exhaust tip **【E】**

Exhaust nozzle **【E】**

7.9 N·m (0.8 kgf·m, 5.8 ft·lbs)

REAR BRAKE PAD

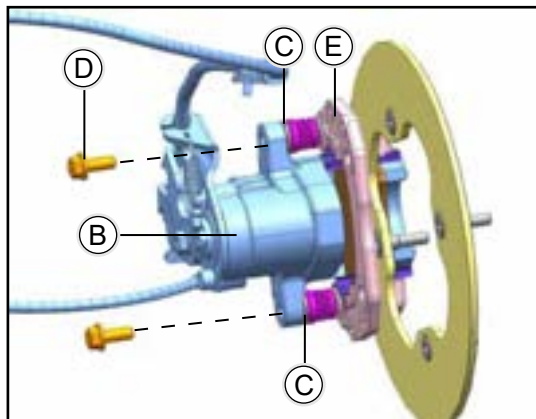
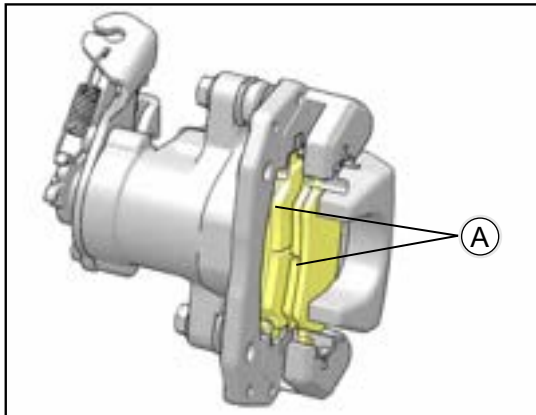

REAR BRAKE PAD REMOVAL

Remove the rear rim assembly or rear rim assembly.

- ◆ Loosen the fastening bolt 【D】 from the brake assembly guide rod 【C】. During the process of loosening the bolt 【D】, it is required that the head of 【C】 is always in contact with the brake caliper body 【B】. Otherwise, 【C】 will rotate with 【D】 because 【C】 is not limited, making 【D】 unable to be disassembled.
- ◆ Rotate the brake caliper body at least 90 degrees so that the brake pad 【A】 can be easily removed from the spring holder 【E】 on the inside and outside of the brake disc.

REAR BRAKE PAD INSTALLATION

- ◆ Push the caliper piston all the way in with your hand.
- ◆ Install the brake pads in the upper and lower spring holders 【E】 on the inner (or outer) side, and fit them into the brake discs respectively.
- ◆ Unscrew the brake caliper so that its installation hole coincides with the hole of the brake assembly guide rod 【C】, and the brake assembly guide rod 【C】 must be limited to the brake caliper 【B】 and aligned with the brake caliper 【B】. Caliper 【B】 fits.
- ◆ Apply thread glue to the newly loosened fastening bolt 【D】.
- ◆ Tighten the caliper mounting bolts □D□

Caliper mounting bolt □D□

25N·m(2.5kgf·m,18 ft·lb)

⚠ WARNING

Do not attempt to drive the vehicle until the brakes are tightened. Braking force is obtained by depressing the brake pedal several times until the brake pads contact each brake disc. If you don't do this, the brakes will not work the first time they are applied.

REAR BRAKE PAD WEAR INSPECTION

- ◆ Refer to the Brake Pad Maintenance chapter in Regular Maintenance

⚠ WARNING

If the brake pads are contaminated with grease, oil or soaking fluid, do not use brake pads. Use only new cleaning pads.

REAR BRAKE DISC

REAR BRAKE DISC CLEANING

Poor braking can be caused by dirt on the brake discs. Stains on brake discs must be cleaned with an oil-free cleaning fluid such as trichlorethylene or acetone.

⚠ WARNING

These cleaning fluids are often highly flammable and can be harmful to humans if inhaled over a prolonged period of time. Always heed the manufacturer's warnings.

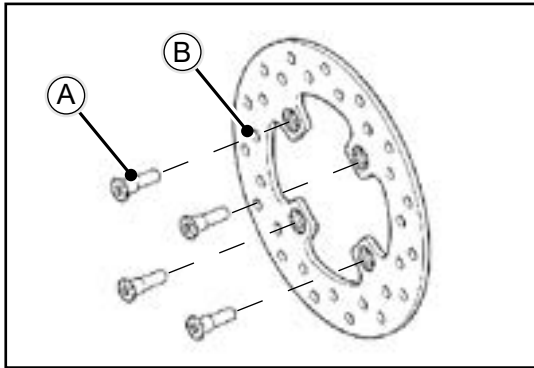

REAR BRAKE DISC REMOVAL

- ◆ Remove the rear hub (see Wheels/Tires section)
- ◆ Remove the rear brake disc mounting bolt **【A】**
- ◆ Remove the rear brake assembly (see Rear Brake Assembly Removal)
- ◆ Remove the rear brake disc **【B】**

REAR BRAKE DISC INSTALLATION

- ◆ Brake discs must be installed with the marked side
- ◆ **【A】** Toward the steering knuckle.
- ◆ Non-permanent locking agents should be used:
- ◆ Tighten:

Brake disc mounting bolts

45 N·m (4.5 kgf·m, 33 ft·lbs)

- ◆ After installing the disc brake disc, check the disc brake disc runout. Thoroughly remove any accumulated grease and coat both sides of the disc brake rotor with oil-free solvent. Do not use products that leave an oily residue.

REAR BRAKE DISC INSPECTION

- ◆ Measure the thickness of each point
- ◆ **【A】** The place with the most wear.
- ◆ If the rear brake disc is worn beyond the thickness limit, please replace the rear brake disc.

Brake disc thickness

Brake disc standard thickness: 4.8~5.2mm (0.19~0.205 in.)

Brake disc maximum thickness: 4 mm (0.16 in.)

⚠ WARNING

Be sure to use new brake disc mounting bolts. Bolts come with pre-applied locking compound that is destroyed when disassembled.

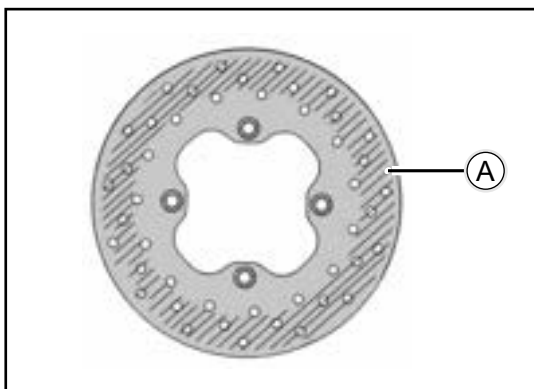
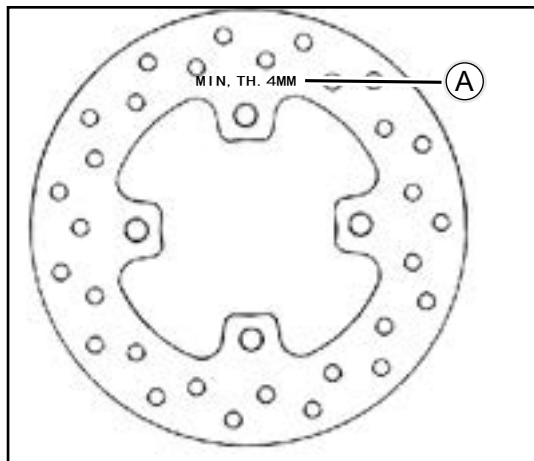

BRAKE HOSES

BRAKE HOSE INSPECTION

- ◆ Refer to the Brakes in the Periodic Maintenance chapter.
- ◆ Brake Hose Replacement
- ◆ Refer to the Brakes in the Periodic Maintenance chapter.

REAR BRAKE PEDAL

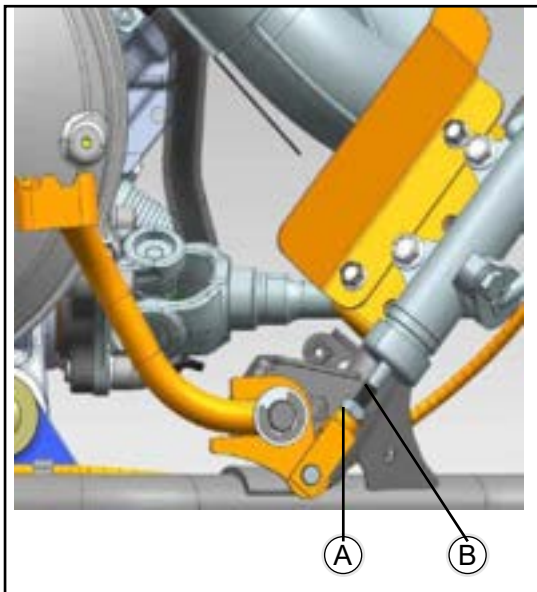

BRAKE PEDAL POSITION ADJUSTMENT

- ◆ Loosen the locknut **【A】** , and turn the adjusting bolt **【B】** until the brake pedal is correctly positioned.
- ◆ Tighten the locknut.
- ◆ Check the brake pedal free play .

REAR BRAKE PEDAL REMOVAL

- 【A】** Brake pedal
- 【B】** Retaining ring
- 【C】** Large flat pad
- 【D】** Brake pedal flanged bushing
- ◆ Use pliers to remove the retaining ring **【B】**
- ◆ Remove the large flat pad **【C】**
- ◆ Remove the brake pedal **【A】** assembly
- ◆ Remove Remove piece **【D】** from the brake pedal

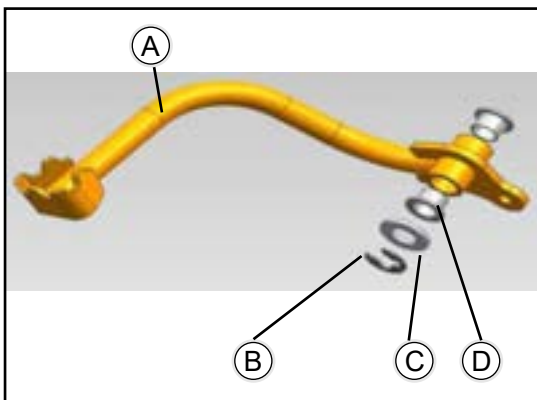

INSTALLATION OF REAR BRAKE PEDAL

Grease the end of the brake pedal shaft.

- ◆ Install the 2 pieces of brake pedal flange bushing **【D】** into the brake pedal **【A】**
- ◆ Install the large flat pad **【C】**
- ◆ Then install the elastic retaining ring **【B】** in place.

PARKING CABLE

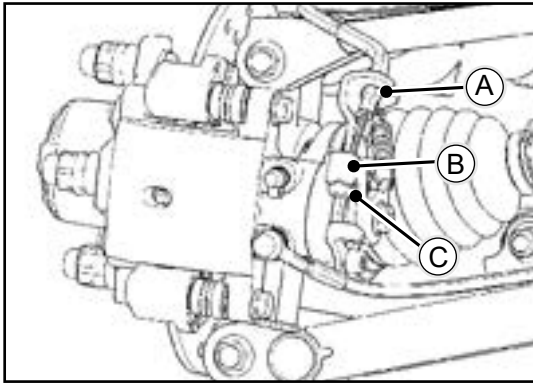

PARKING CABLE REMOVAL

- ◆ Take the parking cable head 【C】 out of the swivel arm 【B】 in the rear brake.
- ◆ Disassemble 2 pieces of M8 nuts 【A】 .
- ◆ Loosen the knurled locknut 【E】 on the parking handle and screw in the adjuster 【F】 .
- ◆ Align the slot 【D】 in the parking handle with the knurled lock nut and adjust card slot.
- ◆ Remove the parking cable from the parking handle.

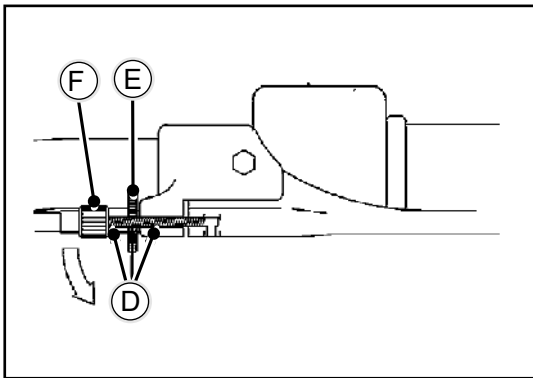

INSTALLATION OF PARKING CABLE

Follow the reverse order of the "Parking Cable Removal" above to complete the installation of the parking cable.

BRAKE SYSTEM TROUBLESHOOTING

TROUBLESHOOTING BRAKE NOISE

Dirt or dust buildup on the brake pads and discs is the most common cause of brake noise (squealing caused by vibration).

It is necessary to strengthen the cleaning of the contact surfaces of the brake pads and the brake discs to reduce the noise caused by dust or other particles existing between the two working surfaces.

TROUBLESHOOTING BRAKE NOISE

Reason	Solution
Dirt, dust or embedded material on the pad or disc	Non-flammable aerosol brake cleaner. Remove the brake pad and/or brake disc hub seat to clean the embedded material on the brake pad or disc.
Brake pad dragging on brake disc (noise or premature pad wear), Because of improper adjustment Master pump reservoir overfilled Master cylinder compensation port is restricted The master cylinder piston does not return completely Brake caliper piston does not return Operator error (brake applied)	Adjust pad stop set to appropriate level Clean compensation port Check. Repair if necessary Clean piston seals Education Operator
Loose wheel hub or bearing	Check the wheels and hubs for any unusual movement.
Brake discs are warped or excessively worn	Replace brake disc
Brake discs are misaligned or loose	Inspect and repair when necessary
Noise coming from other sources (axle, hub, brake disc or wheel)	If the noise does not change when braking, check for other sources. Inspect and repair when necessary

Brake squealing/poor braking performance, please check the following components or systems

- ◆ air intake system
- ◆ There is water in the system (brake fluid is contaminated)
- ◆ Caliper/disc misalignment
- ◆ Dirty or damaged calipers
- ◆ Damaged brake line or broken brake pad
- ◆ Worn brake discs and/or friction pads
- ◆ Improper adjustment of fixed pad
- ◆ Worn or damaged master cylinder or components
- ◆ Damaged brake pad sound insulation material

Pedal vibration, please check the following components or systems

- ◆ Damaged brake disc
- ◆ Brake disc wear (runout or thickness change beyond service limit)

Caliper overheating (brake resistance), please check the following components or systems

- ◆ Compensation port clogged
- ◆ Brake pad gap setting is incorrect
- ◆ Brake pedal is stuck or won't return all the way
- ◆ Residue buildup under caliper seal
- ◆ Driver high frequency service brake

Brake drag, please check the following components or systems

- ◆ Alignment of calipers and brake discs
- ◆ caliper piston stuck
- ◆ Improper assembly of brake system components

STEERING SYSTEM

EXPLODED VIEW OF STEERING SYSTEM	12-2
STEERING WHEEL	12-4
STEERING WHEEL FOLDING	12-4
STEERING WHEEL INSTALLATION	12-4
STEERING COLUMN	12-5
STEERING COLUMN REMOVAL	12-5
STEERING COLUMN MOUNTING	12-5
EPS	12-6
EPS TOTAL DISASSEMBLY	12-6
EPS ASSEMBLY MOUNTING	12-6
STEERING TIE ROD.....	12-7
STEERING ROD FOLDING	12-7
STEERING TIE ROD INSTALLATION	12-7

EXPLODED VIEW OF STEERING SYSTEM

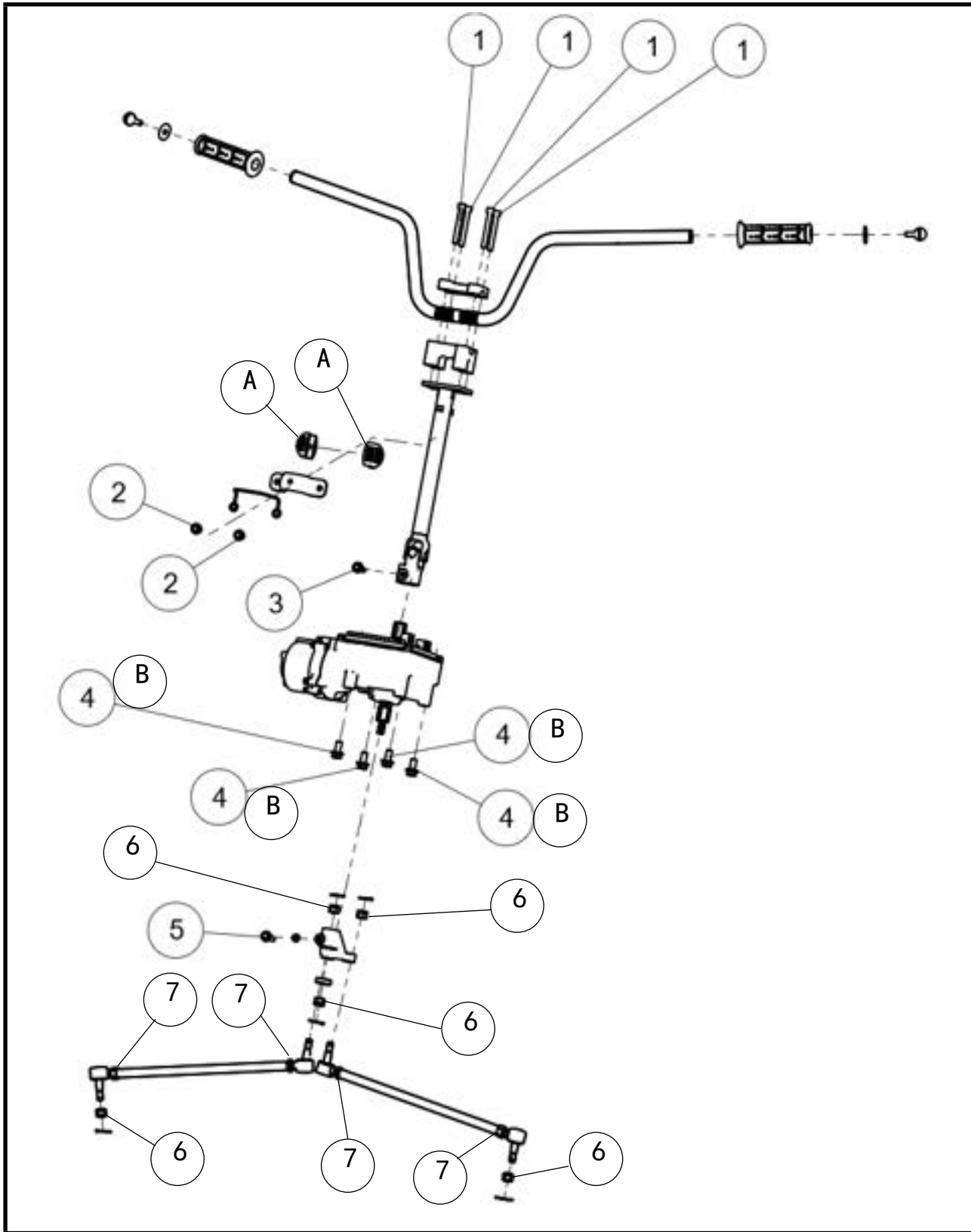

No.	Fastener	Torque			Remarks
		N·m	kgf·m	ft·lb	
1	Hexagon socket cheese head screws M8×65	35	3.6	25.8	
2	Hexagonal flange face bolts M8×16	35	3.6	25.8	
3	Hexagonal flange face bolts M8×30	35	3.6	25.8	
4	Hexagonal flange face bolts M10×1.5×20	45	4.6	33.2	
5	Hexagonal flange face bolts M8×35	35	3.6	25.8	10.9
6	1Hexagon slotted nuts type 1 M10	45	4.6	33.2	
7	Hexagon nuts type 1 M12×1.25	55	5.6	40.5	

A: grease.

B: Apply a non-permanent locking agent

STEERING WHEEL

STEERING WHEEL FOLDING

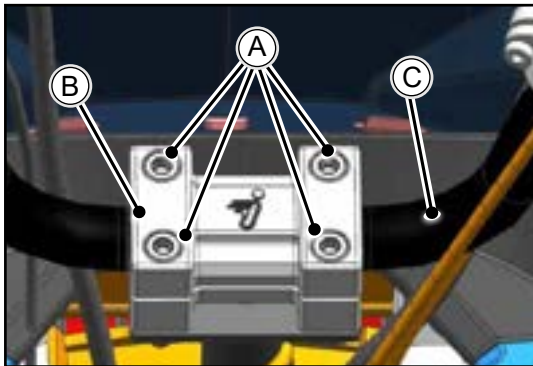

- 【A】 locking bolt
- 【B】 Steering handle gland
- 【C】 steering wheel
- ◆ Handlebar locking bolt 【A】 loose
- ◆ Take off the handlebar gland 【B】 .
- ◆ Remove the steering wheel 【C】 .

STEERING WHEEL INSTALLATION

⚠ CAUTION

Install the steering handle so that the angle of the steering handle matches the angle of the steering column, keeping it parallel. parallel to the steering column, as shown in the figure on the left.

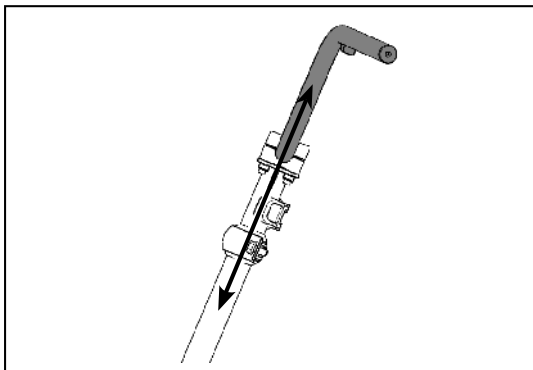

- 【A】 Steering Wheel Lower Gland
- 【B】 locking bolt
- 【C】 locking bolt
- 【D】 clearance

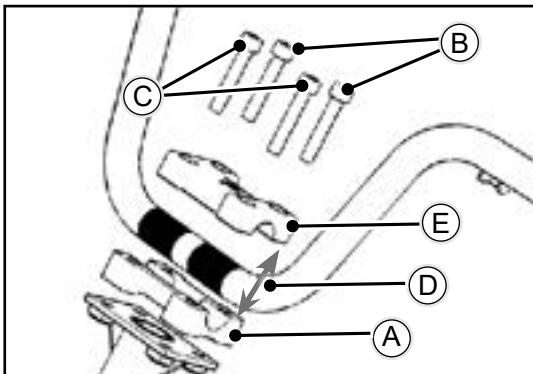

- 【E】 Steering handle gland
- ◆ Place the steering handle lower gland 【A】 on the steering column with the holes aligned
- ◆ Centre the steering wheel in the lower cover of the steering wheel, cover the upper cover of the steering wheel 【E】 , align the holes with the lower cover.
- ◆ Tighten the front locking bolts 【B】 , and then tighten the rear locking bolts 【C】 .

Locking bolt torque
35 N·m (3.5 kgf·m, 25 ft·lb)

⚠ CAUTION

If the locking bolts are installed in the wrong order it will cause the gap between the top and bottom cover to be 【D】 uneven

STEERING COLUMN

STEERING COLUMN REMOVAL

First remove the instrument housing cover and the left front upper inner fender, see Body Disassembly section

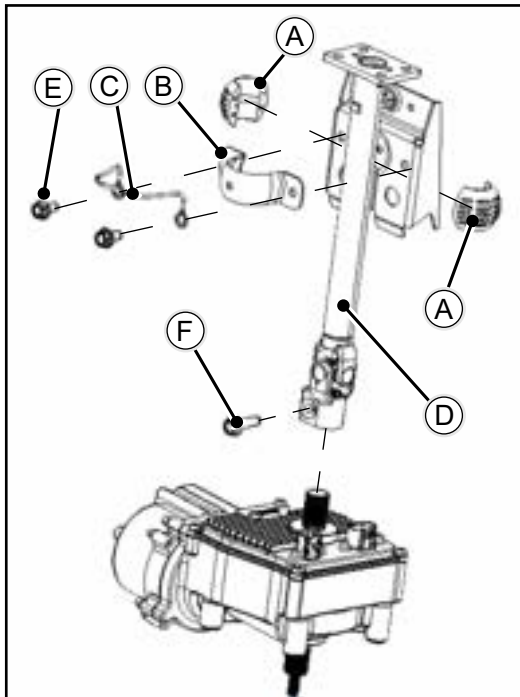

- 【A】 Steering Spherical Seat
- 【B】 Spherical seat locking plate
- 【C】 Wire Harness Storage Wire
- 【D】 Steering Column Assembly
- 【E】 Bolt M8×16
- 【F】 Bolt M8×30

- ◆ Remove 2 hexagonal flange face bolts M8 x 16 【E】
- ◆ Remove the wire harness stowage wire 【C】 , rotating spherical seat locking plate 【B】 and rotating spherical seat 【A】 . Rotating sphere seat 【A】
- ◆ Remove two hexagon flange bolts (half thread) M8×30 【F】
- ◆ Pull out the steering column assembly 【D】

STEERING COLUMN MOUNTING

Install in reverse order of steering column removal

⚠ CAUTION

If the locking bolt spline groove left figure 【G】 position is not aligned will result in bolt rotten teeth and incorrect directional grip.

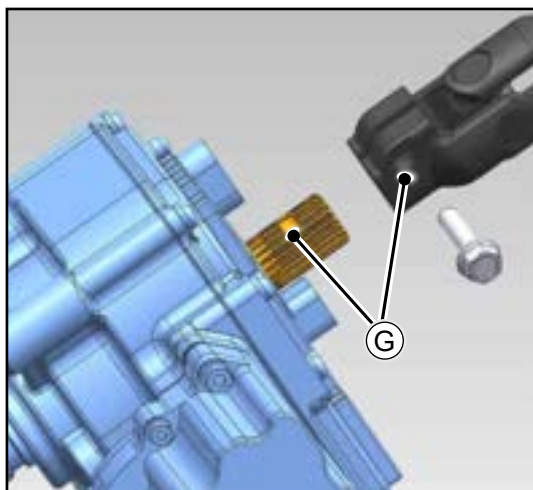

Bolt M8×16/Bolt M8×30 Torque
35 N·m (3.5 kgf·m, 25 ft·lb)

EPS

EPS TOTAL DISASSEMBLY

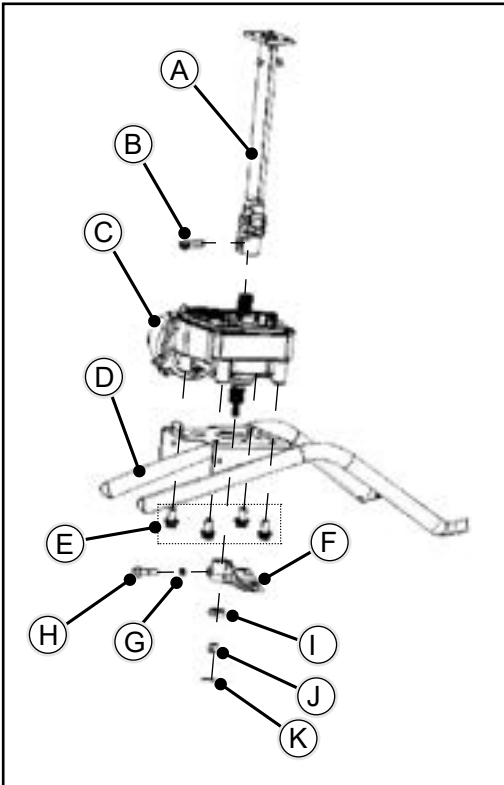

【A】 Steering Column Assembly

【B】 Bolt M8×30

【C】 EPS assembly

【D】 chassis

【E】 Bolt M10×1.5×20

【F】 Steering rocker arm

【G】 Spring washers 8

【H】 Bolt M8×35

【I】 Steering rocker arm spacer

【J】 Slotted nut M10

【K】 cotter pin

- ◆ Disconnect the power to the whole vehicle and remove the connector on the EPS assembly 【C】 .
- ◆ Remove hexagonal flange face bolts M8 x 30 【B】
- ◆ Pull the steering column assembly 【A】 upwards and separate it from the EPS assembly 【C】 .
- ◆ Remove cotter pin 【K】 , slotted nut M10 【J】 and steering rocker arm spacer 【I】 in turn. arm spacer 【I】 .
- ◆ Remove bolt M8 x 35 【H】 and spring washer 8 【G】 .
- ◆ Remove the steering rocker arm 【C】
- ◆ Remove 4 bolts M10 x 1.5 x 20 【E】 .
- ◆ Remove the EPS assembly 【C】

⚠ CAUTION

Be careful not to operate with electricity during disassembly or installation, and protect the EPS connector to avoid damage to the EPS. EPS from being damaged.

Bolt M8×16/Bolt M8×30 Torque

35 N·m (3.5 kgf·m, 25 ft·lb)

EPS ASSEMBLY MOUNTING

Install in reverse order of EPS assembly removal.

STEERING TIE ROD

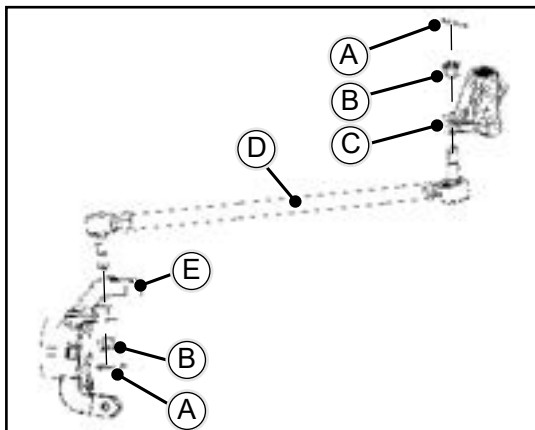

STEERING ROD FOLDING

- 【A】 cotter pin
- 【B】 Slotted nut M10
- 【C】 Steering rocker arm
- 【D】 Tie rods
- 【E】 knuckle

◆ 拆下开口销【A】和开槽螺母M10【B】

◆ Remove the steering tie rods 【D】 from the steering rocker arms 【C】 and steering knuckles 【E】.

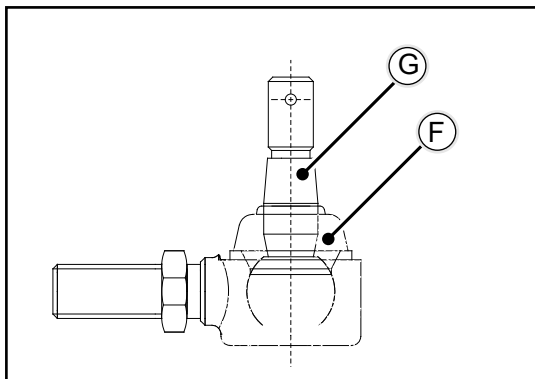

⚠ WARNING

取转向拉杆时注意保护球头螺纹及防尘罩，以免损坏。

STEERING TIE ROD INSTALLATION

Install in reverse order of steering tie rod removal.

⚠ WARNING

Do not remove the dust cover 【F】 , which is filled with grease.

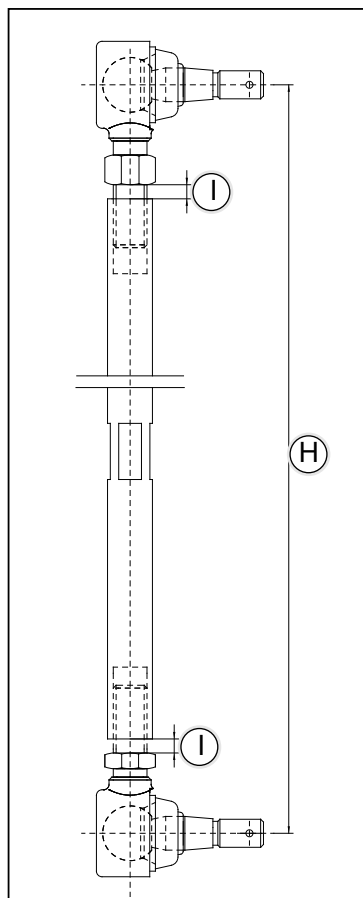

The small end of the taper on the steering tie rod is mounted towards the steering knuckle and steering rocker arm taper holes. The cross tie rod has the correct length 【H】 and the two visible thread lengths 【I】 are approximately equal. Steering tie rod length 【H】 398 ± 1.5 mm.

BODY AND FRAME

EXPLOSION DIAGRAM OF FRONT EXTERIOR TRIM	13-2
EXPLOSION DIAGRAM OF MIDBODY EXTERIOR TRIM	13-4
EXPLOSION DIAGRAM OF REAR EXTERIOR TRIM	13-6
EXPLOSION DIAGRAM OF UNDERBODY EXTERIOR TRIM	13-7
FRONT SHELF COVER.....	13-8
REAR SHELF COVER.....	13-8
CUSHION REMOVAL.....	13-8
MOUNTING CUSHION	13-8
FRONT SERVICE COVER REMOVED	13-8
PRE-INSTALLATION SERVICE COVER	13-8
AIR FILTER COVER REMOVED	13-9
MOUNTING CUSHION	13-9
FRAME BOTTOM MAINTENANCE COVER REMOVED	13-9
MOUNTING CUSHION	13-9
REMOVE THE RIGHT GUARD PLATE	13-9
MOUNTING CUSHION	13-9
ENGINE DISASSEMBLY EXPLOSION DIAGRAM	13-10
DISASSEMBLY	13-11
FRONT AND REAR AXLE DISASSEMBLY EXPLOSION DIAGRAM	13-15
DISASSEMBLY	13-16
ASSEMBLY	13-16
FRONT AXLE MAINTENANCE	13-16
REAR AXLE MAINTENANCE	13-17
DISASSEMBLY	13-17
ASSEMBLY	13-17
FRONT AND REAR SHELF DISASSEMBLY EXPLOSION DIAGRAM	13-18
FRAME ACCESSORY EXPLOSION DIAGRAM	13-19
FRAME ACCESSORY REMOVED	13-20
FRONT BUMPER EXPLOSION DIAGRAM	13-21
FRONT BUMPER REMOVAL	13-22

EXPLOSION DIAGRAM OF FRONT EXTERIOR TRIM



No.	Fastener	Torque			Remarks
		N·m	kgf·m	ft·lb	
1	Instrument panel				
2	Cross recessed pan head tapping screw ST4.2x16				
3	M6 nut clamp				
4	Meter cover				
5	Hexagon flange bolts M6x16	8~12	0.8~1.2	69~103.6 in·lb	

6	Large pan head hexagon bolt M6x16	8~12	0.8~1.2	69~103.6 in·lb	
7	Meter mounting support				
8	Front fender				
9	Front access cover				
10	Expansion buckle components				
11	Left front inner fender				
12	Waist type I-shaped rubber ring				
13	Left headlamp tail cover				
14	Right front inner fender				
15	Brake pump guard plate				
16	headlight mask				
17	front decorative mesh				
18	Front shelf support assembly				

EXPLOSION DIAGRAM OF MIDBODY EXTERIOR TRIM

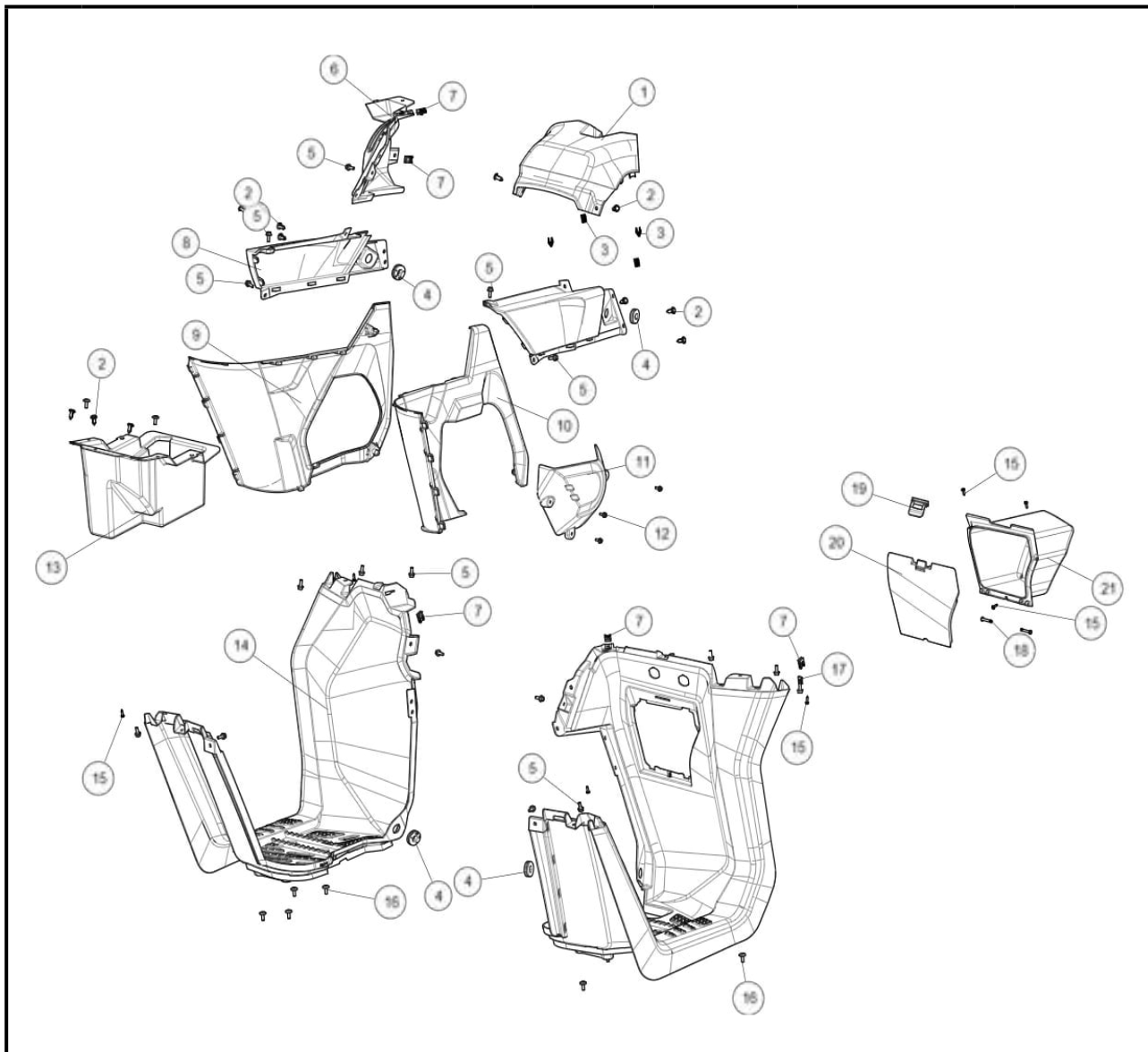

No.	Fastener	Torque			Remarks
		N·m	kgf·m	ft·lb	
1	Air filter cover				
2	Expansion buckle components				
3	Spring buckle				
4	Waist type I-shaped rubber ring				
5	Hexagon flange bolts M6x16	8~12	0.8~1.2	69~103.6 in·lb	
6	Shift decorative cover				
7	M6 nut clamp				
8	Left trim board - short car				
9	Left guard plate - short car				
10	Right guard plate - short car				

11	CVT Anti-ironing plate				
12	Hexagon flange bolts M5×12				
13	Left foot pedal - short car				
14	Cross recessed pan head tapping screws ST4.2x16				
15	Large pan head hexagon bolts M6x16	8~12	0.8~1.2	69~103.6 in·lb	
16	4.2 Self-tapping cleats				
17	Tail box cover pin shaft				
18	Fasten the hands on the storage box				
19	Storage box cover				
20	Storage boxes				

EXPLOSION DIAGRAM OF REAR EXTERIOR TRIM

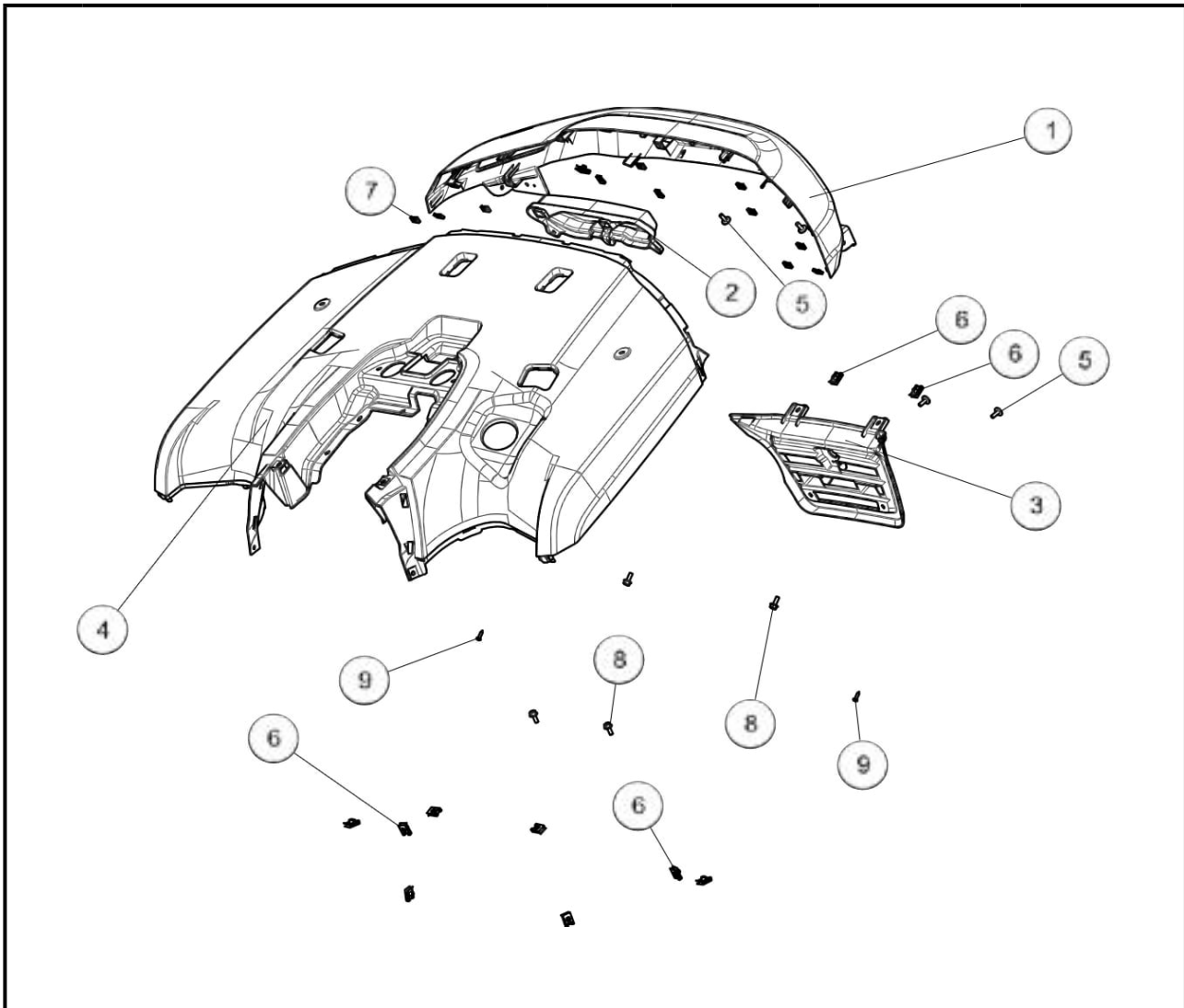

No.	Fastener	Torque			Remarks
		N·m	kgf·m	ft·lb	
1	Rear taillight mask				
2	Lampshade				
3	Rear trim board				
4	Left foot pedal - short car				
5	Large pan head hexagon bolts M6x16	8~12	0.8~1.2	69~103.6 in·lb	
6	M6 nut clamp				
7	4.2 Self-tapping cleats				
8	Hexagon flange bolts M6x16	8~12	0.8~1.2	69~103.6 in·lb	
9	Cross recessed pan head tapping screws ST4.2x16	8~12	0.8~1.2	69~103.6 in·lb	

EXPLOSION DIAGRAM OF UNDERBODY EXTERIOR TRIM

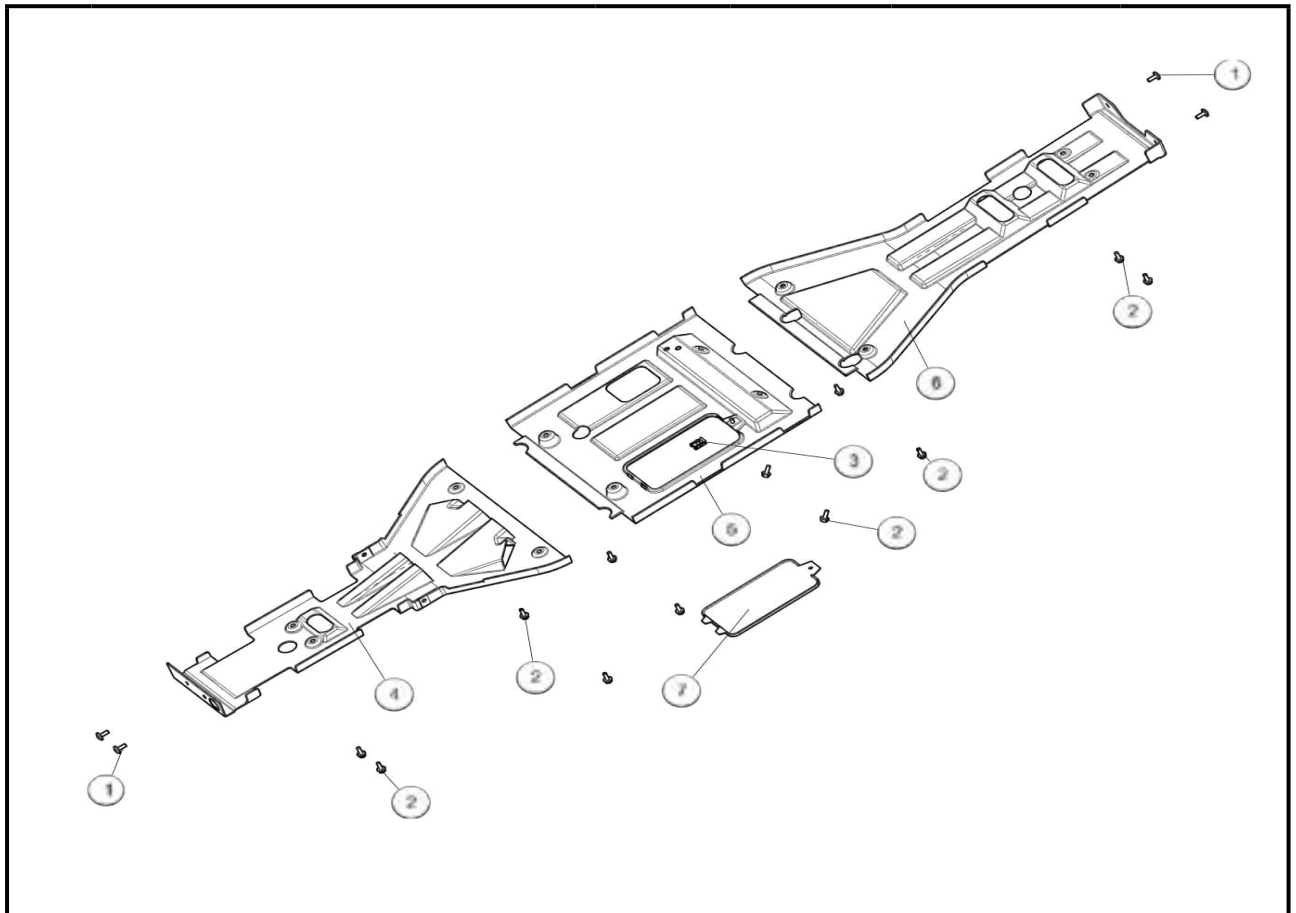

No.	Fastener	Torque			Remarks
		N·m	kgf·m	ft·lb	
1	Large pan head hexagon bolt M6x16	8~12	0.8~1.2	69~103.6 in·lb	
2	Hexagon flange bolts M6x16	8~12	0.8~1.2	69~103.6 in·lb	
3	M6 nut clamp				
4	Frame front bottom plate				
5	frame bottom plate				
6	frame rear bottom plate - short				
7	Frame bottom maintenance cover plate				

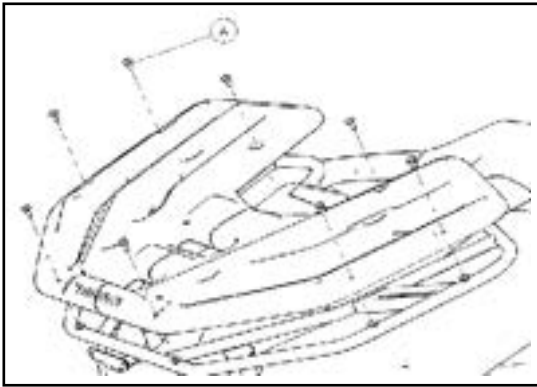

FRONT SHELF COVER

First place the car body in a horizontal position

- ◆ Take out 8 bolts of front shelf cover plate 【A】 .
- ◆ Remove the front shelf cover from the body.

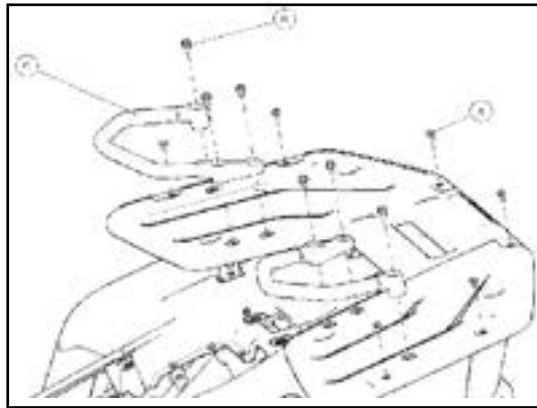

REAR SHELF COVER

First place the car body in a horizontal position

- ◆ Take out the rear left and right handrail fixing bolts 【B】 , remove the rear handrail 【C】 .
- ◆ Take out the 8 bolts of the rear shelf cover 【A】 and remove the rear shelf cover from the body.

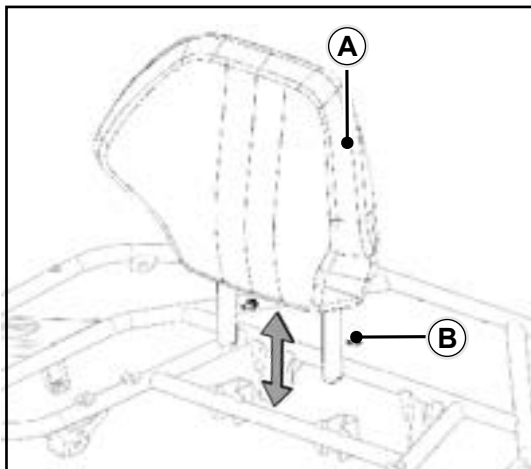

CUSHION REMOVAL

- ◆ Use tools to remove the two locking bolts at the back of the cushion 【B】
- ◆ Pull the cushion 【A】 up directly

MOUNTING CUSHION

- ◆ Align the two positioning sheet metal and insert it into place.
- ◆ Use the tool to lock the bolt 【B】 to tighten it.

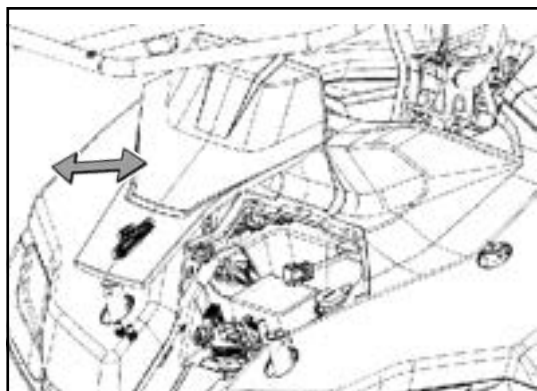

FRONT SERVICE COVER REMOVED

- ◆ Lift up the front of the maintenance cover
- ◆ Pull out service cover in arrow direction

PRE-INSTALLATION SERVICE COVER

- ◆ Align the two fixed jacks to the bottom.
- ◆ Press down on the front of the service cover to insert the mushroom head into the rubber seat.

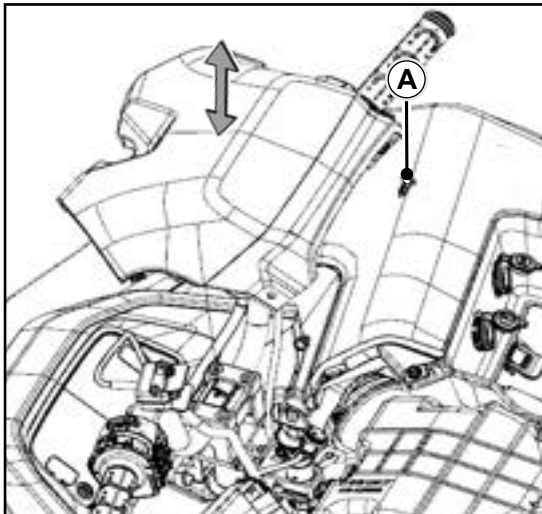

AIR FILTER COVER REMOVED

- ◆ Remove the expansion screws on both sides 【A】
- ◆ Pull out service cover in arrow direction

MOUNTING CUSHION

- ◆ Align the positioning card slot downward into place.
- ◆ Press the expansion screw 【A】 into the corresponding mounting hole.

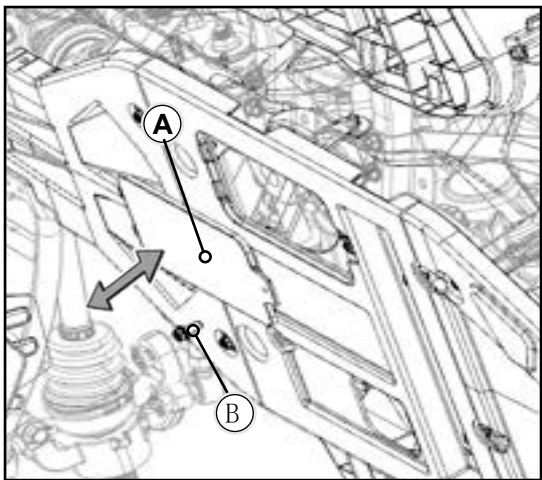

FRAME BOTTOM MAINTENANCE COVER REMOVED

- ◆ Remove maintenance cover plate fixing bolts 【B】
- ◆ Take out the service cover 【A】

MOUNTING CUSHION

- ◆ Align the positioning pin of the service cover plate with the two positioning jacks.
- ◆ Close the service cover 【A】 and install the fixing bolt 【B】 in place.

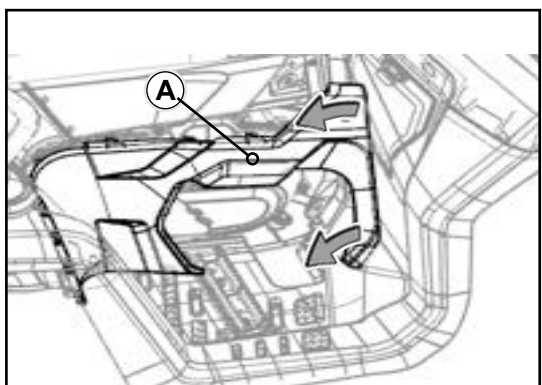

REMOVE THE RIGHT GUARD PLATE

- ◆ Pull the front end of the protection plate outward in the direction of the arrow, so that the mushroom head is removed from the fixed rubber sleeve
- ◆ Push the right guard to the front 【A】

MOUNTING CUSHION

- ◆ Push the right guard plate 【A】 into the fixing slot from the front direction to the rear direction.
- ◆ Insert the upper and lower mushroom heads of the front end of the right guard plate 【A】 into the fixed rubber sleeve

ENGINE DISASSEMBLY EXPLOSION DIAGRAM

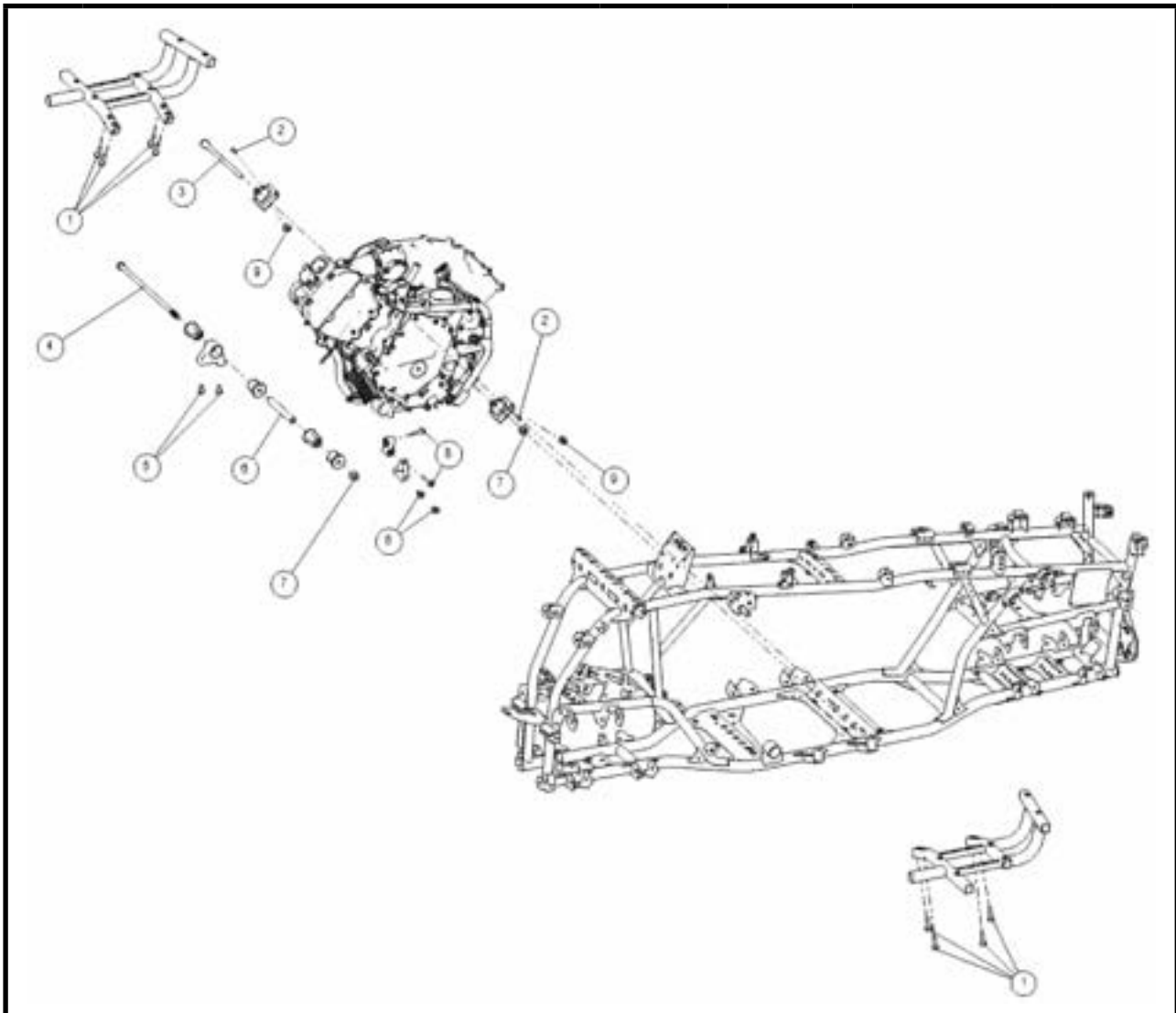

No.	Fastener	Torque			Remarks
		N·m	kgf·m	ft·lb	
1	1 Hexagon flange bolt M8×30	30□40	3.0~4.0	22.1~29.5	
2	Hexagon flange bolts M6x12	8~12	0.8~1.2	69~103.6 in·lb	
3	Hexagon flange shaft bolt M12×1.25×210	50□60	5.0~6.0	36.9~44.3	
4	Engine mounting shaft 1	50□60	5.0~6.0	36.9~44.3	
5	Hexagon flange bolts M8×16	30□40	3.0~4.0	22.1~29.5	
6	Liner				
7	Engine mounting nut M12 x 1.25	50□60	5.0~6.0	36.9~44.3	
8	Hexagon flange bolts M8×35	30□40	3.0~4.0	22.1~29.5	
9	Engine buffer block mounting nut M10 x 1.25	40□50	4.0~5.0	29.5~36.9	

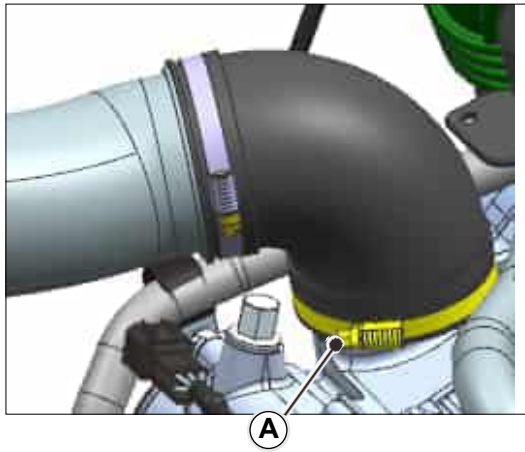

DISASSEMBLY

- ◆ Remove the bottom plate. (See car body section for details)
- ◆ Remove the outer central plastic parts. (See car body section for details)
- ◆ Pull out the connectors or cables on the engine, disconnect the connection with the main cable.
- ◆ Remove the installation bolts of CVT inlet duct 2 with appropriate tools 【A】 .
- ◆ Remove the hoop 【B】 with a flat-mouth screwdriver, and remove the CVT inlet duct 1.

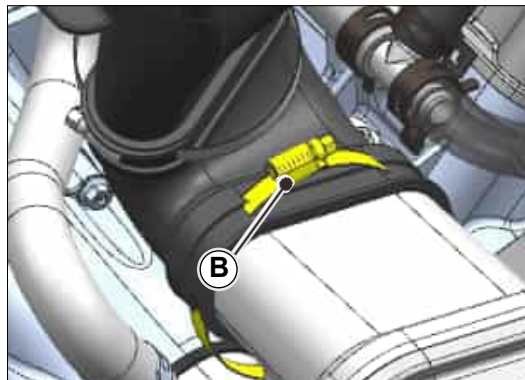

⚠ CAUTION

After removing the CVT air inlet pipe, protect the CVT air inlet effectively to prevent debris from falling into the engine and damaging the engine.

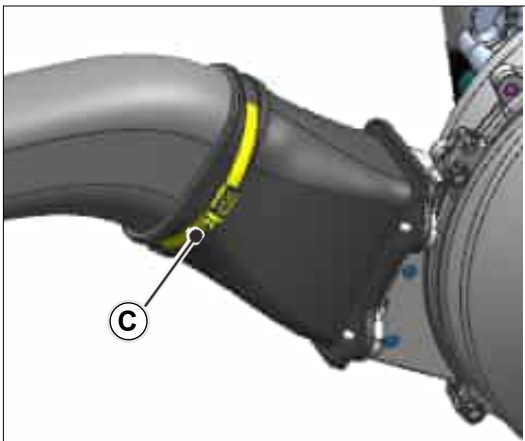

⚠ CAUTION

After removing the CVT air outlet, protect the CVT air outlet effectively to prevent debris from falling into the engine and damaging the engine.

- ◆ Remove the hoop with a screwdriver 【C】 and remove the CVT outlet pipe.

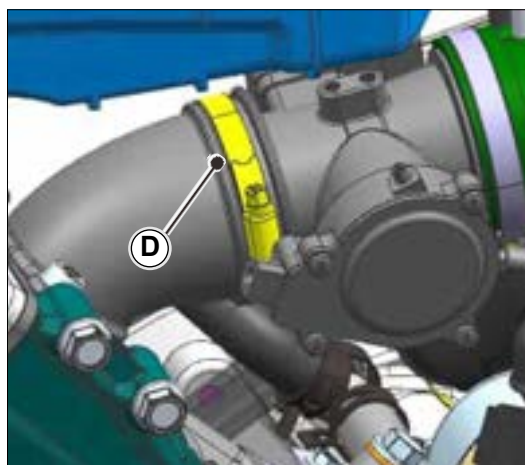

⚠ CAUTION

After removing the throttle valve, please effectively protect the engine inlet to avoid debris from falling into the engine, thus damaging the engine.

After removing the throttle valve, please effectively protect the throttle valve to avoid damaging the throttle valve.

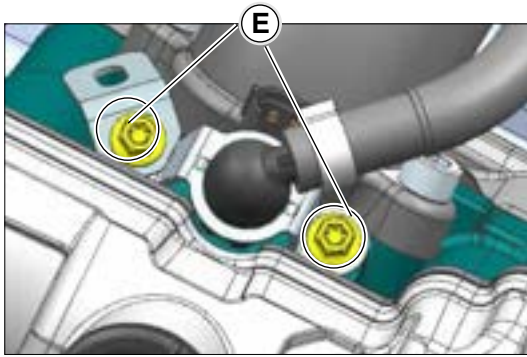

- ◆ Remove the injector mounting bolt with the appropriate tool 【E】 , remove the injector.

⚠ CAUTION

After removing the injector, please effectively protect the injector to prevent debris from blocking the injection hole of the injector, thus damaging the injector.

After removing the injector, please effectively protect the engine injector mounting hole to prevent debris from falling into the engine from the injector mounting hole, thus damaging the engine.

Fuel injector mounting bolt torque
10N · m

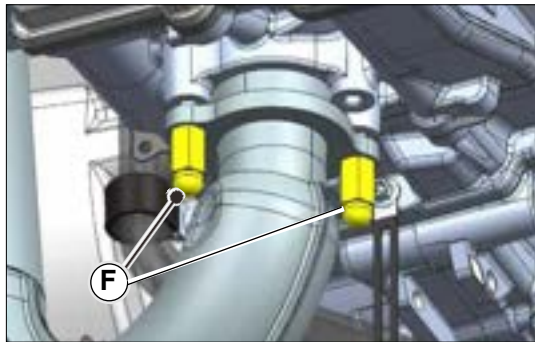

- ◆ Remove the exhaust muffler mounting nut 【F】 with appropriate tools and remove the exhaust muffler.

Exhaust muffler mounting nut torque
35N · m~45N · m

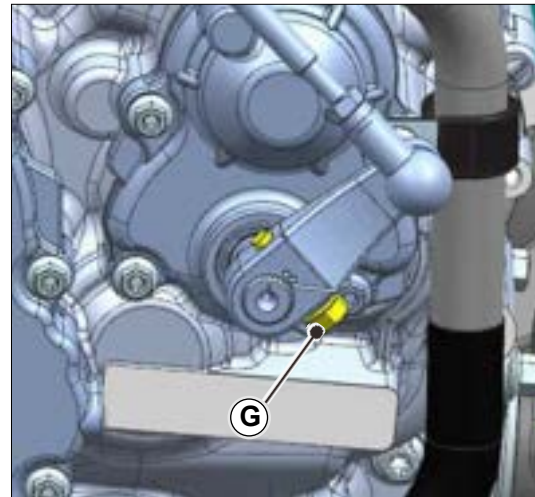

- ◆ Remove the mounting bolts of the shifting rocker arm with appropriate tools 【G】 and remove the shifting rocker arm. .

Shift rocker arm mounting bolt torque
8N · m~12N · m

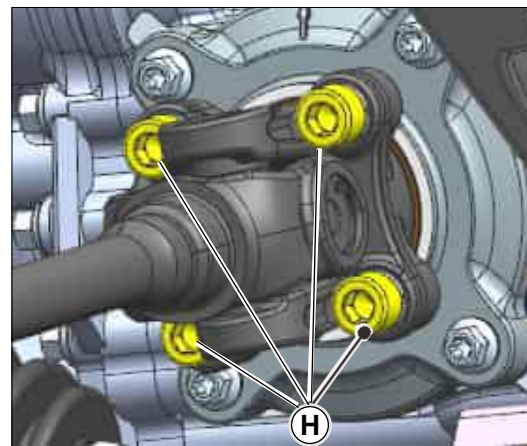

- ◆ Remove the 4 mounting screws of the front drive shaft and engine with appropriate tools 【H】 , so that the front drive shaft is disconnected from the engine. .

Front drive shaft mounting screw torque
45N · m

Apply appropriate amount of thread glue to the front drive shaft mounting screws during assembly

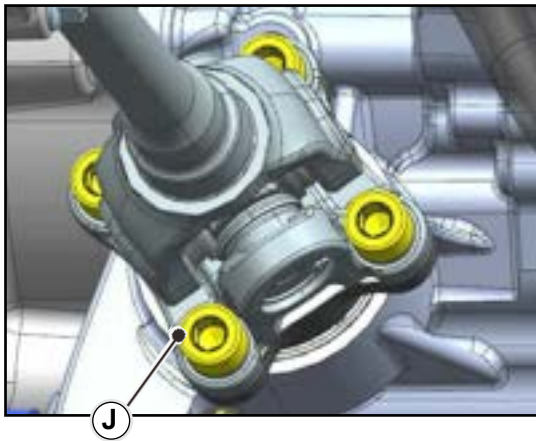

- ◆ Remove the 4 mounting screws of the rear drive shaft and engine with appropriate tools 【J】 , disconnect the front drive shaft from the engine. .

⚠ CAUTION

After removing the front and rear drive shafts, apply thread glue to the mounting screws during assembly and fastening to prevent screws from loosening and falling off.



- ◆ Remove the clamp with the water pipe clamp clamp 【K】 Remove the radiator outlet pipe and discharge the coolant.

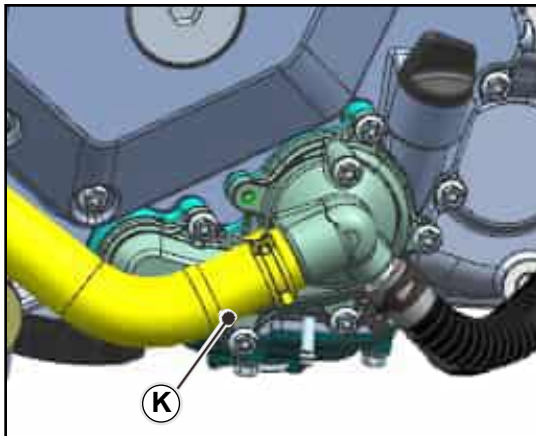

- ◆ Remove the clamp with the water pipe clamp clamp 【L】 Remove the radiator inlet pipe and discharge the coolant.

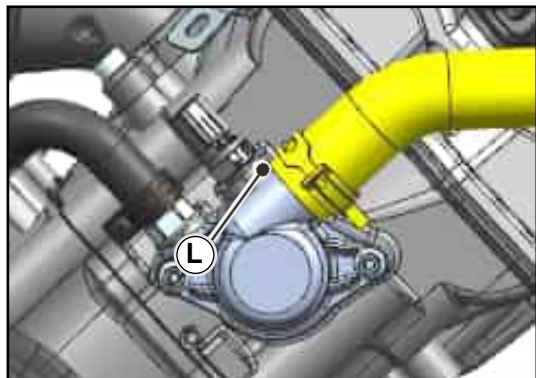

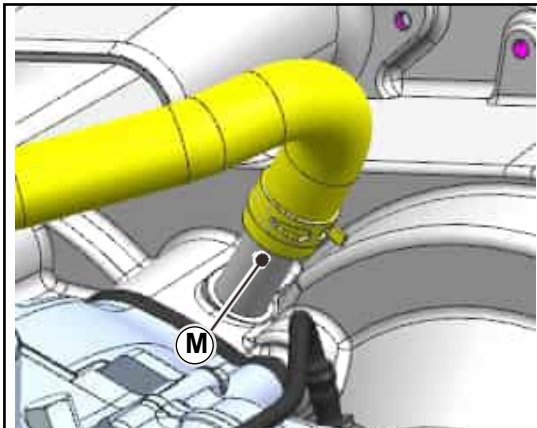

- ◆ Remove the clamp with the water pipe clamp clamp
【M】 Remove the engine exhaust pipe.

CAUTION

After removing the exhaust pipe and radiator inlet and outlet pipes, protect the corresponding interfaces on the engine to prevent debris from falling into the engine and damaging the engine.

- ◆ Remove the bolt parts with appropriate tools 6, remove the parking adapter bracket assembly.
- ◆ Remove bolt parts 19 and 17 with appropriate tools, and remove the left foot guard bar combination.
- ◆ Remove bolt parts 15 and 18 with appropriate tools, and remove the left foot support assembly.
- ◆ Remove bolt parts 1 and 2 with appropriate tools, and remove the right foot guard bar combination.
- ◆ Remove the bolt with the appropriate tool 13, remove the right foot support assembly.
- ◆ Remove bolt parts 4 with appropriate tools, so that the engine hanging assembly is disconnected from the engine.
- ◆ Remove the bolt parts with appropriate tools 5, remove the suspension buffer rubber sleeve and the engine hanger assembly.
- ◆ Remove screw parts 9 and 12 with appropriate tools.
- ◆ Remove nut parts 8 and 7 with appropriate tools, pull out nut parts 13 and 16.

⚠ CAUTION

When installing shaft bolts and engine mounting shaft 1 before pulling out the engine, ensure that all parts connected to the engine are disconnected to avoid damage to other parts.

- ◆ Remove bolt parts 14 with appropriate tools and remove the mounting seat.
- ◆ Remove nut parts 10 and 11 with appropriate tools and remove engine buffer blocks.
- ◆ Use appropriate tooling to lift the engine assembly from the left side of the vehicle, and please handle gently.

FRONT AND REAR AXLE DISASSEMBLY EXPLOSION DIAGRAM

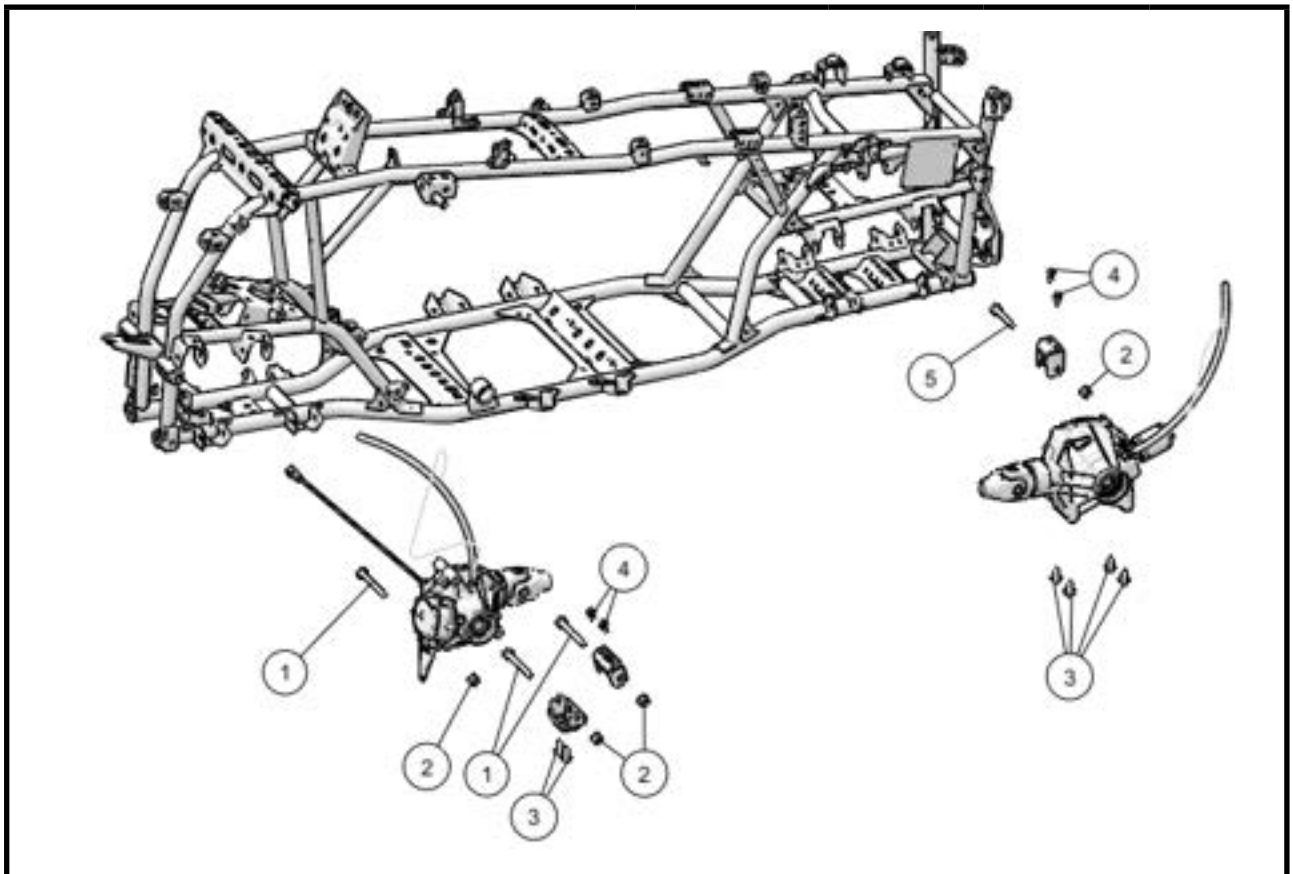

No.	Fastener	Torque			Remarks
		N·m	kgf·m	ft·lb	
1	Hexagon flange bolt M10×1.25×105	40□50	4.0~5.0	29.5~36.9	
2	Hexagon flange locking nut M10 x 1.25	40□50	4.0~5.0	29.5~36.9	
3	Hexagon flange bolts M10 x 1.25 x 20	40~50	4.0~5.0	29.5~36.9	
4	Hexagon flange bolts M8×16	22~30	2.2~3.0	17~22	

FRONT AXLE MAINTENANCE

DISASSEMBLY

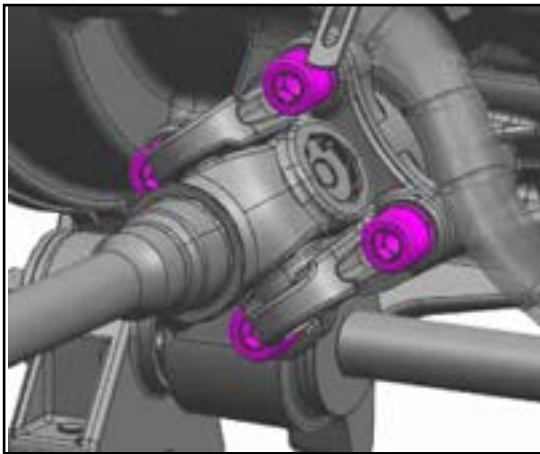
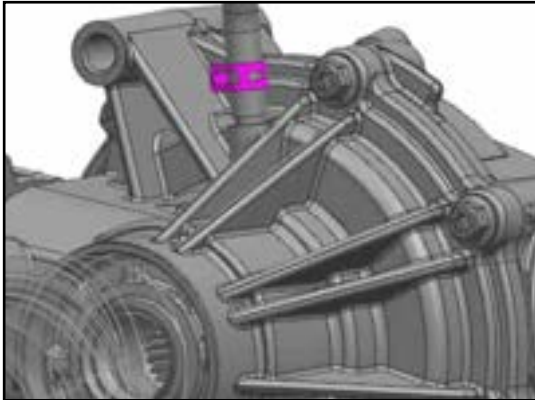

- ◆ Remove front lower right rocker arm welding assembly and front upper right rocker arm welding assembly. (See Suspension section for details)
- ◆ Remove front lower left rocker arm welding assembly and front upper left rocker arm welding assembly. (See Suspension section for details)
- ◆ Remove the connection between the front constant speed drive shaft and the front axle assembly.
- ◆ Pull out or remove the connectors or cables on the front axle assembly and disconnect the connection with the main cable.
- ◆ Remove the hoop with appropriate tools, and remove the front bridge vent pipe.
- ◆ Remove 4 bolts with appropriate tools, and disconnect the front drive shaft assembly from the front axle assembly.
- ◆ Remove nut part 2, bolt part 1, and bolt part 1 with appropriate tools, and remove the front underbridge mounting bracket group. Remove nut 4 and the mounting bracket assembly from the front axle.
- ◆ Remove bolt parts 3 with appropriate tools, and remove the front axle assembly from right to left. .

Front drive shaft mounting screw torque

40N · m~50N · m

⚠ CAUTION

Before removing the front axle assembly, ensure that the wiring harness on the front axle assembly is completely disconnected from the frame or main cable.

ASSEMBLY

- ◆ When assembling, please reverse assemble according to disassembly sequence.
- ◆ Apply appropriate amount of thread glue to the front drive shaft mounting screws during assembly.

REAR AXLE MAINTENANCE

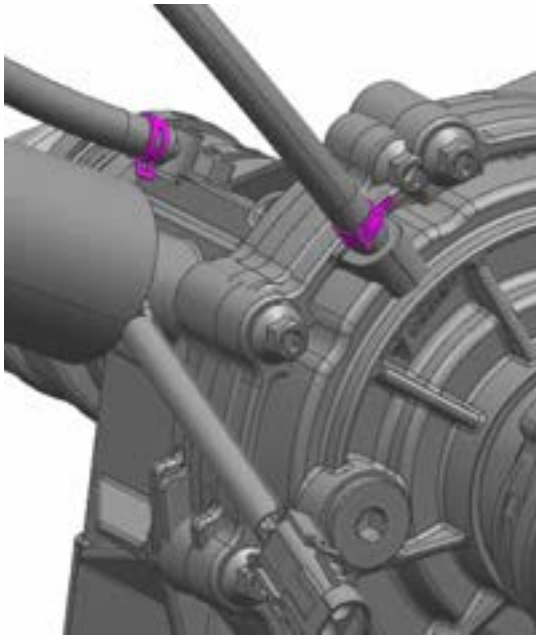

DISASSEMBLY

- ◆ Pull out or remove the connectors on the rear axle assembly and disconnect the connection with the main cable.
- ◆ Remove the connection between brake assembly and rear axle assembly.
- ◆ Connection between left and right constant speed drive shaft and rear axle assembly after removal.
- ◆ Remove the hoop with appropriate tools, and remove the rear axle vent pipe.
- ◆ Remove 4 bolts with appropriate tools, and disconnect the rear drive shaft assembly from the rear axle assembly.
- ◆ Remove bolt parts with appropriate tools 2,5,4 Remove the rear axle mounting bracket assembly.
- ◆ Remove bolt parts 3 with appropriate tools.
- ◆ Take out the rear axle assembly from right to left.

⚠ CAUTION

Before removing the rear axle assembly, ensure that the wiring harness on the front axle assembly is completely disconnected from the frame or main cable.

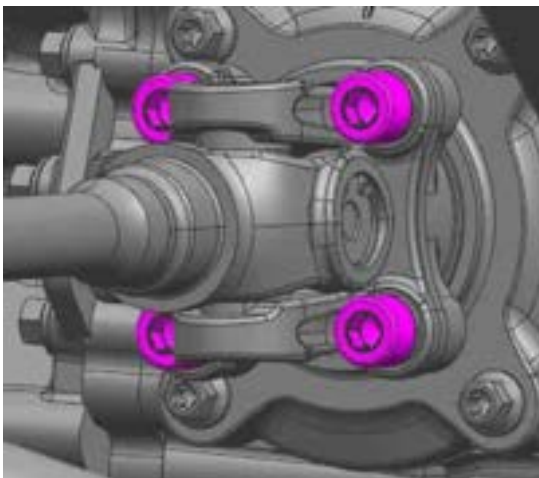

ASSEMBLY

- ◆ When assembling, please reverse assemble according to disassembly sequence.

FRONT AND REAR SHELF DISASSEMBLY EXPLOSION DIAGRAM

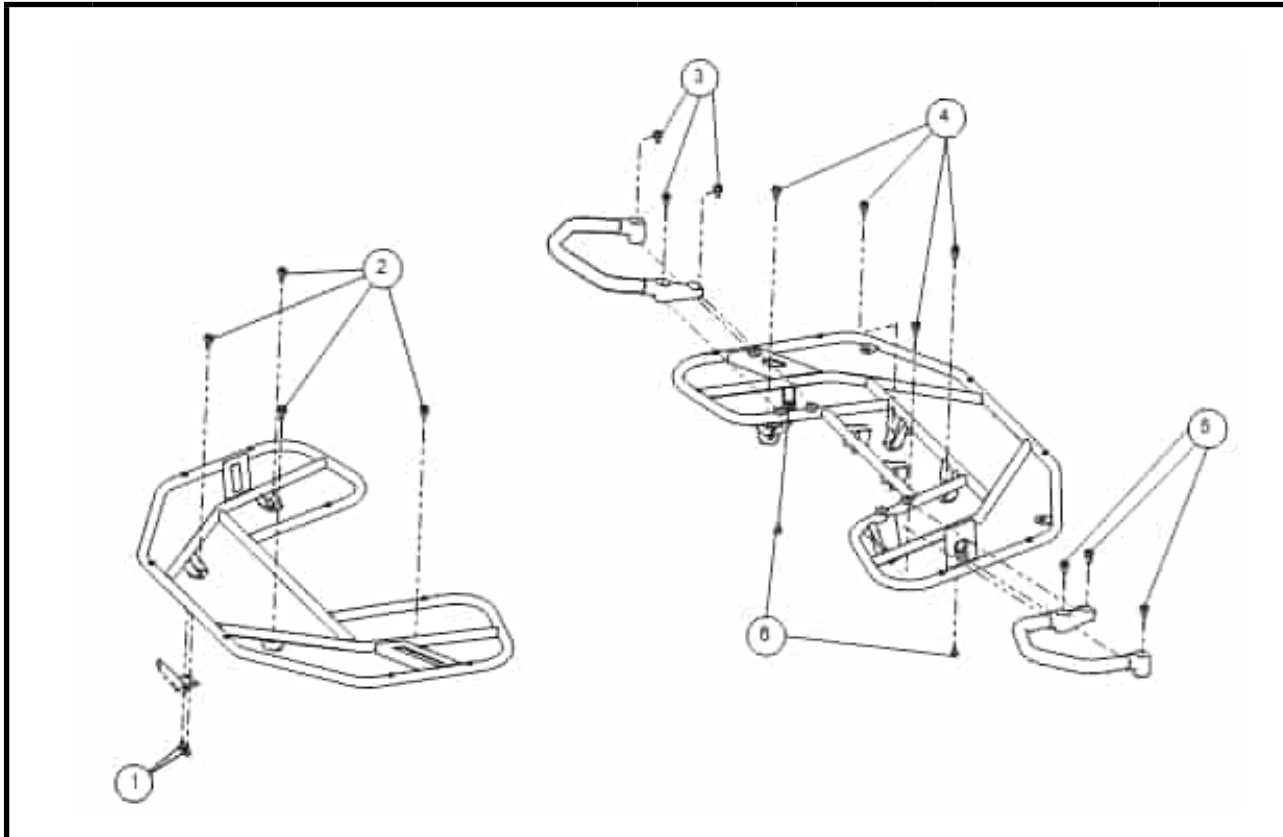

No.	Fastener	Torque			Remarks
		N·m	kgf·m	ft·lb	
1	Front plate mounting bolts M6x12	8~12	0.8~1.2	69~103.6 in·lb	
2	bolts M8x16	30~40	3.0~4.0	22.1~29.5	
3	bolts M8x16	30~40	3.0~4.0	22.1~29.5	
4	bolts M8x16	30~40	3.0~4.0	22.1~29.5	
5	M8x16 bolts for the left handrail assembly	30~40	3.0~4.0	22.1~29.5	
6	M8x16 bolts for the left handrail assembly	8~12	0.8~1.2	69~103.6 in·lb	

FRAME ACCESSORY EXPLOSION DIAGRAM

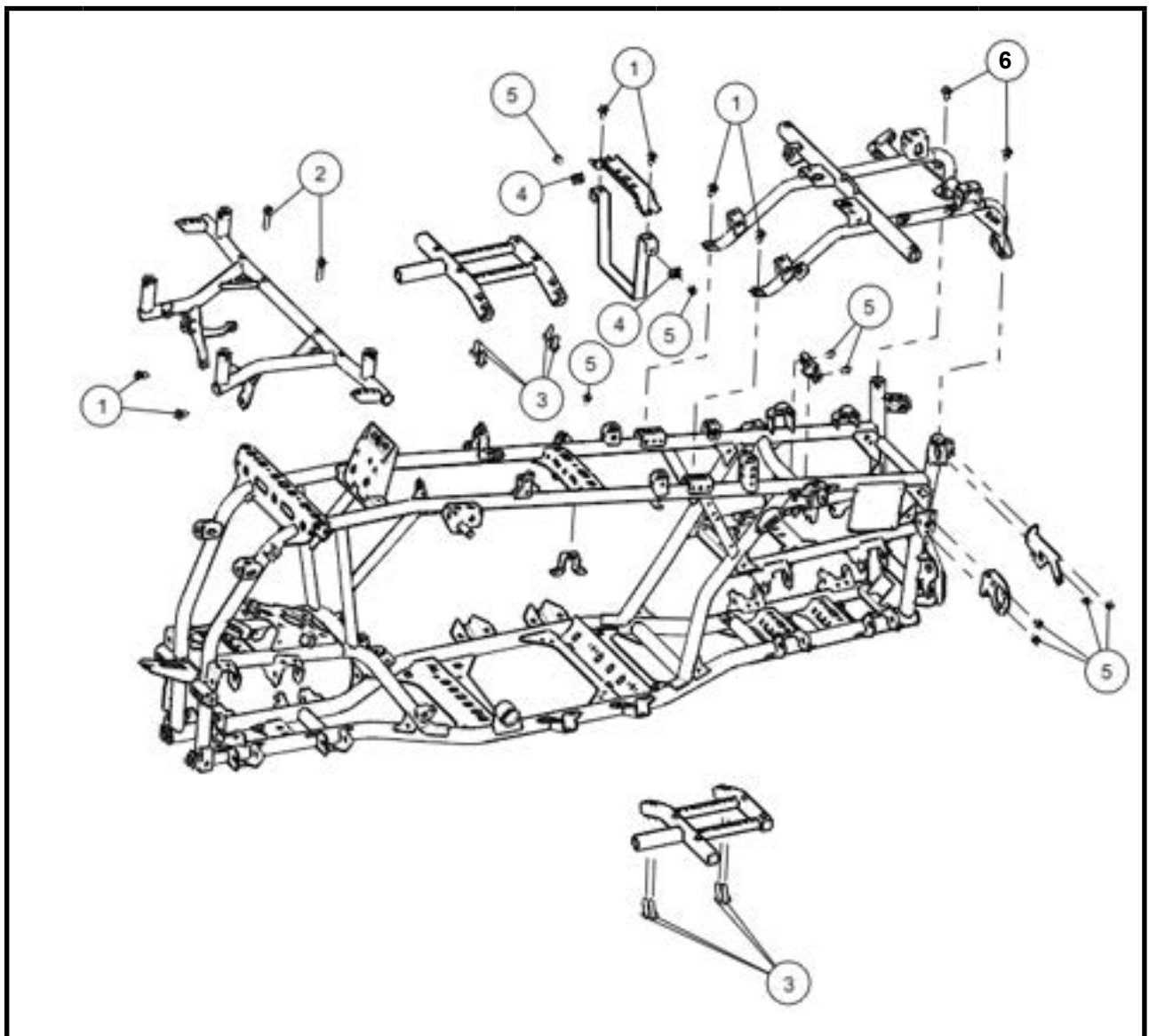

No.	Fastener	Torque			Remarks
		N·m	kgf·m	ft·lb	
1	Frame accessory explosion diagram	30~40	3.0~4.0	22.1~29.5	
2	Hexagon flange bolts M8×40	30~40	3.0~4.0	22.1~29.5	
3	Hexagon flange bolts M8×25	30~40	3.0~4.0	22.1~29.5	
4	M6 nut clamp				
5	Hexagon flange bolts M6×12	8~12	0.8~1.2	69~103.6 in·lb	
6	Hexagon flange boltsM10×40	40~50	4.0~5.0	29.5~36.9	

FRAME ACCESSORY REMOVED

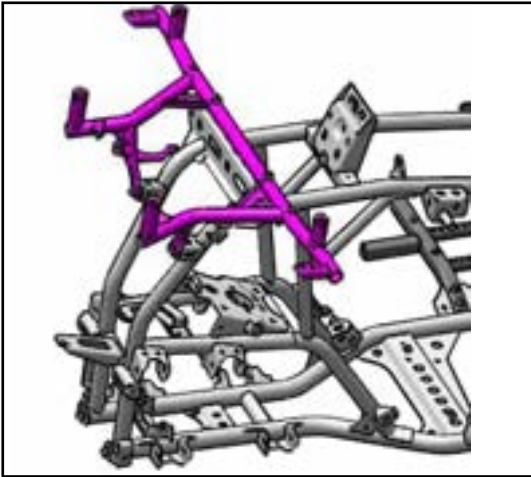

- ◆ Remove the bolt on the upper support of the rear storage box (hexagonal flange bolt 2-M8×16, 2-2-M8×40) and remove the front shelf support assembly.

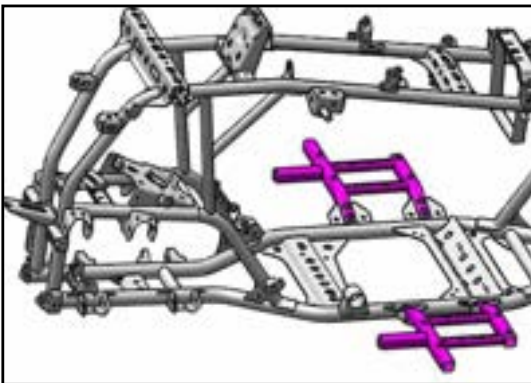

- ◆ Remove the bolt (hex flange bolt 4-M8×30) and remove the left and right foot pedal welding assembly. You may need to remove plastic parts such as the left and right foot pedals before doing so (refer to the relevant section for details)

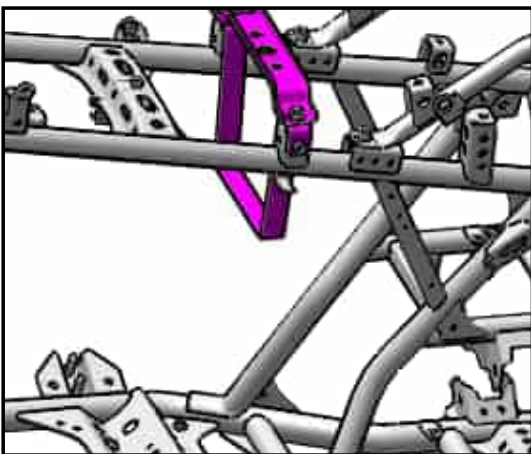

- ◆ Remove the upper mounting bolts of the battery plate (hexagonal flange bolts 2-M8×16), remove the battery and the plastic parts of the battery box. Before this, you need to remove the seat cushion assembly and cable (refer to the relevant section for details)

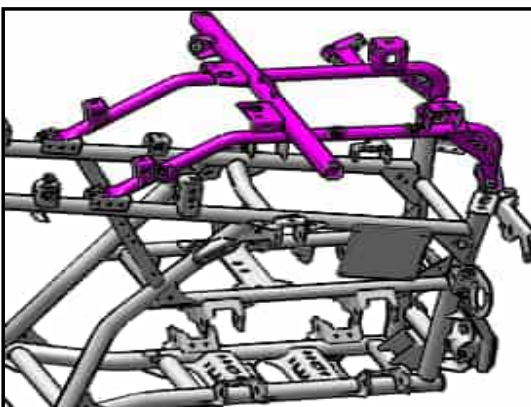

- ◆ Remove the front and rear mounting bolts (hexagonal flange bolts 4-M8×16) of the rear shelf support assembly. Before this, you need to remove the left and right handrails, cargo cover plates, rear fenders and other plastic parts, as well as the muffler cylinder.

FRONT BUMPER EXPLOSION DIAGRAM

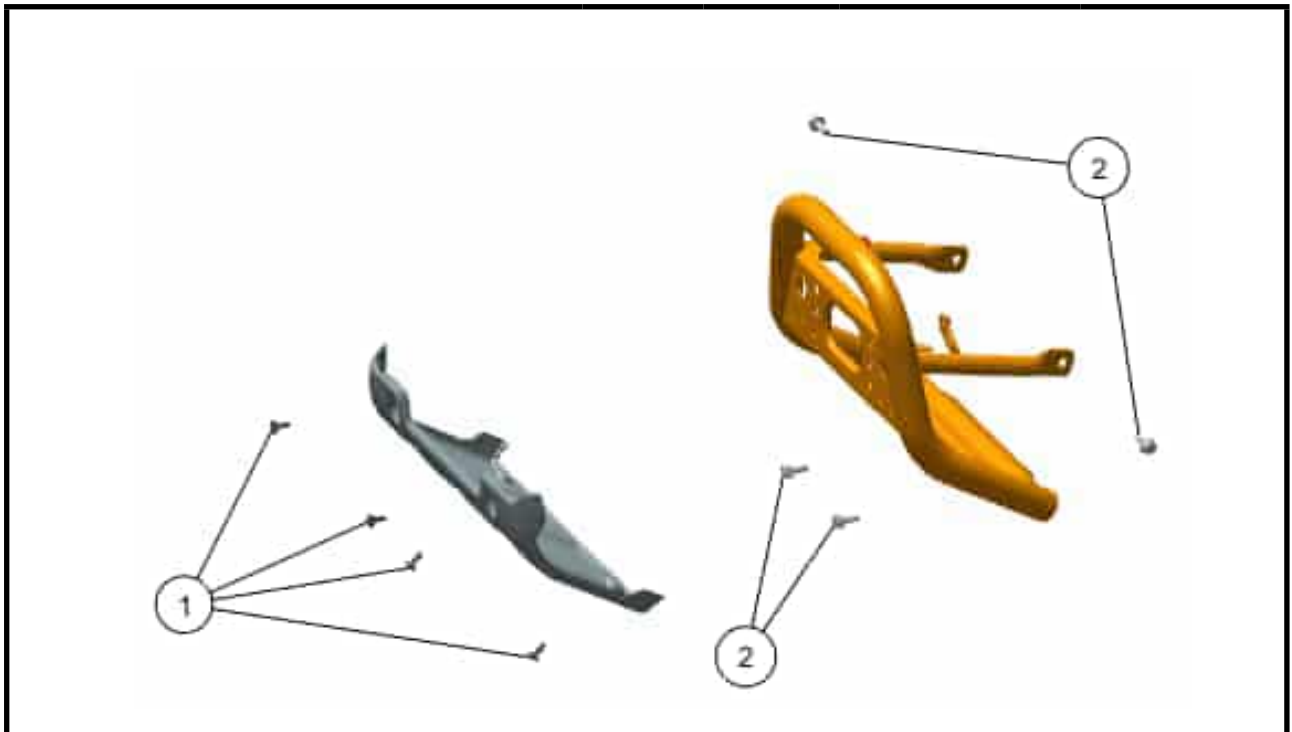

No.	Fastener	Torque			Remarks
		N·m	kgf·m	ft·lb	
1	Large pan head hexagon bolt M6x16	40~50	4.0~5.0	30~37	
2	Hexagon flange bolts M8x20	22~30	2.2~3.0	17~22	

FRONT BUMPER REMOVAL

- ◆ Remove the lock nut of the winch motor line and remove the winch motor line.

CAUTION

After removing the winch motor line, the head of the cable should be protected to prevent short circuit.

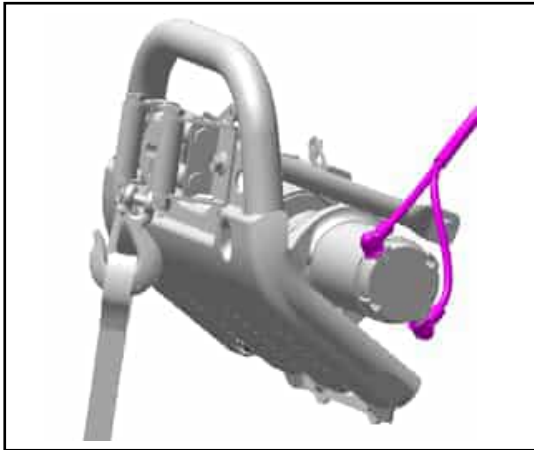

- ◆ Remove the front bumper assembly mounting bolt (hex flange bolt 4-M8×20) and remove the bumper assembly.

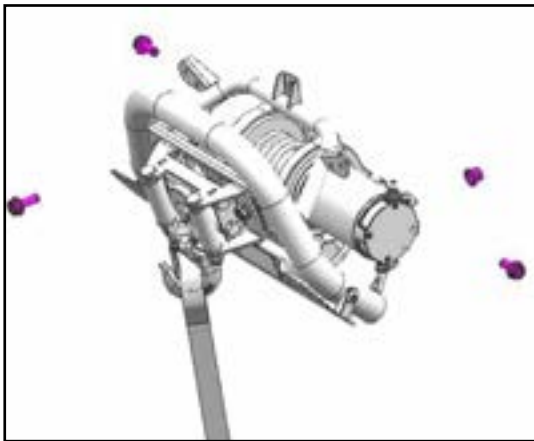

- ◆ Remove the mounting bolts of the front bumper trim panel assembly (large pan head hexagon bolt 4-M6×16) and remove the front safety trim panel assembly.

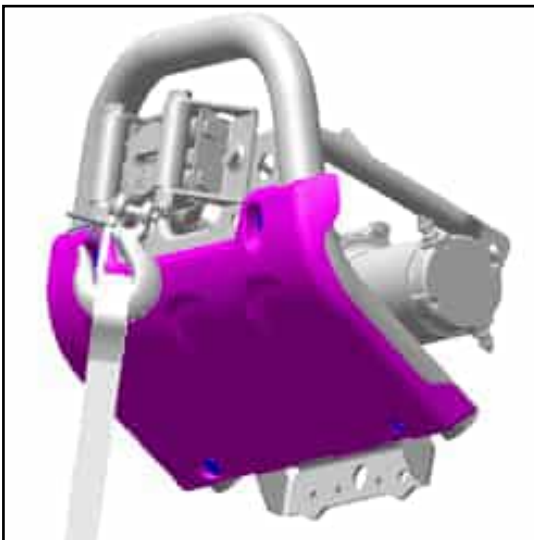

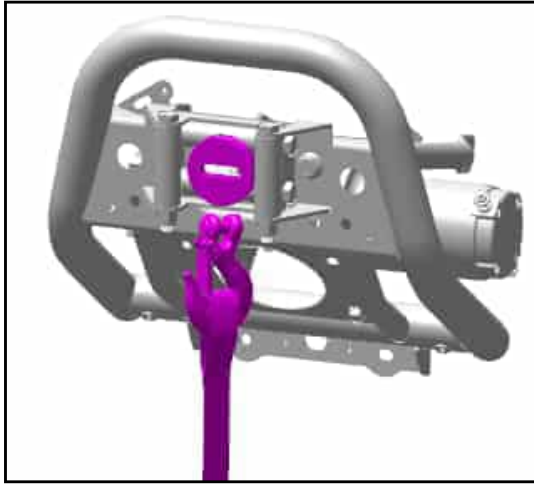

- ◆ Unplug the pin of the winch hook, remove the winch hook and the winch rubber pad.

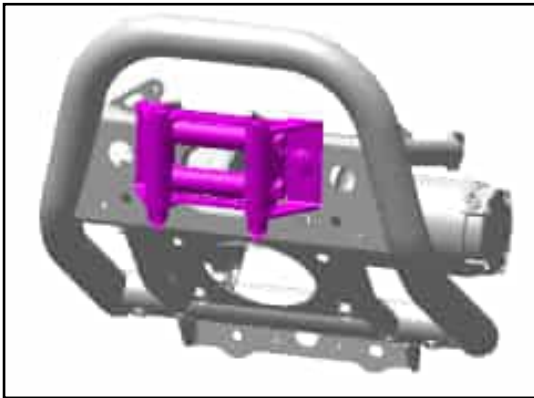

- ◆ Remove the mounting bolt of the winch motor (hexagon flange bolt M8×20) and remove the winch motor.

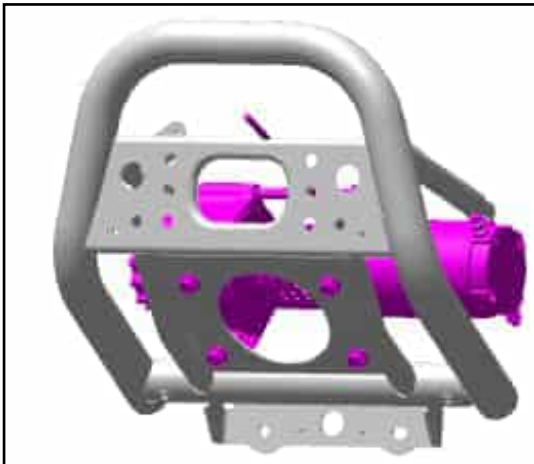

- ◆ Remove the mounting bolt of the winch motor (hexagon flange bolt M8×20) and remove the winch motor.

- ◆ To install the front bumper, follow the reverse procedure

ELECTRICAL SYSTEM

EXPLODED VIEW	14-3
TECHNICAL PARAMETERS	14-6
SPECIAL TOOLS	14-7
BATTERY	14-8
REMOVE THE BATTERY	14-8
TURN OFF IGNITION SWITCH	14-8
BATTERY CHARGING	14-9
CHARGING CONDITION CHECK	14-11
GENERATOR INSPECTION	14-12
CIRCUIT DIAGRAM OF CHARGING SYSTEM.....	14-13
VOLTAGE REGULATING RECTIFIER INSPECTION.....	14-14
REMOVE.....	14-14
EFI SYSTEM	14-15
SCHEMATIC DIAGRAM OF EFI SYSTEM	14-15
TEMPERATURE SENSOR	14-16
FUNCTION INTRODUCTION	14-16
WORKING PRINCIPLE.....	14-16
PERFORMANCE PARAMETER	14-17
OXYGEN SENSOR	14-18
FUNCTION INTRODUCTION	14-18
WORKING PRINCIPLE.....	14-18
PERFORMANCE PARAMETER	14-19
ELECTRICAL CHARACTERISTIC PARAMETER.....	14-19
CARBON CANISTER SOLENOID VALVE	14-21
FUNCTION DESCRIPTION	14-21
FUNCTION INTRODUCTION	14-22
ELECTRICAL CHARACTERISTICS	14-22
FAULT DIAGNOSIS.....	14-22
ECU STITCH DEFINITION	14-23
ELECTRONIC THROTTLE BODY DVE SELF-LEARNING PROCESS.....	14-24
FUEL INJECTOR	14-24
PERFORMANCE PARAMETERS	14-25
FAULT DIAGNOSIS.....	14-25
IGNITION COILS	14-26
WORKING PRINCIPLE.....	14-26
PERFORMANCE PARAMETERS.....	14-27
FAULT DIAGNOSIS.....	14-27
REMOVE AND INSTALL SPARK PLUGS	14-28
ENGINE SPEED SENSOR	14-29
TECHNICAL PERFORMANCE TEST	14-29
FAULT DIAGNOSIS.....	14-29
OIL PRESSURE SENSOR	14-30
FAULT DIAGNOSIS.....	14-30
THROTTLE VALVE BODY ASSEMBLY	14-31
THREE-IN-ONE SENSOR	14-31
THREE-IN-ONE SENSOR PERFORMANCE CHARACTERISTICS	14-32

IDLE MOTOR	14-33
IDLE MOTOR FLOW CHARACTERISTICS.....	14-34
FAULT DIAGNOSIS.....	14-34
IDLE MOTOR FAULT CHECK:.....	14-34
FAULT CODE READING.....	14-35
TROUBLESHOOTER OPERATION.....	14-35
SUMMARY OF FAILURE CODES (ECU)	14-36
LIGHTING SYSTEM CIRCUIT	14-38
HEADLAMPS	14-39
REPLACE.....	14-39
TAIL LAMP	14-40
TAIL LAMP 1	14-40
TAIL LAMP 2	14-40
LICENSE PLATE LAMP	14-41
REMOVE.....	14-41
REPLACEMENT ASSEMBLY.....	14-41
FLASHER	14-42
DISASSEMBLY	14-42
EPS-BRUSHLESS	14-43
EPS SYSTEM WIRING SCHEMATIC DIAGRAM	14-44
EPS TROUBLE REMOVAL.....	14-45
DISPLAY AND HUMAN-COMPUTER INTERACTION	14-47
DASHBOARD.....	14-47
DASHBOARD INDICATOR LIGHT DESCRIPTION	14-48
INSTRUMENT INFORMATION DISPLAY	14-50
DASHBOARD DISASSEMBLY AND ASSEMBLY	14-53
T-BOX	14-55
T-BOX FAULT CODE DISPLAY AREA.....	14-55
T-BOX INTERFACE DEFINITION	14-56
SWITCH	14-57
POWER LOCK	14-57
LEFT HANDLEBAR SWITCH	14-58
ASSEMBLY AND DISASSEMBLY OF LEFT HANDLEBAR SWITCH	14-60
SPEED SWITCH	14-60
RIGHT HANDLEBAR SWITCH	14-61
ASSEMBLY AND DISASSEMBLY OF RIGHT HANDLEBAR SWITCH.....	14-61
WINCH ASSEMBLY	14-62
REMOVAL	14-62
FUSE BOX	14-65
FUEL BOX LABEL.....	14-66
WIRE HARNESS	14-67
WIRE HARNESS ASSEMBLY.....	14-68
WIRING DIAGRAM	14-69
ABS SYSTEM (APPLICABLE TO ABS MODELS)	14-70
FUNCTION DESCRIPTION.....	14-70
ABS SYSTEM PARTS.....	14-70
ABS SENSOR.....	14-71
ELECTRONIC CONTROL UNIT.....	14-71
ABS SYSTEM WORKING PRINCIPLE DIAGRAM.....	14-72
ABS FAULT DIAGNOSIS CODE.....	14-73

EXPLODED VIEW

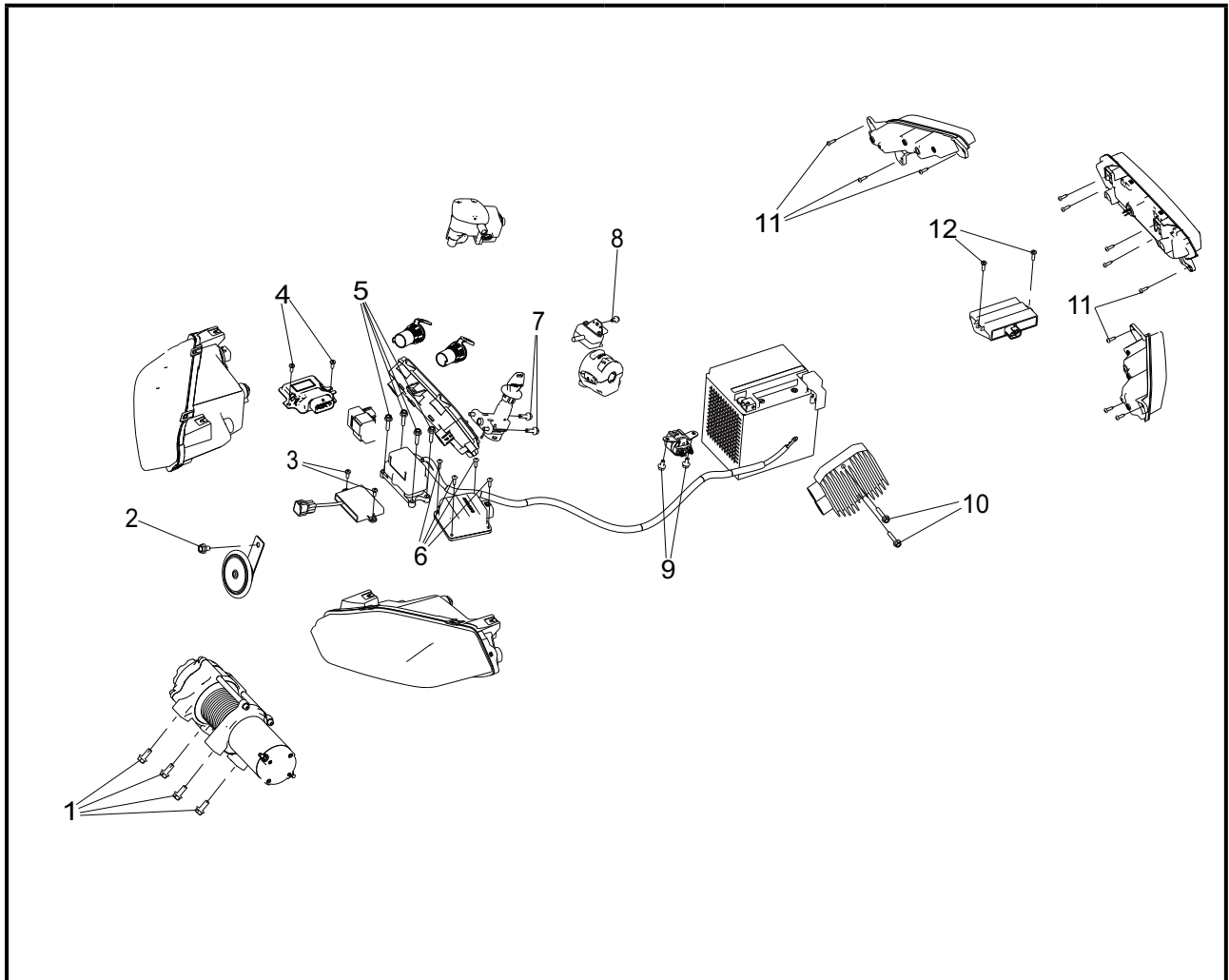

No.	Fastener	Torque			Remarks
		N·m	kgf·m	ft·lb	
1	Hexagonal flange bolt M8×1.25×20	22~28	2.2~2.8	16.2~20.7	
2	Hexagonal flange bolt M8×1.5×1	8~10	0.8~1.0	70.8~88.4in·lb	
3	Cross recessed pan head screw M5×12	3~4	0.3~0.4	26.5~35.4in·lb	
4	Hexalobular pan head screw M6×12	3~5	0.3~0.5	26.5~44.2in·lb	
5	Hexalobular pan head screw M6×12	3~5	0.3~0.5	26.5~44.2in·lb	
6	Cross recessed round head self-tapping screw ST4.2×19	4~5	0.4~0.5	35.4~44.2in·lb	

EXPLODED VIEW

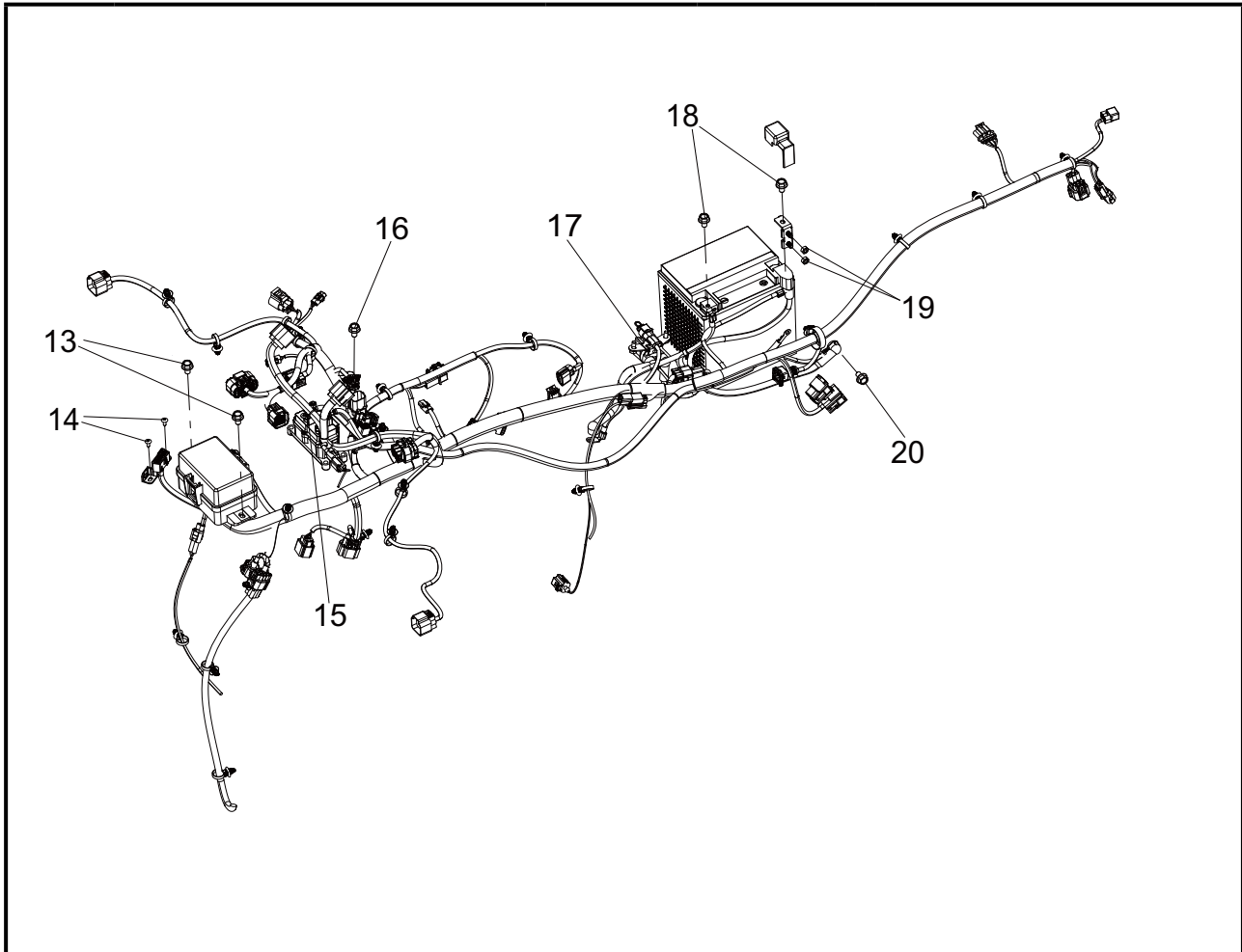

No.	Fastener	Torque			Remarks
		N·m	kgf·m	ft·lb	
7	Hexagonal flange bolt M6×1.25×20	7~9	0.7~0.9	61.9~79.6in·lb	
8	Cross recessed pan head M5×12	3~4	0.3~0.4	26.5~35.4in·lb	
9	Hexagonal flange bolt M6×1.25×12	4~5	0.4~0.5	35.4~44.2in·lb	
10	Hexagonal flange bolt M6×30	10~12	1.0~1.2	7.4~8.8	
11	Cross recessed round head self-tapping screw ST4.2×16	4~5	0.4~0.5	35.4~44.2in·lb	
12	Cross recessed pan head M5×12	3~4	0.3~0.4	26.5~35.4in·lb	
13	Hexagonal flange bolt M6×1.5×12	5~7	0.5~0.7	44.2~61.9in·lb	
14	Cross recessed round head self-tapping screw ST4.2×19	4~5	0.4~0.5	35.4~44.2in·lb	
15	Hexagonal flange bolt M6×1.25×20	7~9	0.7~0.9	61.9~79.6in·lb	
16	Hexagonal flange bolt M6×1.25×12	5~7	0.5~0.7	44.2~61.9in·lb	

ELECTRICAL SYSTEM

SEGWAY AT5

No.	Fastener	Torque			Remarks
		N·m	kgf·m	ft·lb	
17	Hexagonal flange bolt M6×1.25×12	5~7	0.8~1.0	70.8~88.4in·lb	
17	Hexagonal flange bolt M6×1.25×12	5~7	0.8~1.0	70.8~88.4in·lb	
19	M6 nut	7~9	0.7~0.9	61.9~79.6in·lb	
20	Hexagonal flange bolt M6×1.25×12	7~9	0.5~0.7	44.2~61.9in·lb	

TECHNICAL PARAMETERS

Project	Standard	Use limit
Battery: Type Capacity	Sealed Battery 12 V 32 Ah	---
Charging System: Alternator type Charging voltage (Regulator/rectifier output voltage) Alternator output voltage Stator coil resistance	Three-phase DC 14 ~ 15 V AC 36 ~ 54 V 3 000 r/min (rpm) 0.33 ~ 0.49	---
Ignition System: Spark plug: Spark plug gap Spark plug cap resistance Ignition coil: Primary winding resistance Secondary winding resistance	0.7~0.9 mm 3~12kΩ 466~593mΩ 8.2~10.5kΩ	---
Electric Starter System: Starter motor: Commutator diameter Brush length	28mm 11.5mm	---
Fuel Pump: Fuel pump pressure	330±20KPa	---
Switch: Brake light switch timing of pedal travel Rising temperature	ON after 10 mm (0.4 in.) of pedal travel From OFF to ON at 88°C From ON to OFF at 83.5°C	---

SPECIAL TOOLS

Multimeter



⚠ CAUTION

- ◆ When the multimeter is measuring voltage, the meter pen should not be inserted into the current measuring hole
- ◆ When measuring resistance, please be sure to disconnect the battery positive pole.

Fault diagnosis instrument



BATTERY

REMOVE THE BATTERY

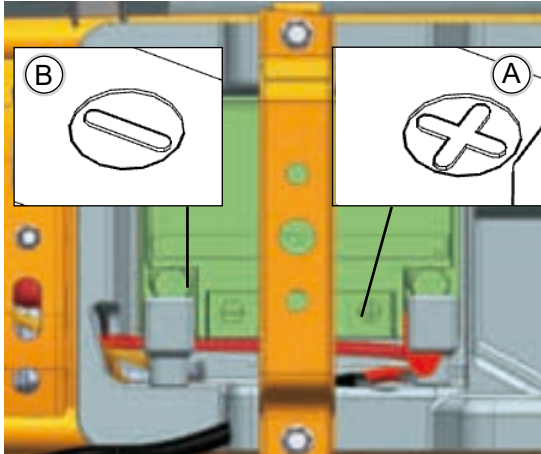

【A】 positive □+□

【B】 negative □-□

- ◆ Turn off ignition switch.
- ◆ Remove seat(Please read frame and body section)
- ◆ Loosen the bolts on the battery seat
- ◆ Remove the battery bracket.
- ◆ First disconnect the battery negative (-) cable, then disconnect the positive (+) cable.
- ◆ Take out the battery

TURN OFF IGNITION SWITCH

- ◆ Place the battery in place with the battery box and retainer.
- ◆ First connect the battery positive (+) cable, then connect the negative (-) cable.
- ◆ Thin grease is applied to the terminals to prevent corrosion.
- ◆ Tighten the battery seat bolts. Match the model name of the battery. These names must be the same.

Battery model Name: GHD32HL-BS



⚠ CAUTION

This battery is a colloidal battery and does not need to add electrolyte.

BATTERY CHARGING

In the case shown in the following table, to start the vehicle fully to start the engine, and it should be charged before use. However, if the battery voltage is higher than 12.6V after 10 minutes of charging, no initial charge is required.

The conditions under which an initial charge is required	charging method
At low temperatures (below 0°C)	1.4 A x 2 _ 3 Hours
Batteries have been stored at high temperatures and in high humidity	1.4 A x 15 _ 20 Hours
The seal has been removed or cracked - flaked, torn or torn	
The battery life is more than 2 years after manufacture	

NOTE: Terminal voltage - To measure the terminal voltage of the battery, use a digital voltmeter. When measuring the terminal voltage after charging, the battery should stand still for more than 20 minutes.

Preventive measures:

1) Colloidal battery, no liquid filling is required

- ◆ Before normal use, there is no need to replenish the battery as long as it is not exhausted. It is very dangerous to pry open the sealing plug and add water. Never do that.

2) Recharge

- ◆ If the engine fails to start, the horn becomes weaker or the indicator light goes dark, it shows the battery is exhausted.
- ◆ Charge the battery for 5 to 10 hours according to the charging current as shown in the specification.
- ◆ When it is inevitable to need quick charging, please charge in strict accordance with the maximum charging current and the time conditions indicated on the battery.

WARNING

The battery is designed to withstand no abnormal damage if it is recharged as specified above. However, if charged under conditions other than those described above, the performance of the battery may degrade significantly. Do not remove the seal cover during recharging. If excess gas is generated due to overcharging, a safety valve ensures battery safety.

3) When you don't use the vehicle for months

- ◆ Before storing the vehicle, please charge it and store it before removing the negative wire.
- ◆ Fully charged once a month during storage.

4) Battery life time

- ◆ If the battery fails to start the engine after several charges, it indicates that the battery has exceeded its service life. Please replace it. (But only if the vehicle itself has no problem starting the system.)

WARNING

During charging, keep the battery away from sparks and naked fire. An explosive gas mixture that releases hydrogen and oxygen. When using a battery charger, connect the battery to the charger before turning on the charger. This process prevents the battery terminals from generating sparks that could ignite any combustible gas. Do not put the fire near the battery and do not loosen the terminal. Electrolytes contain sulfuric acid. Be careful and do not let it come into contact with your skin or eyes. If touched, rinse with plenty of water. If serious, seek medical attention immediately.

Swap places

- ◆ The sealed battery can give full play to its performance only when used in conjunction with appropriate vehicle electrical equipment.
- ◆ Therefore, the sealed battery can only be replaced on the vehicle originally equipped with the tool.
- ◆ If sealed batteries are installed on vehicles with ordinary batteries, please take care of the equipment, the life of sealed batteries will be shortened.

CHARGING CONDITION CHECK

Battery charging status can be measured to check the battery terminal voltage.

- ◆ Remove the battery (refer to the section on Removing the battery).



⚠ WARNING

First, make sure to disconnect the negative (-)

- ◆ Measure the battery terminal voltage.

⚠ CAUTION

The voltage to one decimal point is measured with a readable digital voltmeter 【A】 .

If the reading is below the rated value, it needs to be recharged.

Battery terminal voltage standard: 12.6V or higher

- ◆ Remove the battery (refer to the Removal of batteries section)
- ◆ Recharge the battery in the following way.

⚠ WARNING

The battery is sealed. Do not open it. Do not add water when charging.

The charging current and time are described below.

Terminal voltage: 11.5 _ Less than 12.5 V

Standard charge: 3.2 amps x 5 _ 10 hours

(see attached table)

Quick charge: 32 A x 1.0 hours

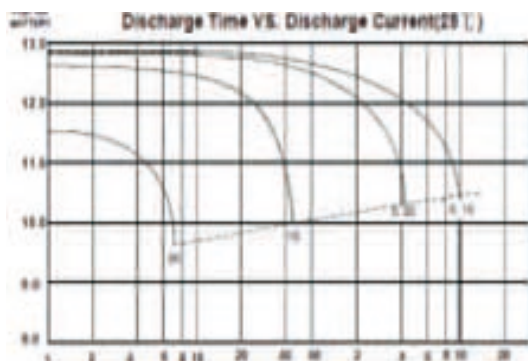

⚠ WARNING

If possible, do not charge quickly. If there is an inevitable situation that requires a quick charge, pay attention to the ambient temperature.

Test against the standard voltage later.

Terminal voltage: less than 11.5V

Charging method: 3.2 A x 20 hours

GENERATOR INSPECTION

There are three types of alternator faults: short circuit, disconnection, or rotor magnetic loss. Short-circuiting one of the coils or disconnecting the wire will result in low output or no output at all. A loss of the magnetic field of the rotor may be caused by a drop or by placing the AC generator near the electromagnetic field, thereby hitting the magnetic field of the AC generator or simply due to aging, resulting in low output. To check the output voltage of the alternator, perform the following procedures.

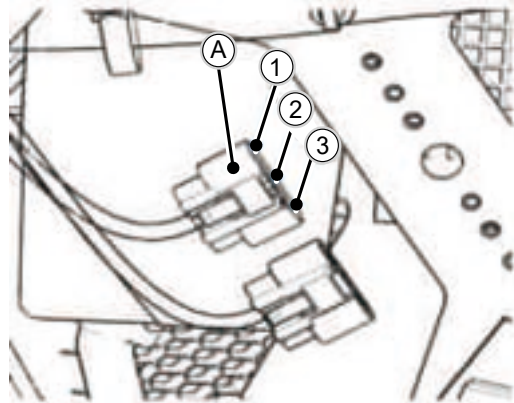

- ◆ Remove rear fender (see Chapter "Frames")
- ◆ Disconnect the alternator connector **【A】** (1, 2, 3 in the connector are magneto three-phase outgoing lines)
- ◆ Connect the handheld tester as shown in the following table
- ◆ Start the engine. Run it at the speed shown in the table. Note the voltage reading (three measurements in total). Ac generator output voltage

Range tester	Tester connection		Reading @3000 rpm
	(+)	(-)	
250 V AC	One Yellow wire	Another Yellow wire	36~54 V

If the output voltage is within the value in the table, the alternator is operating normally and the regulator/rectifier has been damaged. A much lower reading indicates that the AC generator is defective.

Check the stator coil resistance as follows:

- ◆ Stop the engine
- ◆ Disconnect the AC generator connector

Connect the handheld tester as shown in the table below.

Pay attention to the readings (3 measurements in total).

Stator coil resistance



Range tester	Tester connection		Reading @3000 rpm
	(+)	(-)	
$\times 1 \Omega$	One Yellow wire	Another Yellow wire	0.30 _ 0.49 Ω

- ◆ One yellow wire and the other yellow wire if the resistance is greater than that shown in the table, or show nothing. Read the (infinity) of any two wires, the stator has an open circuit and must be replaced. Less resistance means that the stator is short-circuited and must be replaced.
- ◆ Using a handheld tester, measure the resistance between each yellow lead with the engine. Any reading less than infinity must be replaced.
- ◆ If the stator coil has normal resistance, but the voltage check shows that the AC generator is faulty then the rotor magnetism may have weakened and the rotor must be replaced.

CIRCUIT DIAGRAM OF CHARGING SYSTEM

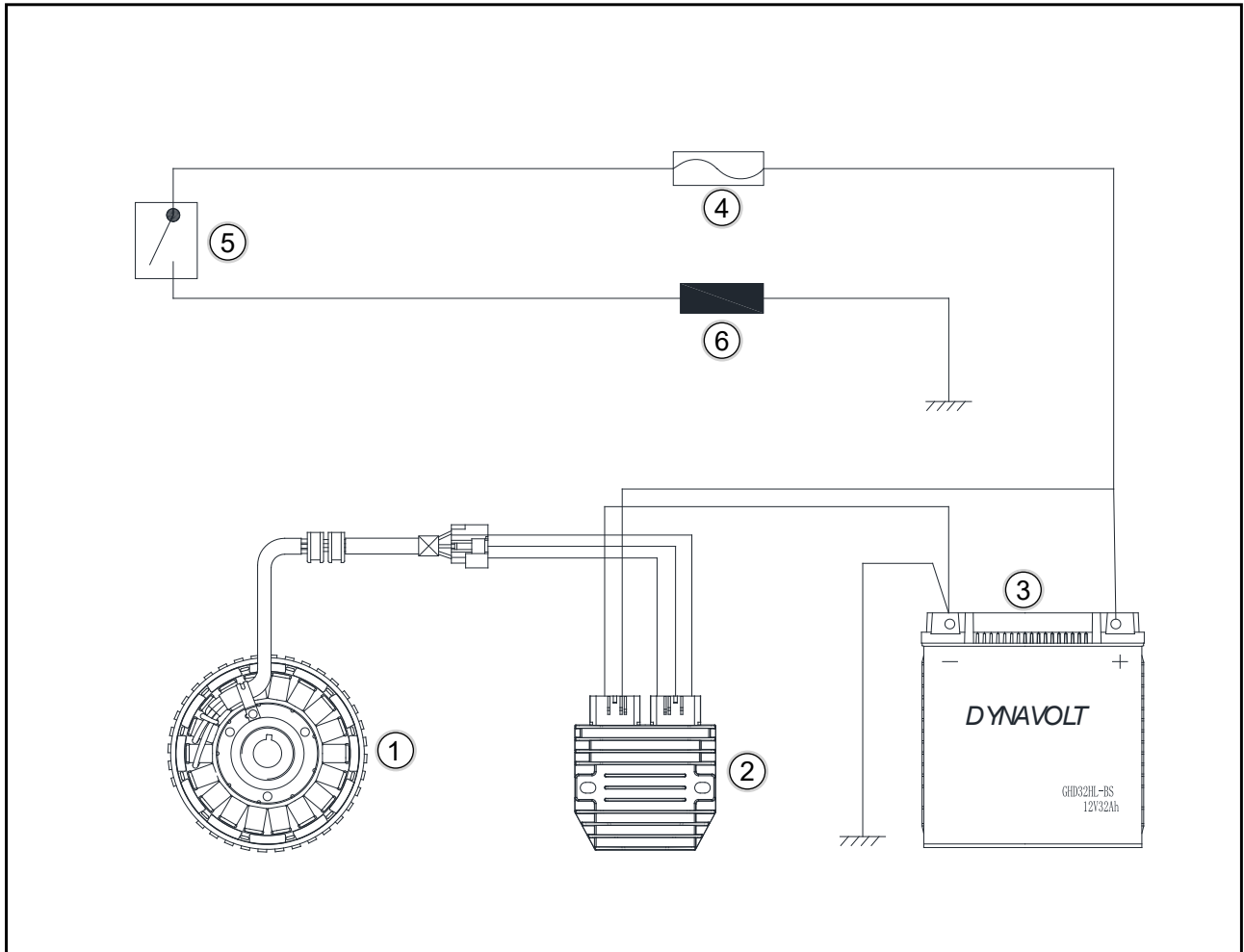

- | | | |
|---------------|------------------------|------------|
| 1. Alternator | 2. regulator/rectifier | 3. Battery |
| 4. Main Fuse | 5. Ignition lock | 6. Load |

VOLTAGE REGULATING RECTIFIER INSPECTION

Test and Judgment Method of Charging Voltage on Whole Vehicle

Test conditions and methods	Output voltage
<ol style="list-style-type: none"> 1. Connect the product according to the normal loading state, after the vehicle started, the speed will remain above 2000rpm; 2. Bring a fully charged battery; 3. Use a multimeter to test the voltage at the output terminal of the regulator 	Output voltage:14.0-15.0V Qualified; otherwise unqualified

REMOVE

- ◆ Connector **【A】** (Disconnect)
- ◆ Bolt **【B】** and Voltage regulating rectifier **【C】**

See the table below for the determination method of the voltage regulating rectifier resistance:

Output resistance characteristics (unit Ω)

Output resistance characteristics (unit Ω)						
	Output +	Y1	Y2	Y3	Output-	Digital multimeter (Diode gear)
Output+		∞	∞	∞	∞	Connect the red pen to output +, and the black test pen to measure the remaining terminals
Y1	0.12-0.25		∞	∞	∞	Connect the red pen to Y1, and the black test pen to measure the remaining terminals
Y2	0.12-0.25	∞		∞	∞	Connect the red pen to Y2, and the black test pen to measure the remaining terminals
Y3	0.12-0.25	∞	∞		∞	Connect the red pen to Y3, and the black test pen to measure the remaining terminals
Output-	0.5-0.7	0.4-0.6	0.4-0.6	0.4-0.6		Connect the red pen to output -, and the black test pen to measure the remaining terminals

EFI SYSTEM

SCHEMATIC DIAGRAM OF EFI SYSTEM

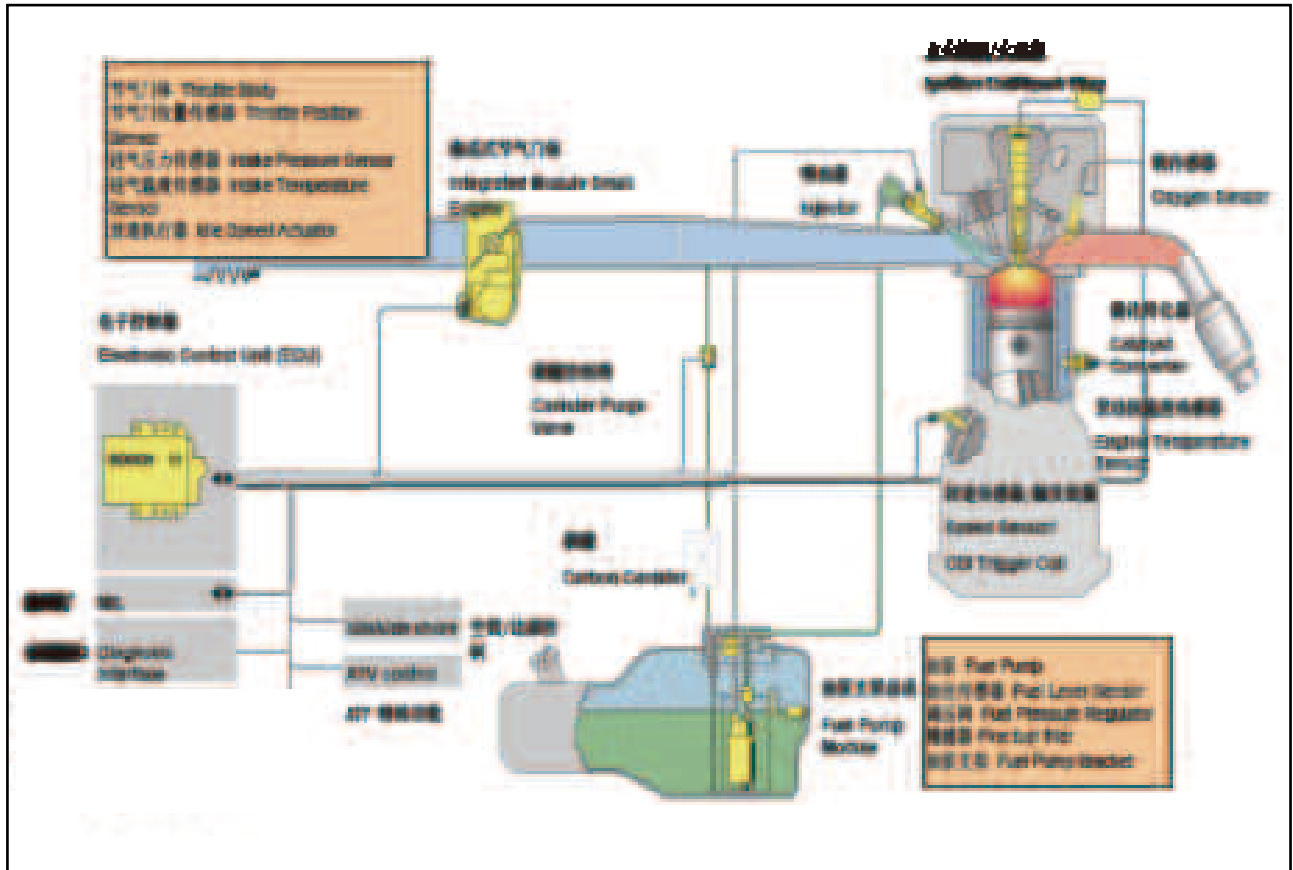

TEMPERATURE SENSOR

FUNCTION INTRODUCTION

The temperature sensor function is used to monitor the temperature of the engine coolant. The sensor delivers engine temperature information to the ECU to determine engine performance and the display. The temperature sensor is generally installed on the intake side of the engine block. The cylinder temperature sensor can be seen by disassembling the left side cover and seat cushion of the whole vehicle (see **【A】** in the figure below).

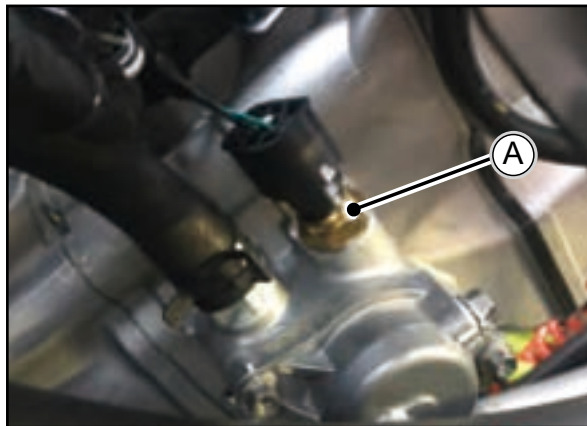

WORKING PRINCIPLE

The NTC thermistor is encapsulated in the temperature sensor, and its resistance value changes with the change of the ambient temperature, so as to accurately and timely measures the small change of the external temperature. The temperature of the contact medium can be reflected by measuring its output resistance. Where, terminal **【A】** and Terminal **【C】** output signals to the electric control unit ECU, and terminal **【B】** is suspended. The stitch definition is shown in the figure below.

【A】 Connect the signal positive **【B】** Suspended **【C】** Connect the negative positive

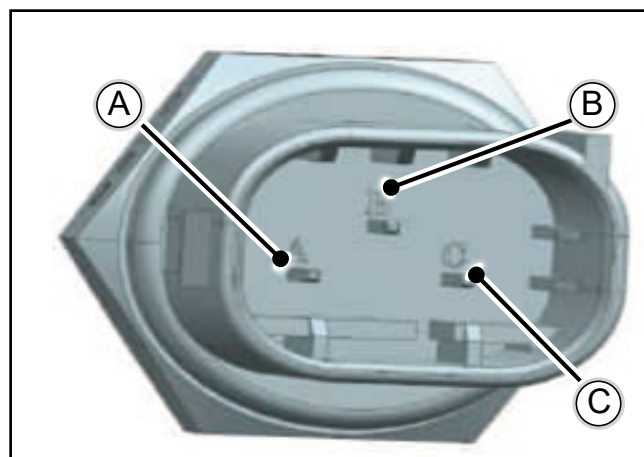

PERFORMANCE PARAMETER

- ◆ **Power: 0.25W under standard use conditions**
- ◆ **Working temperature: -30°C~+130°C**
- ◆ **Vibration level: ≤600m/s²**
- ◆ **Insulation resistance: DC voltage of 500V is applied between the A and C end circuits and the B end circuit, and the insulation resistance is greater than 10MΩ.**
- ◆ **Resistance-temperature characteristics are shown in Table 1**

Table 1 Temperature sensor resistance-temperature characteristics

Temperature range (°C)	A and C end resistances (KΩ)
-20±0.1	13.71~16.49
25±0.1	1.825~2.155
80±0.1	0.303~0.326
110±0.1	0.1383~0.1451
	B end resistances (Ω)
50±0.2	176~280
80±0.2	63.4~81.4
110±0.2	24.6~30.6

FAULT DIAGNOSIS

When the cylinder temperature is greater than its credible upper limit or less than its credible lower limit, the fault flag is set, and the common fault codes are shown in the fault summary table. Cylinder temperature sensor failure check:

- ◆ First check whether the sensor harness connector is well connected
- ◆ Unplug the connector, check whether the sensor and the wire harness end pins are bent or deformed, etc.
- ◆ Use M19mm open-end wrench to remove the sensor and check whether the sensor probe is deformed
- ◆ Check the resistance between pins **【A】** and **【C】**
- ◆ Connect the connector and check the voltage between pins **【A】** and **【C】**

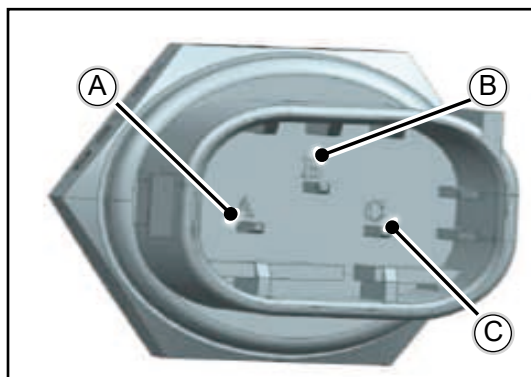

OXYGEN SENSOR

FUNCTION INTRODUCTION

It is used in the feedback system of the electronic control fuel injection device to achieve closed-loop control and improve the control accuracy of the air-fuel ratio of the electronic control unit. It is installed on the exhaust pipe (see **【A】** in the figure below) close to the engine end. It determines whether the gasoline is completely burned by measuring the oxygen content in the exhaust gas to ensure that the three-way catalytic converter has the maximum of HC, CO and NOx in the exhaust gas.

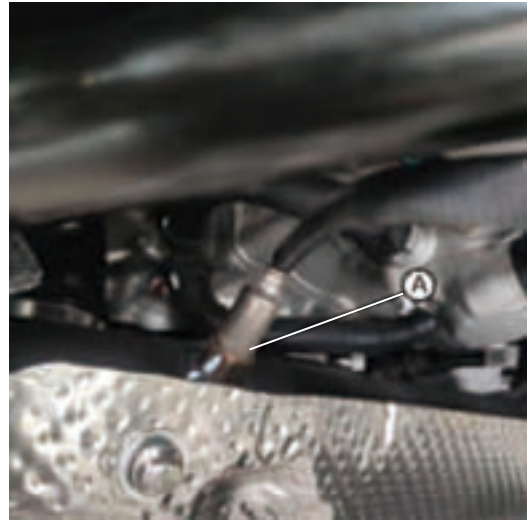

WORKING PRINCIPLE

This is achieved by converting the difference in oxygen concentration inside and outside the sensing ceramic tube into a voltage signal output. When the temperature of the ceramic tube of the sensor reaches 350°C, the ceramic solid electrolyte has conductive properties. The oxygen molecules on both sides of the ceramic are catalyzed into oxygen ions by the platinum electrode of the sensor, and the oxygen ions can move inside the ceramic, therefore, the oxygen on both sides of the ceramic can diffuse through the ceramic itself.

It is this feature that converts the difference in oxygen concentration between the inner and outer sides of the ceramic into a potential difference, thereby forming an electrical signal output. If the mixed gas is thicker and the oxygen concentration in the exhaust gas produced by combustion is low, the oxygen ion concentration difference between the inside and outside of the ceramic tube is higher, the potential difference is higher, a large amount of oxygen ions move from the inside to the outside, and the output voltage is higher (about 800mv --1000mv); if the mixed gas is lean and the oxygen concentration in the exhaust gas produced by combustion is high, the difference in oxygen ion concentration between the inside and outside of the ceramic tube is low, the potential difference is low, the output voltage is low (about 100mv), and the signal voltage is A sudden change occurs near the theoretical equivalent air-fuel ratio ($\lambda=1$).

The oxygen sensor electrical connector has 4 pins:

1. connect to the positive pole of the heating power supply (red)
2. connect to the negative pole of the heating power supply (white)
3. connect to the negative signal of the signal (gray)
4. connect to the positive signal of the signal (black)

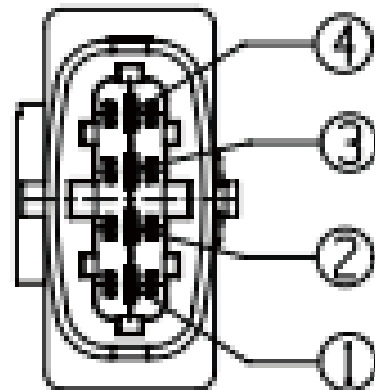

PERFORMANCE PARAMETER

Item	New oxygen		500h Durable after oxygen	
	350°C	850°C	350°C	850°C
Exhaust temperature	350°C	850°C	350°C	850°C
$\lambda = 0.97$ when the sensor element voltage(mv)	840±70	710±70	840±80	710±70
$\lambda = 1.10$ when the sensor element voltage(mv)	20±50	55±30	20±50	40±40
Internal resistance of sensing element (kΩ)	≤1.0	≤0.1	≤1.5	≤0.3
Response time (ms) (600mv-300mv)	≤150	≤150	≤300	≤200
Response time (ms) (300mv-600mv)	≤150	≤150	≤300	≤200

ELECTRICAL CHARACTERISTIC PARAMETER

Item		Value	Unit
Edge resistance between the new sensor heating element and the sensor connector	Ambient temperature, heating element break resistance	≥30	MΩ
	Exhaust temperature 350°C	≥30	MΩ
	Exhaust temperature 850°C	≥30	KΩ
Power supply voltage on plug	Rated voltage	12	V
	Continuous working voltage	12-14	V
	Working voltage that can maintain 1% of total life at most (exhaust temperature ≤850°C)	15	V
	Up to 75s working voltage can be maintained (exhaust temperature ≤350°C)	24	V
	Test voltage	13	V
Working voltage is 13V, heating power when reaching thermal equilibrium (exhaust temperature 350°C, exhaust flow velocity is about 0.7m/s)		12	W
Working voltage is 13V, heating current when ambient temperature is -40°C (exhaust temperature is 350°C, exhaust flow velocity is about 0.7m/s)		5	A
Fuse of heating circuit		8	A

TROUBLESHOOTING

The electronic control unit ECU monitors various sensors, actuators, power amplifier circuits and detection circuits. Common fault codes are shown in the fault list.

⚠ CAUTION

When the fault of oxygen sensor signal is checked, the engine should be run for at least 5-10min to ensure the completion of heating of oxygen sensor.

Oxygen sensor failure check:

- ◆ Check whether the oxygen sensor connector is well connected
- ◆ Unplug the connector, check whether the sensor and the wire harness end pins are bent or deformed, etc.
- ◆ Check whether the resistance between pins 1 and 4 is normal
- ◆ Check whether the voltage between pin 1 and the main relay is normal
- ◆ Connect the connector and run the engine for a period of time, check whether the voltage between pins A and C is normal.

In addition, the oxygen sensor is an indirect reflection sensor. If other sensors are faulty, the oxygen sensor will also report a fault:

- ◆ Unreliable battery voltage
- ◆ The absolute pressure signal of the intake manifold is unreliable
- ◆ The signal of the engine temperature sensor is unreliable
- ◆ Injector driver stage failure

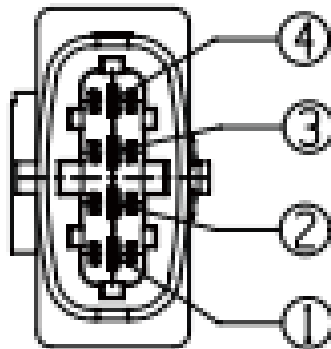

⚠ WARNING

When disassembling the oxygen sensor, be careful of the muffler and engine, and be careful of burns!

CARBON CANISTER SOLENOID VALVE**FUNCTION DESCRIPTION**

The carbon canister solenoid valve is used to control the regeneration gas flow rate of fuel tank vapor flowing through activated carbon. It is triggered by a pulse, and the duration of the pulse or the frequency of the electronic controller is adjusted according to the engine's operating conditions. It is in a closed state when there is no current.

TECHNICAL PARAMETER

Rated voltage and current: 13.5V/0.79A

Working voltage: 9V~16V

Working temperature: -40 °C~140 °C

Resistance (room temperature): 17 Ω

FAULT DIAGNOSIS

When there is a short circuit or open circuit fault in the circuit of the carbon canister solenoid valve, the fault light on the instrument panel will light up and a fault code will appear. Common fault codes can be found in the fault summary table.

1. Check if the wiring harness plug of the carbon canister solenoid valve is properly connected.
2. Unplug the connector to check if there is deformation or pin withdrawal in the carbon canister solenoid valve, harness connector, and ECU connector.
3. Measure whether the resistance of the carbon canister solenoid valve is 17 Ω at room temperature.
4. After unplugging the connector, start the vehicle and measure whether the voltage of circuit 1 at the connector end is between 9V and 16V. After turning off the engine, measure whether circuit 2 is connected to pin 6 of the ECU connector.

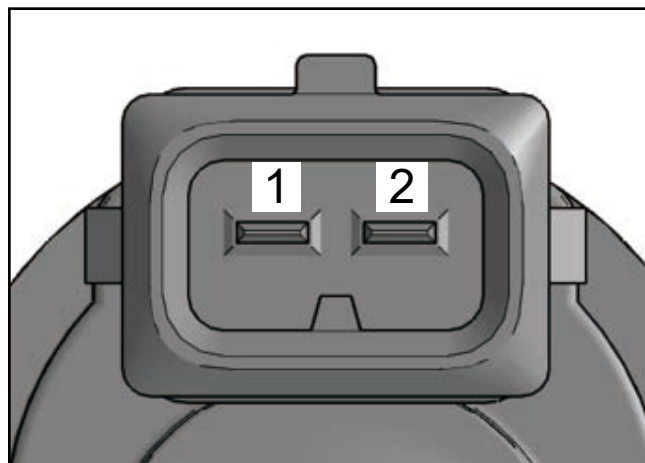

Electronic control unit (ECU)

FUNCTION INTRODUCTION

ECU first collects the running data of the engine system in real time through the sensors of the engine management system, and then drives the actuator to control the engine operation according to the system calibration and the stored calibration data. The ECU is generally installed under the cover (see 【A】 in the figure below) and fixed on the frame by two M6 bolts 【B】 (see 【B】 in the figure below), with the ECU socket facing downwards.

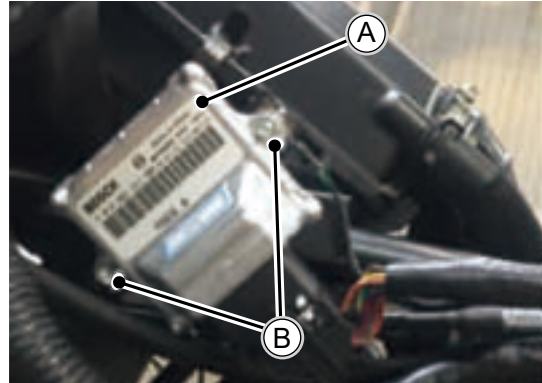

ELECTRICAL CHARACTERISTICS

Working voltage:

Rated voltage: 13.5V

Full functional operating voltage range: 9 V ~ 16 V

Function limited voltage range: 6V ~ 9V, 16V ~ 18V

Ensure the diagnostic function voltage range: 8V ~ 16V

Working current:

Working current : < 1.1 A@13.5v

Static current: <1 mA@13.5v

Electrical protection:

- ◆ Overvoltage protection: ECU can withstand 24V overvoltage for 60 seconds (ambient temperature is $23^{\circ}\text{C} \pm 5^{\circ}\text{C}$). If the system returns to normal operating voltage within 60 seconds, ECU can still ensure normal operation.
- ◆ System reverse voltage protection: If UBR (Pin8) is powered by the main relay, the ECU can withstand a reverse voltage of 14.0 V for 60 seconds (ambient temperature is $23^{\circ}\text{C} \pm 5^{\circ}\text{C}$, other connections are correct), within 60 seconds If the system returns to normal working voltage, ECU can still guarantee normal operation.
- ◆ Output level protection: The controller drive level has diagnostic protection functions, such as short-circuit to ground, short-circuit to power supply and open circuit. But it needs to be pointed out that the ECU ignition pin does not have a short circuit protection function.

FAULT DIAGNOSIS

The No. 34 pin of the ECU is connected to the K line for fault diagnosis. The K line can be used to call up the fault information record in the ECU, or manually input some instructions such as clearing the fault information record, self-learning, etc. ECU failure inspection mainly checks whether the connectors are well connected and whether the pins are bent or deformed.

ECU STITCH DEFINITION

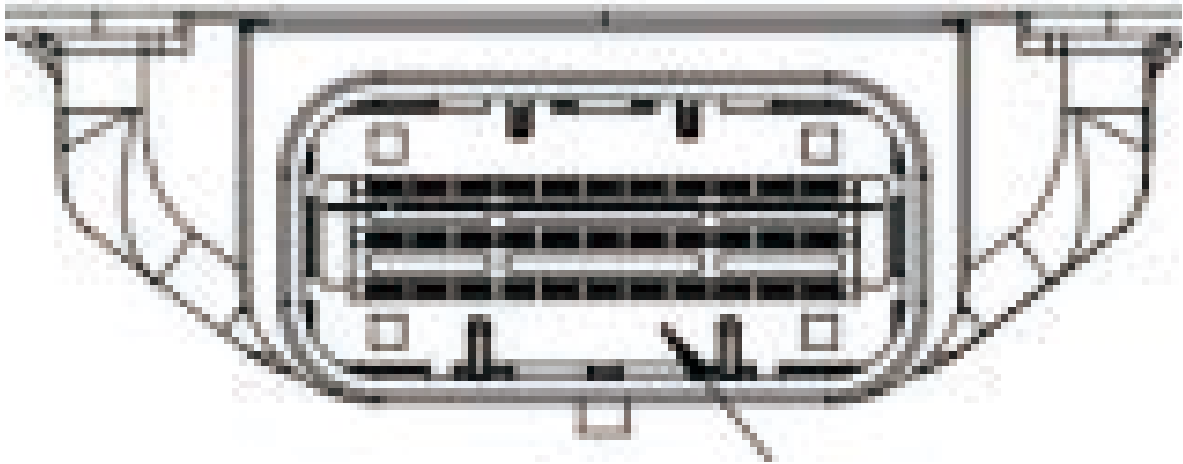

Item	Name	item	Name
1	Oxygen sensor heating	18	Start motor relay
2	Idle motor A	19	Starter relay
3	Vehicle speed signal	20	Upstream Oxygen sensor
4	Continuous power	21	Throttle position sensor
5	Engine speed sensor A end	22	Cooling fan relay
6	Engine speed sensor B end	23	Canister control valve
7	Power ground	24	Idle motor C
8	Intake pressure sensor	25	Idle motor B
9	Engine speed output	26	Ignition switch
10	Power ground 2	27	Sensor ground
11	Ignition coil	28	Fuel pump relay
12	Fuel injector	29	Main relay
13	Idle motor D	30	Brake switch
14	/	31	Force-multiplier switch
15	5V power	32	Engine Coolant temperature sensor
16	CAN low level	33	Intake air temperature sensor
17	CAN high level		

ELECTRONIC THROTTLE BODY DVE SELF-LEARNING PROCESS

1. After replacing either ECU or electronic throttle body, it is necessary to restart the electronic throttle body self-learning;
2. For vehicles that have completed self-learning, turn the key to the ON again, after waiting for 29 seconds, the electronic throttle body self-learning will also be started again.
3. DVE self-learning must meet the following conditions at the same time
 - ① Vehicle speed (vfzg) is 0
 - ② The engine speed (nmotll) is less than 250RPM
 - ③ The engine water temperature (tmot) is between 5.25°C-100.5°C
 - ④ The intake air temperature (tans) is not less than 5.25°C
 - ⑤ Battery voltage (ub) is more than 10V
4. Self-learning operation method:

For the first DVE self-learning, just switch the ignition key to ON and wait for 10 seconds. Do not do anything else at this time.

5. Analysis of possible failures in self-learning and their causes:

If the initial self-learning cannot be completed, the following DVE fault codes may appear:

Fault codes	meaning	Fault light
P1565	DVE mechanical bottom dead center first self-learning failure	Bright SVS/EPC
P1579	Unsatisfactory environmental conditions lead to withdrawal from DVE self-study	—
P1564	The battery voltage condition is not met, which leads to exit DVE self-learning	—

(Note: The above fault codes are only for DVE fault codes recommended by UAES for OEMs. If customers have their own requirements for DVE fault codes, the fault codes may be different)

If the above faults are reported, the dveadchst variable needs to be measured by KIC to confirm what causes the DVE to fail self-learning, and the DVE self-learning can be successfully carried out only after the reasons are identified and eliminated.

dveadchst	The following conditions are not met
24	Engine speed (nmotll) is less than 250RPM
25	Vehicle speed (vfzg) is 0
26	Electronic gas pedal (wped) is 0
27	Battery voltage (ub) is greater than 10V
28	100 °C => engine water temperature (tmot)>=5 °C
30	Inlet air temperature (tans) not less than 5 °C

FUEL INJECTOR

The fuel injector provides fuel to the engine and atomizes it within a specified time according to the instruction of the ECU. The fuel injector is installed on the intake pipe, and the other end is connected to the fuel pipe through the fuel injector cap (see **【A】** in the figure below).



WORKING PRINCIPLE

The ECU sends out electrical pulse signals to the injector coil to form a magnetic field force. When the magnetic field force rises enough to overcome the combined force of the return spring pressure, the gravity of the needle valve and the friction force, the needle valve begins to rise and the fuel injection process begins. The maximum lift of the needle valve does not exceed 0.1mm. When the fuel injection pulse is cut off, the pressure of the return spring causes the needle valve to close again.

PERFORMANCE PARAMETERS

Project	Parameter
Static flow	207.8g/min
Dynamic flow	6.65mg/stroke
Jet angle	23°
Coil resistance	12Ω
Hydraulic leak	1.8mm ³ /min

FAULT DIAGNOSIS

ECU only implements fault diagnosis for the fuel injector drive stage. When the fuel injector drive stage is short-circuited or overloaded to the battery voltage, short-circuited to the ground, or open circuit, the fault flag is set. At this time, close the closed-loop control of the oxygen sensor and its self-learning pre-control. The last self-learning data is valid. After the fault is removed, the fault flag is reset. Common fault codes are shown in the fault summary table

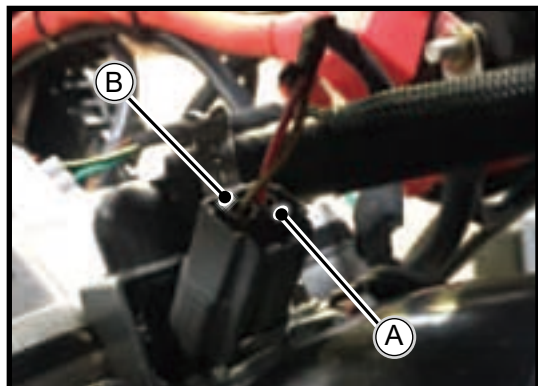

Injector failure inspection:

- ◆ Check the connectors are well connected
- ◆ Check whether the wiring harness and injector pins are bent or deformed
- ◆ Check whether the injector cap and the oil pipe are reliably connected
- ◆ Unplug the connector and check the coil resistance between pins A and B
- ◆ Check the resistance between the pins (A on the left figure) and the main relay
- ◆ Check the resistance between the pins (B in the left figure) and ECU pin 12 (see ECU pin definition)

! WARNING

When removing the fuel pipe, there is high-pressure fuel in the fuel pipe. Pay attention to fire safety and spray it into your eyes carefully.

IGNITION COILS

The ignition coil converts the low-voltage electricity of the primary winding into the high-voltage electricity of the secondary winding, and generates sparks through the discharge of the spark plug to ignite the fuel-air mixture in the gas cylinder.

The ignition coil is installed on the engine. Remove the seat cushion to see the ignition coil installed on the engine (see **【A】** in the figure below).

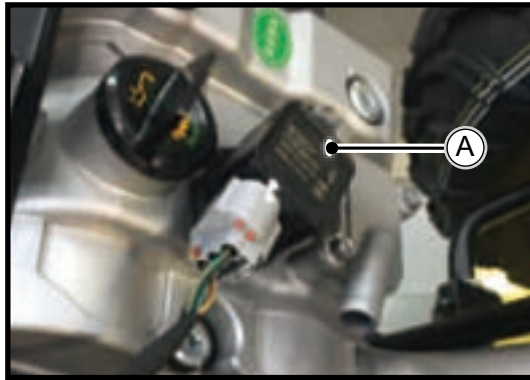

WORKING PRINCIPLE

The ignition coil is composed of a primary winding, a secondary winding, an iron core, and a shell. When the battery voltage is applied to the primary winding, the primary winding is charged, once the ECU cuts off the primary winding loop, the charging is stopped and high voltage is induced in the secondary winding.

There are 3 pins on the low voltage side of the ignition coil:

- ◆ PIN 1: Connect to ECU control signal
- ◆ PIN 2: Pin Ground
- ◆ PIN 3: Connect to the positive terminal of the battery

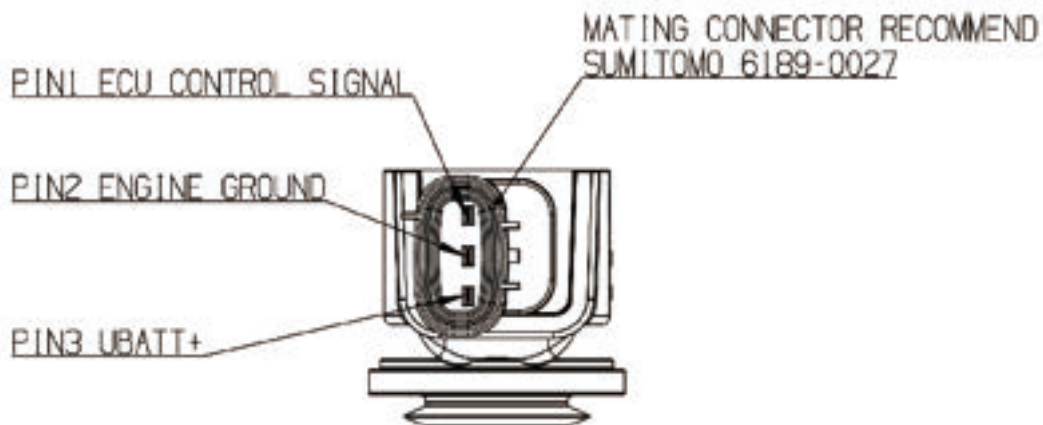

PERFORMANCE PARAMETERS

Item		Value			Unit
		Min	Rated	Max	
Calibration voltage		/	14	/	V
Operating voltage		6	14	16.5	V
Resistance (20--25°C)	Primary winding	466	530	593	mΩ
	Secondary winding	8.27	9.4	10.53	kΩ
Primary current (Charging time 3.9ms)		7.4	8.0	8.6	A
Secondary voltage (Load 35pF)		34	/	/	kV
Ignition energy (Zener voltage 1000V)		40	/	/	mJ

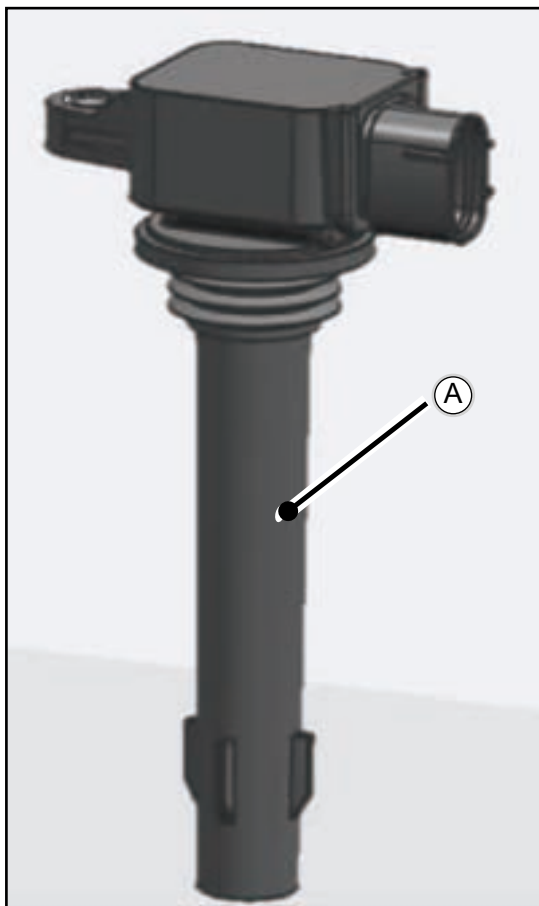

FAULT DIAGNOSIS

The ECU does not perform the fault diagnosis function for the ignition coil, so there is no ignition coil related code in the fault code list. If there is no ignition, please check whether the ignition coil connector is well connected, whether the pins are deformed, and whether the ignition coil wire and the spark plug are in good contact.

⚠ WARNING

If the spark plug wire (point **A** in the left picture) is installed incorrectly, it will cause the engine to shut down.

火花塞

The spark plug introduces the pulsed high voltage electricity generated by the ignition coil into the combustion chamber, and uses the electric spark generated by the electrode to ignite the mixture to complete the combustion. The spark plug sample diagram (see the figure below).

! WARNING

If the spark plug gap (point **A**) in the left picture) is outside the range of 0.7 ± 0.1 , it will lead to unreliable ignition or failure to ignite. Please adjust the gap or replace the spark plug in time

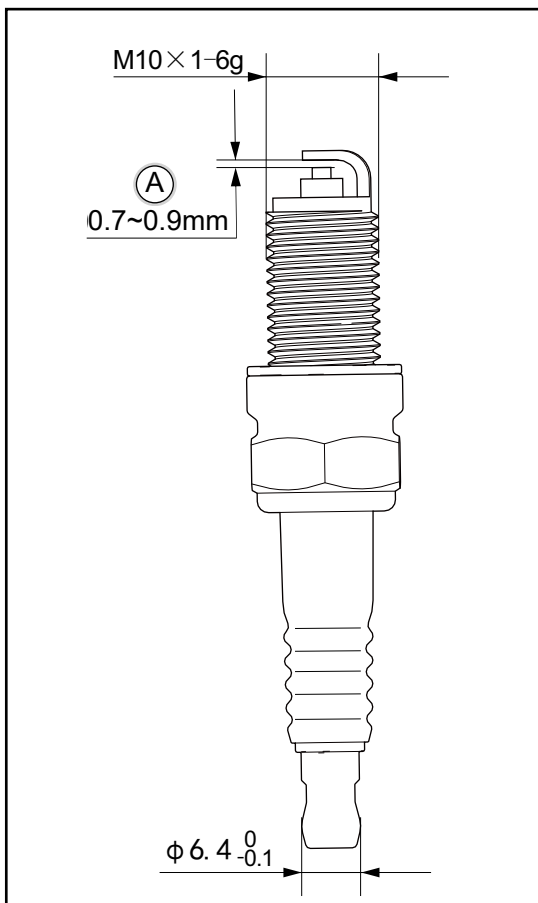
**REMOVE AND INSTALL SPARK PLUGS**

- ◆ Remove the ignition coil
- ◆ Use the spark plug sleeve to remove the spark plug
- ◆ Take out the spark plug and check the state of the spark plug
- ◆ If there is no problem, please replace with a new spark plug

Spark plug torque

15N · m (1.5kgf·m, 11.1ft·lb)

! CAUTION

In the process of disassembly and installation, be careful not to hit the spark plug against any hard objects such as the engine block. If so, please replace with new spark plugs in time.

ENGINE SPEED SENSOR

The working principle of the speed sensor is to use the magnetoelectric effect. When the shaft rotates, the signal wheel is driven to rotate together, and the teeth on the signal wheel will cut the magnetic line of the sensor. This change in magnetic flux causes a certain frequency at both ends of the sensor coil. The output voltage is output to the electronic controller, and the output signal can represent the crankshaft speed and position (see A in the figure below).

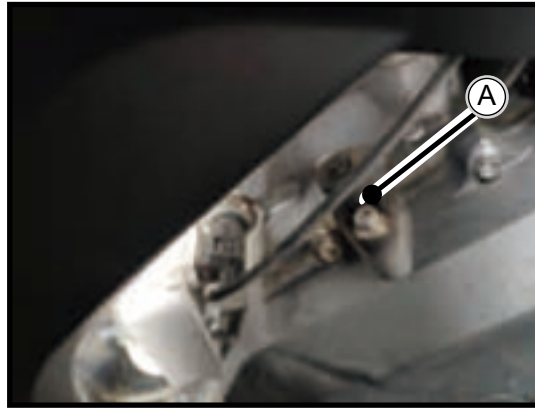

TECHNICAL PERFORMANCE TEST

The speed sensor outputs a sinusoidal voltage signal, and the output signal (see **【B】** on the left)

Coil resistance (23 °C) : 950-20 Ω

Coil inductance (1000HZ) : 450±15 mH

FAULT DIAGNOSIS

- ◆ When the engine cannot be started, the remaining fault points have been eliminated. Use a multimeter to test whether the coil resistance of the speed sensor is the resistance required by the technical performance.
- ◆ If the resistance value is normal, please use an oscilloscope to check whether the voltage signal output by the sensor is as shown in the figure (B in the left figure)

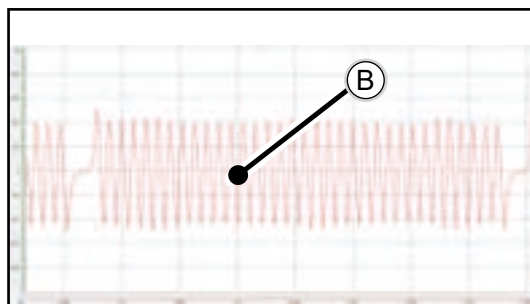

⚠ CAUTION

When the two pins of the sensor are connected reversely, the first gear signal after the missing gear in the output voltage signal is negative, which will cause the engine to be turbulent, idling unstable or unable to start.

OIL PRESSURE SENSOR

The oil pressure sensor detects the size of the engine oil pressure when it is working, and it is usually screwed into the oil passage of the cylinder block. Its working principle is that there is a variable resistor inside the sensor, one end outputs the signal, and the other end is connected to the grounded sliding arm. When the oil pressure increases, the oil pressure pushes the diaphragm through the lubricating oil channel interface to bend, and the diaphragm pushes the sliding arm to a low resistance position, which increases the output current in the circuit, and vice versa, reduces the output current in the circuit. (See 【A】 in the figure below). The sensor is a normally open contact, the working pressure is $250\pm 10\text{kPa}$, and the maximum working temperature is greater than 150°C . When the oil pressure is too low, the oil pressure indicator on the instrument is always on.



FAULT DIAGNOSIS

1. When there is no oil pressure indicator, it is generally because the wiring harness connector is poorly connected.
2. When the wiring harness connector is well connected, the sensor itself is faulty. It is recommended to replace the sensor with a new one.

! WARNING

When an oil pressure failure occurs, you must troubleshoot the failure. Forcible operation will damage the engine.

THROTTLE VALVE BODY ASSEMBLY

The throttle valve body assembly is connected to the engine and the air filter. The user can control the opening and closing angle of the throttle valve through the throttle cable to achieve different driving intentions. The structure and size of the main passage of the throttle body are directly related to the amount of air entering the engine, and the performance of the engine at different speeds can be changed by changing the main passage. The valve body assembly includes: a mechanical throttle body assembly, a three-in-one sensor (intake pressure, intake temperature and throttle position sensor) and a stepper motor

Disassemble the entire vehicle seat cushion and left side cover to see the throttle valve body assembly(See A on the left)

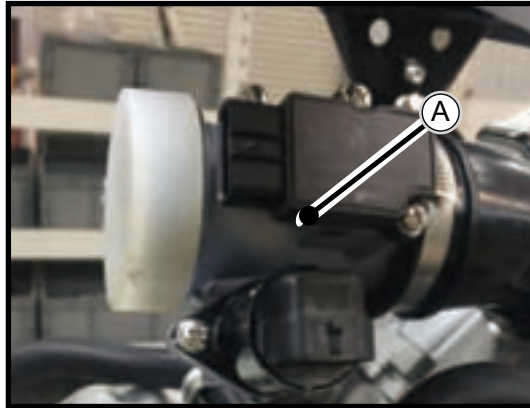

THREE-IN-ONE SENSOR

The three-in-one sensor includes: intake pressure, intake temperature and throttle position sensor. The pin diagram is shown on the left.

Vp: intake pressure signal; Vin: 5V power supply;

GND: sensor ground; Vtps: throttle position signal;

Ts: intake air temperature signal;

The core of the intake air temperature sensor is the thermistor that responds quickly to temperature. The intake air pressure sensor communicates with the main channel of the throttle body through the air pressure channel on the throttle body to detect the absolute pressure of the intake air. When the pressure in the main channel changes, the output voltage of the pressure chip will also change accordingly. Through the corresponding relationship between the output voltage and the absolute pressure of the main channel, the ECU can obtain the absolute pressure value of the main channel at this time. The throttle position sensor is an angle sensor with linear output, composed of two arc-shaped sliding contact resistors and two sliding contact arms. The rotating shaft of the sliding contact arm and the throttle body shaft are connected on the same axis. A voltage of 5V is applied to both ends of the sliding contact resistance. When the throttle valve rotates, the sliding contact arm rotates and moves on the sliding contact resistance at the same time, and outputs the potential of the contact as a voltage, which is actually a corner potentiometer.

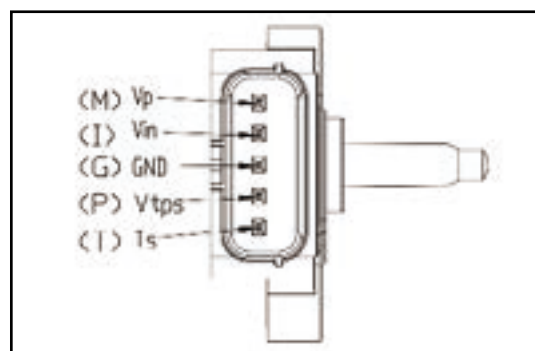

THREE-IN-ONE SENSOR PERFORMANCE CHARACTERISTICS

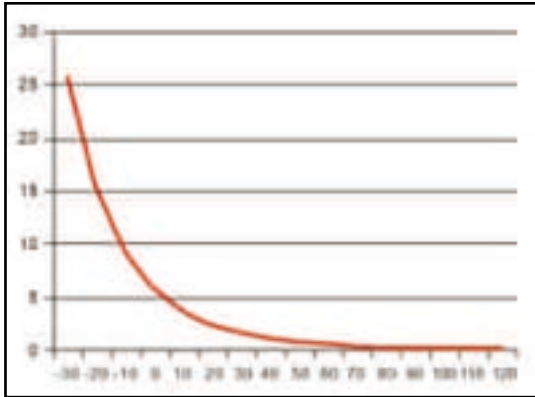

Intake temperature sensor	
R25	2kΩ±3%
B25/85	3520k±2%
Temperature-resistance characteristics	See the left picture

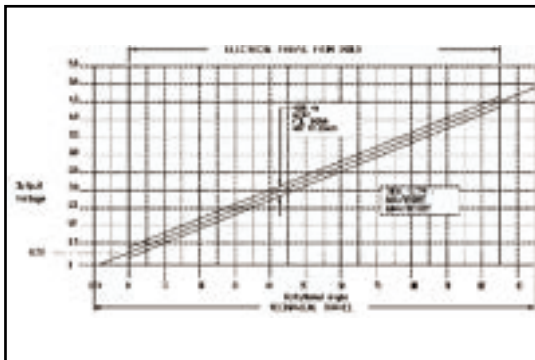

Throttle position sensor	
Linearity	See the left picture
Operating temperature	-30°C --+110°C

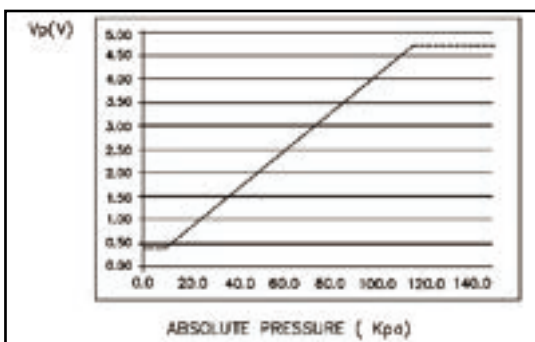

Intake pressure sensor	
Change sensitivity	40.5mV/kPa
Output voltage characteristic	See the left picture

IDLE MOTOR

The idle motor is composed of a plurality of steel stators and rotors arranged in a circle. Each steel stator is wound with a coil; the rotor is a permanent magnet, and the center of the permanent magnet is a nut. All stator coils are always energized. As long as the current direction of one of the coils is changed, the rotor will rotate through an angle. When each stator coil changes the direction of current in the proper sequence, a rotating magnetic field is formed, which makes the rotor made of permanent magnets rotate in a certain direction. If the order of the current direction changes is reversed, the direction of rotation of the rotor will also be reversed. The nut connected to the center of the rotor drives a screw rod. Because the screw rod is designed to be unable to rotate, it can only move in the axial direction, so it is also called a linear axis. The end of the screw rod is a plug, so the plug can be retracted or extended to increase or decrease the cross-sectional area of the bypass air inlet passage of the idle speed actuator until it is blocked. Whenever the current direction of a certain coil is changed, the rotor rotates through a fixed angle, called the step length, which is equal to 360° divided by the number of stators or coils. Correspondingly, the distance the screw rod moves in each step is also fixed. The ECU controls the number of moving steps of the idle motor by controlling the number of times the current direction of the coil is replaced, thereby adjusting the cross-sectional area of the bypass channel and the air flow through it. The idle motor is installed on the throttle valve body (see **[A]** on the left), and the probe of the idle motor is generally flat or down.

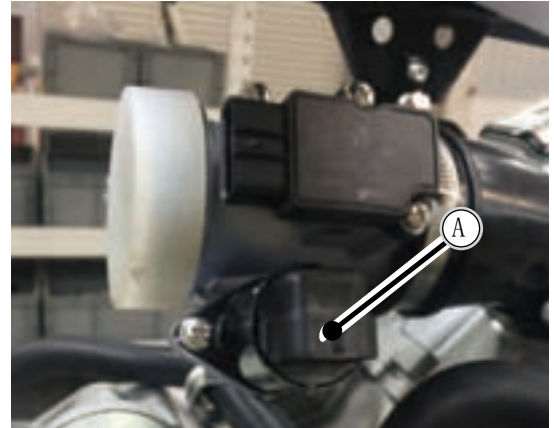

The nut connected to the center of the rotor drives a screw rod. Because the screw rod is designed to be unable to rotate, it can only move in the axial direction, so it is also called a linear axis. The end of the screw rod is a plug, so the plug can be retracted or extended to increase or decrease the cross-sectional area of the bypass air inlet passage of the idle speed actuator until it is blocked. Whenever the current direction of a certain coil is changed, the rotor rotates through a fixed angle, called the step length, which is equal to 360° divided by the number of stators or coils. Correspondingly, the distance the screw rod moves in each step is also fixed. The ECU controls the number of moving steps of the idle motor by controlling the number of times the current direction of the coil is replaced, thereby adjusting the cross-sectional area of the bypass channel and the air flow through it. The idle motor is installed on the throttle valve body (see **[A]** on the left), and the probe of the idle motor is generally flat or down.

Idle motor pin definition:

- [A]** Idle motor phase A
- [B]** Idle motor phase B
- [C]** Idle motor phase C
- [D]** Idle motor phase D

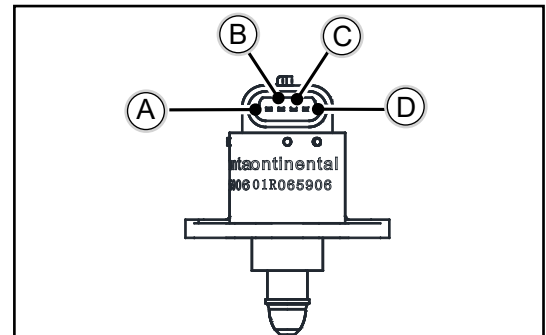

⚠ WARNING

The idle motor probe cannot be placed on top, which may cause loss of step, resulting in unstable idling or even stalling of the vehicle.

IDLE MOTOR FLOW CHARACTERISTICS

The ECU controls the number of moving steps of the stepper motor by controlling the number of times the current direction of the coil is replaced, thereby adjusting the cross-sectional area of the bypass channel and the air flow through it. The flow characteristics of stepper motors are shown on the left.

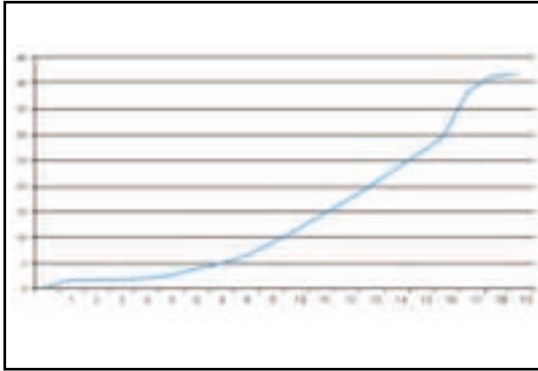

FAULT DIAGNOSIS

ECU monitors various sensors, actuators, power amplifier circuits and detection circuits. Common fault codes are shown in the fault summary table:

Three-in-one sensor fault inspection:

- ◆ Check that the connector is well connected
- ◆ Check whether the wiring harness and injector pins are bent or deformed
- ◆ Measure the resistance between M pin and pin G
- ◆ Measure the voltage of M pin and ECU pin
- ◆ Measure the resistance of T pin and pin G
- ◆ Measure the resistance of P pin and pin G

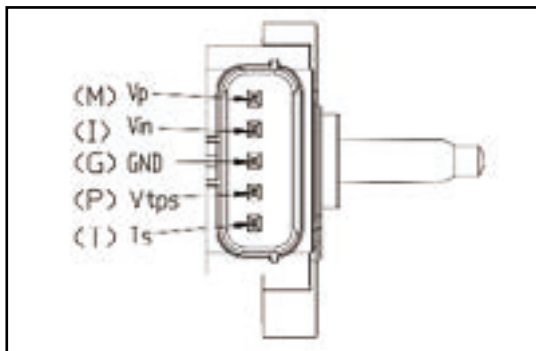

IDLE MOTOR FAULT CHECK:

- ◆ Check that the connector is well connected
- ◆ Check whether the wiring harness and injector pins are bent or deformed
- ◆ Measure the resistance or voltage between each stepping motor drive circuit connected to the ECU and the ground

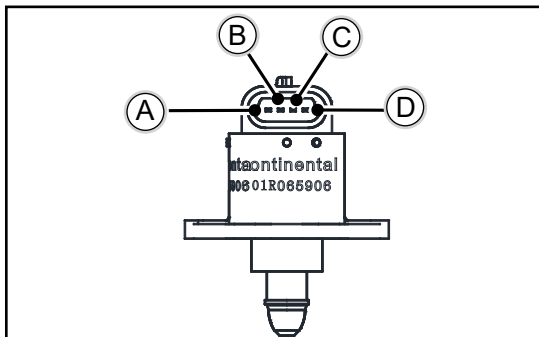

FAULT CODE READING

There is a fault indicator (【A】 in the left figure) in the instrument. When the key switch is turned on, the fault indicator is always on. When the engine is running, if the vehicle electronically controlled fuel injection system has no faults, the indicator light should go out; if there is a fault, the indicator light should always be on, indicating that the system is faulty. The indicator (【B】 in the left figure) can display the relevant fault code, and the specific fault information can be queried through the fault code summary table.

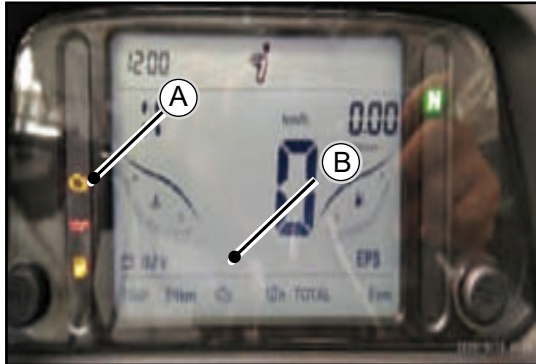

TROUBLESHOOTER OPERATION

When the engine is running, the instrument fault indicator is always on, indicating that the system is faulty. At present, use a dedicated fault diagnosis instrument (bottom left) to read the corresponding fault information. Use the OBD diagnostic interface to connect to the corresponding diagnostic interface of the vehicle, and connect the other end of the device to the computer (diagnostic software and corresponding drivers should be installed on the computer), and the key switch should be turned on. Specific steps:



- ◆ Connect the device, select "Open CAN", and press the OK button.
- ◆ Enter the main interface, you can view engine operating parameters and fault information



⚠ CAUTION

When the engine is not running, it is normal that the fault light is always on, and there is no need to deal with it

SUMMARY OF FAILURE CODES (ECU)

NO.	Pcode	Description (UAES)	fault indicator on
1	P0030	O2 Sensor 1 Heater Contr. Circ. High	√
2	P0031	O2 Sensor 1 Heater Contr. Circ. Low	√
3	P0032	O2 Sensor 1 Heater Contr. Circ. Open	√
4	P0107	Manifold Abs.Pressure or Bar.Pressure Low Input	√
5	P0108	Manifold Abs.Pressure or Bar.Pressure High Input	√
6	P0112	Intake Air Temp.Circ. Low Input	√
7	P0113	Intake Air Temp.Circ. High Input	√
8	P0117	Engine Coolant Temp.Circ. Low Input	√
9	P0118	Engine Coolant Temp.Circ. High Input	√
10	P0122	Throttle Pos.Sensor Circ. Low Input	√
11	P0123	Throttle Pos.Sensor Circ. High Input	√
12	P0130	O2 Sensor Circ.,Bank1-Sensor1 Malfunction	√
13	P0131	O2 Sensor Circ.,Bank1-Sensor1 low Voltage	√
14	P0132	O2 Sensor Circ.,Bank1-Sensor1 High Voltage	√
15	P0134	O2 Sensor Circ.,Bank1-Sensor1 No Activity Detected	√
16	P0201	Cylinder 1- Injector Circuit	√
17	P2300	点火线圈对地短路故障	
18	P0261	Cylinder 1- Injector Circuit Low	√
19	P0262	Cylinder 1- Injector Circuit High	√
20	P0322	Ign./Distributor Eng.Speed Inp.Circ. No Signal	√
21	P0480	cooling fan control Circuit Open	√
22	P0501	Vehicle Speed Sensor "A" Range/Performance	√
23	P0508	Idle Air Control Circuit Low	√

NO.	Pcode	Description (UAES)	fault indicator on
24	P0509	Idle Air Control Circuit Low High	√
25	P0511	Idle Air Control Circuit Open	√
26	P0560	System Voltage Malfunction	√
27	P0562	System Voltage Low Voltage	√
28	P0563	System Voltage High Voltage	√
29	P0627	Fuel Pump "A" Control Circuit /Open	√
30	P0628	Fuel Pump "A" Control Circuit Low	√
31	P0629	Fuel Pump "A" Control Circuit High	√
32	P0650	Malfunction Indicator Lamp Control Circ.	√
33	P0691	cooling fan control Circuit Low	√
34	P0692	cooling fan control Circuit High	√

LIGHTING SYSTEM CIRCUIT

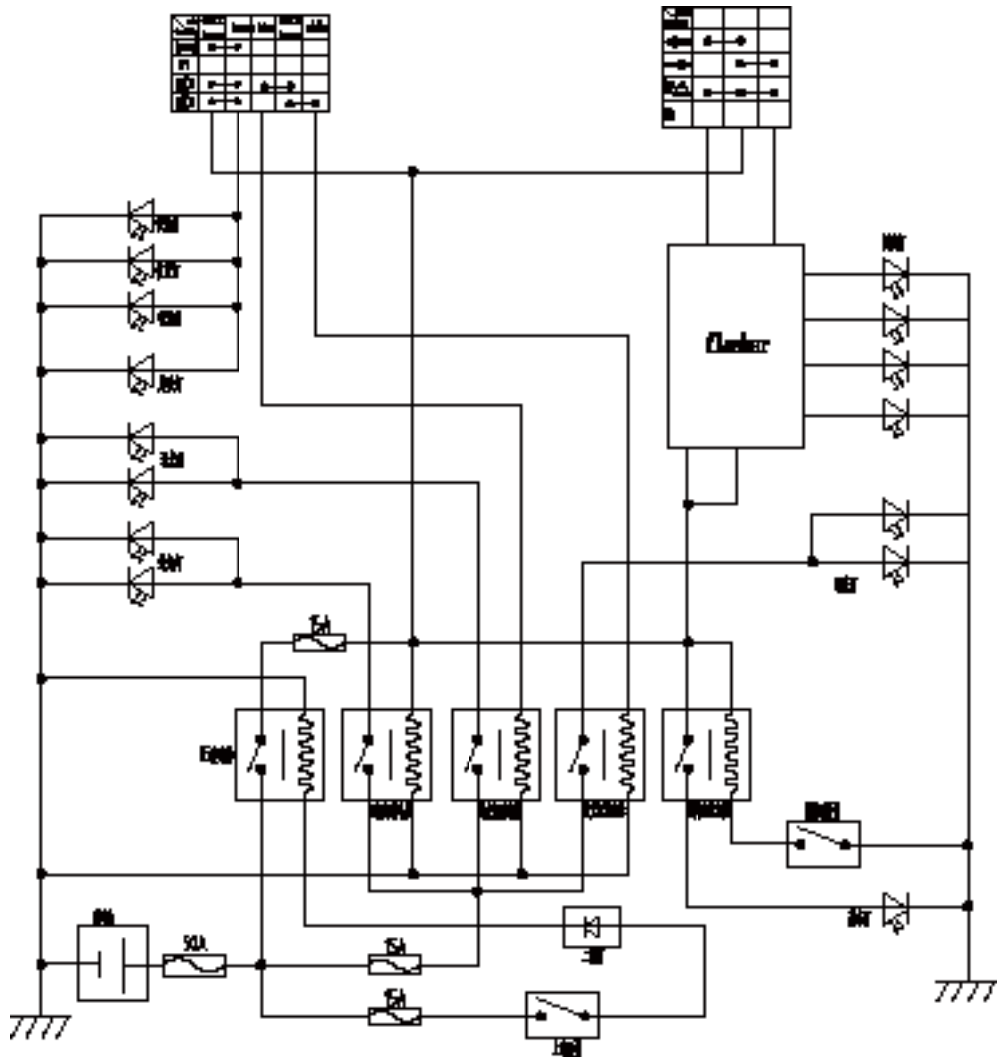

1	Battery	2	Main Fuse	3	Fuse 15A	4	Fuse 15A
5	Lgnition lock	6	Diode	7	Brake lamp relay	8	Brake SW
9	Brake relay	10	Low beam relay	11	High beam relay	12	Daytime running light relay
13	IG relay	14	Fuse 15A	15	Daytime running light	16	High beam
17	License plate lamp	18	Position lights	19	Lights switch	20	turn switch
21	Flash CM	22	turn sLights	23	Low beam		

HEADLAMPS

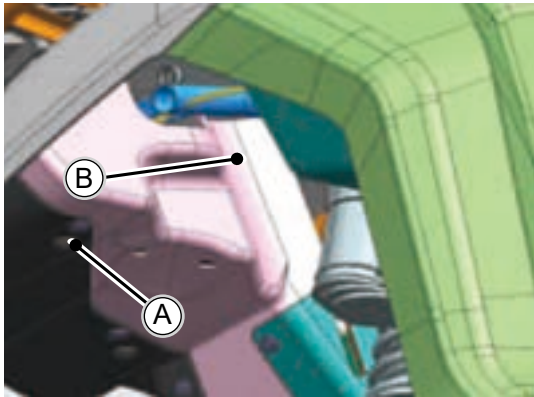

Headlamp rear guard (see chapter "Frame")

- 【A】 Mounting clips
- 【B】 Headlamp rear guard
- 【C】 Headlamp body
- 【D】 Headlamp bolts *4
- 【E】 Adjustment bolts for high and low beam

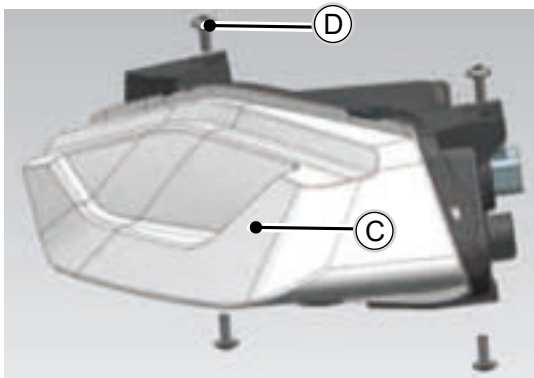

REPLACE

⚠ CAUTION

- ◆ Lamps are LED lamps;
 - ◆ LED headlamp high and low beam is damaged, can only replace the headlamp;
 - ◆ Other light sources are damaged, also can only replace the headlamp.
-
- ◆ Remove the clips on the headlamp rear guard 【A】 .
 - ◆ Remove the headlamp rear guard 【B】 .
 - ◆ Remove the 4 headlamp bolts 【D】 with tools, unplug the headlamp connector and remove the headlamp body 【C】 .
 - ◆ After replacing the headlamps, adjust the headlamp beam height to a suitable position.

TAIL LAMP

TAIL LAMP 1

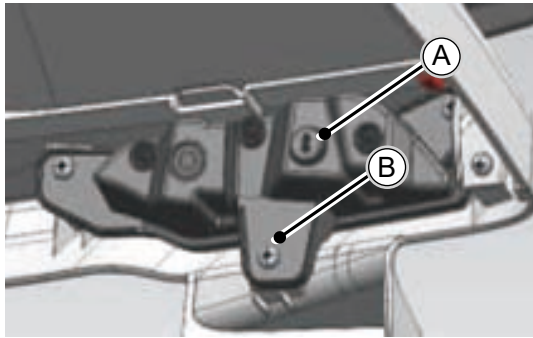

- 【A】 Tail lamp body
- 【B】 Tail lamp bolts*3、

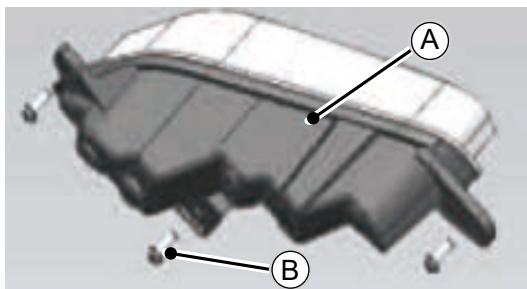

TAIL LAMP 2

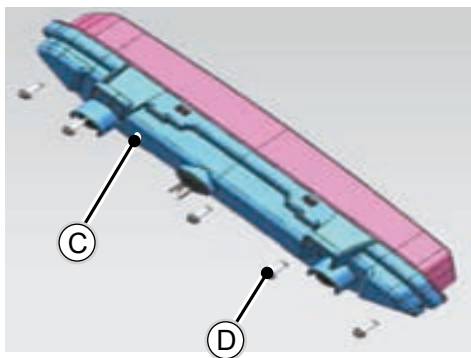

- 【C】 Tail lamp body
- 【D】 Tail lamp bolts*5

Replace

⚠ CAUTION

Lamps are LED lamps

LED tail lamp source damaged, only tail lamps assembly can be replaced

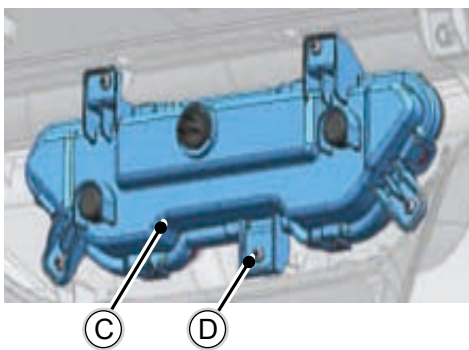

- ◆ Remove the tail light rear screws 【B】 【D】
- ◆ Remove the tail light 【A】 【B】 .
- ◆ Remove the tail light body after unplugging the tail light connector.

The assembly should be performed in reverse order as above

LICENSE PLATE LAMP

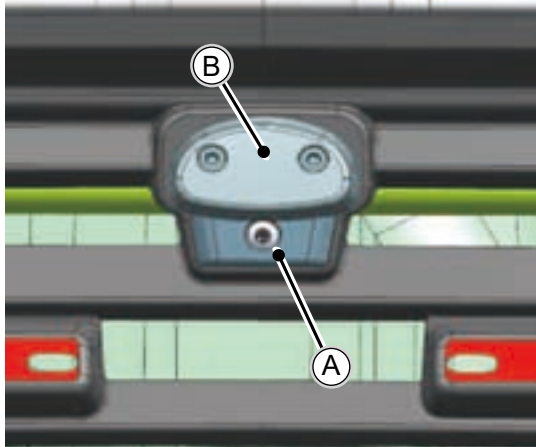

【A】 License plate lamp bolt*1

【B】 License plate lamp

REMOVE

- ◆ Remove the license plate lamp bolt 【A】
- ◆ Remove the license plate lamp 【B】
- ◆ Disassembly license plate lamp灯

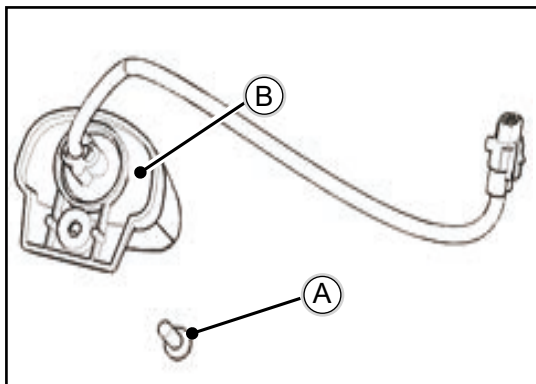

REPLACEMENT ASSEMBLY

The assembly should be performed in the reverse order as above

⚠ CAUTION

- ◆ License plate lamp is LED lamp
- ◆ LED license plate lamp source damaged, only license plate lamp assembly can be replaced

FLASHER

Disassembly and assembly of the front shelf and front guard (please refer to the relevant sections of the body)

【A】 rubber sleeve

【B】 Flasher

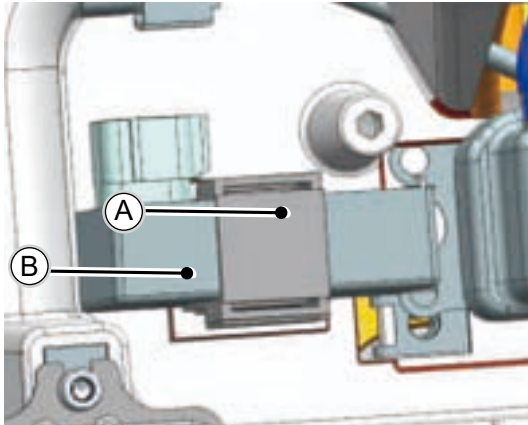

DISASSEMBLY

- ◆ Remove the installation rubber sleeve 【A】 from the installation bracket
- ◆ Remove the wiring harness connector
- ◆ Replace the flasher 【B】

→ TEST

- ◆ If the turn signal does not flash or flashes abnormally on the whole vehicle (the normal turn signal flash frequency is 85/min)
- ◆ The lamp is out of light (one-side forward or backward turn light is damaged), and the turn signal flashes at a frequency of 120/min)

EPS-BRUSHLESS

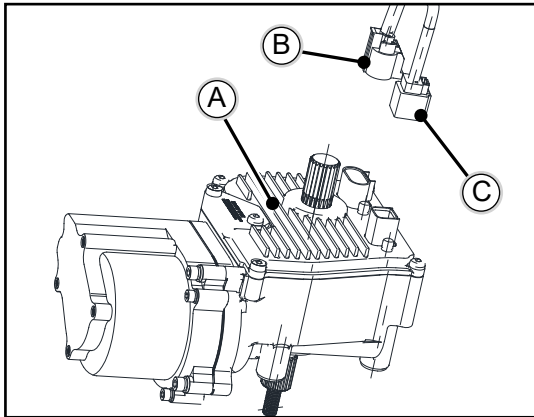

⚠ CAUTION

The method of disassembling the EPS assembly refers to the method of disassembling the steering assembly. Only the electrical functions of the EPS are introduced here.

Before disassembling the EPS assembly **【A】**, firstly remove the power connector **【B】** and power connector **【C】**

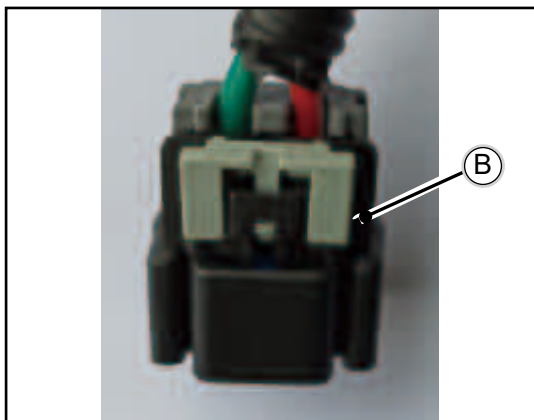

The interface of the plug **【B】** is defined as follows

- ◆ G means green wire, wire diameter 5.0, for grounding
- ◆ RW means red white wire, wire diameter 5.0, 12V+

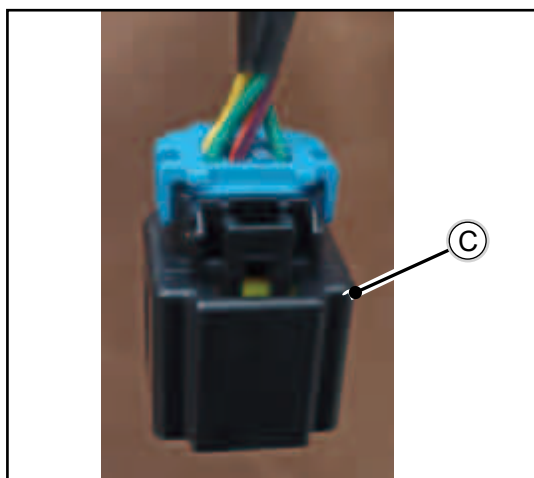

The interface of the plug **【C】** is defined as follows

- ◆ G means green wire, the wire diameter is 0.5, CANL
- ◆ Y means yellow wire, wire diameter 0.5, CANH
- ◆ OV means orange-purple wire, wire diameter 0.5, 12V+ for key power
- ◆ G means green wire, wire diameter 0.5, for grounding

EPS SYSTEM WIRING SCHEMATIC DIAGRAM

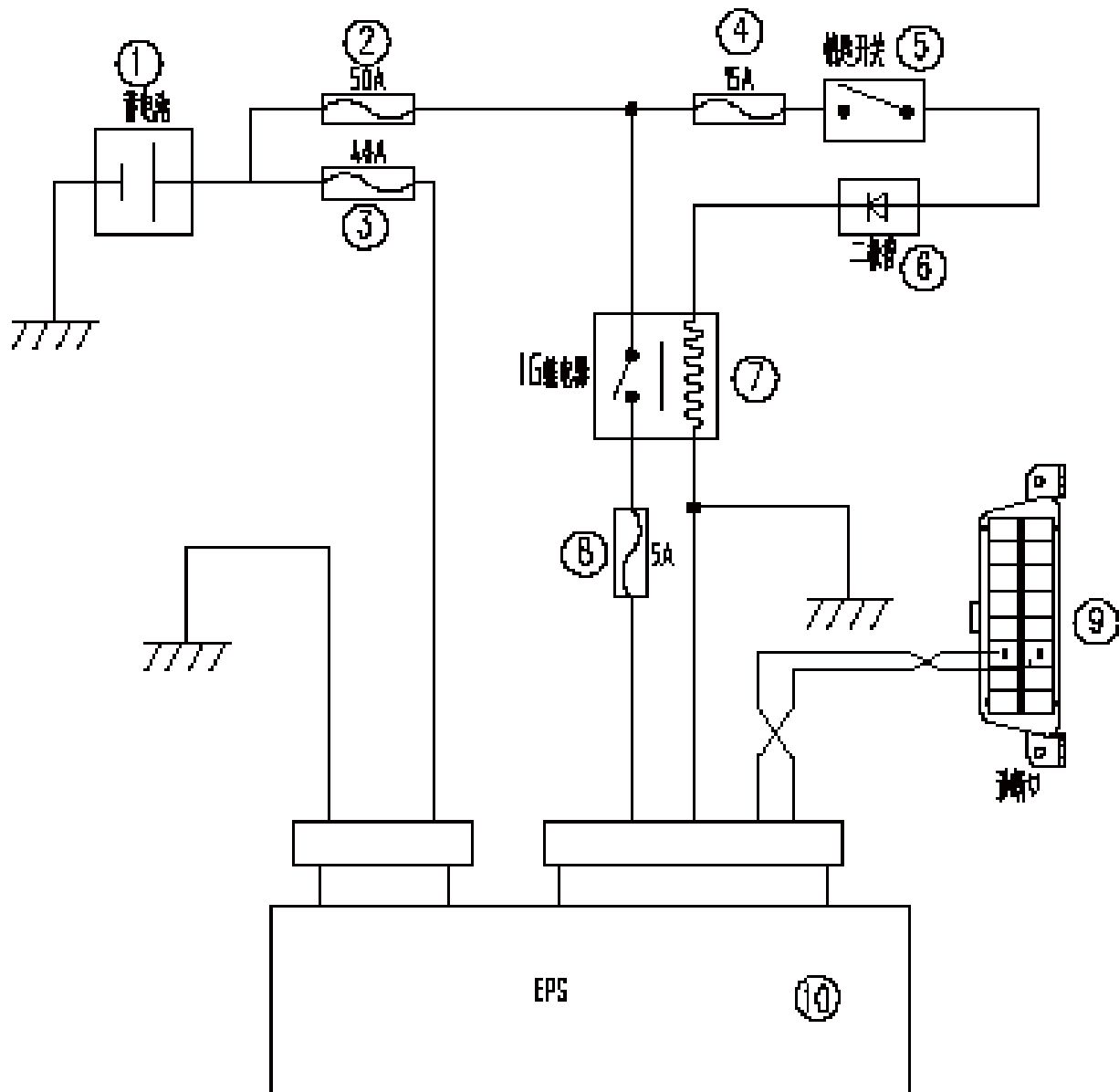

1. Battery

2. Fuse 50A

3. Fuse 40A

4. Fuse 15A

5. Key switch

6. Diode

7. IG relay

8. Fuse 5A

9. OBD

10. EPS

EPS TROUBLE REMOVAL

→ TROUBLE SHOOTING

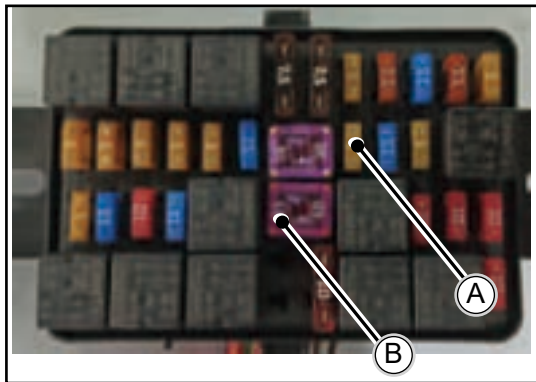

If the EPS is not working, first check whether the EPS fault light on the meter is on. If the fault light is not on, check whether the 5A fuse **【A】** and 50A fuse **【B】** in the fuse box are blown, and check whether there is speed on the meter **【C】** display, if there is no speed display, EPS will not work, and the EPS fault light on the meter will not light up.

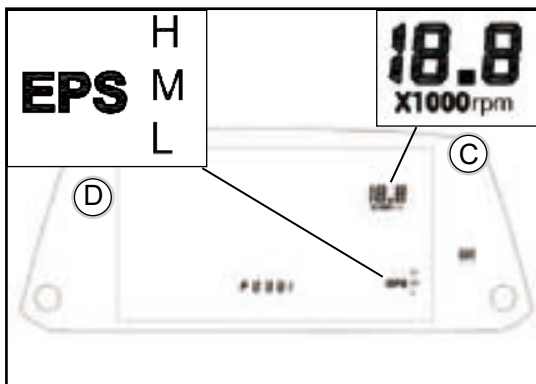

- ◆ The position of EPS gear in the meter, EPS is divided into three gears: H/M/L **【D】**, the default is M gear, when in four wheel drive locking mode, it will immediately switch to H gear; M gear and L gear are adjusted on the Segway Powersports APP (only vehicles with TBOX can be adjusted)

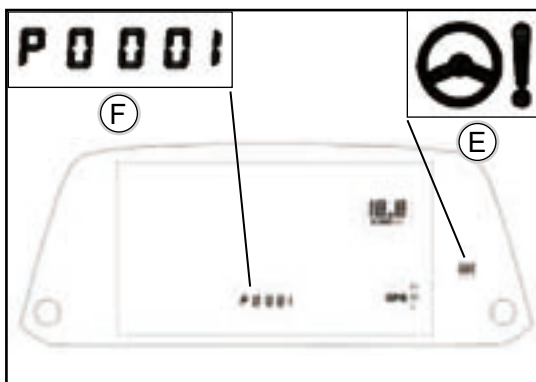

If the EPS fault light on the meter is on, it means that the EPS is malfunctioning.

- ◆ EPS fault light **【E】** and fault code **【F】** in the indicator
- ◆ The location is shown left.

The EPS fault codes displayed in the instrument are listed below:

NO.	Fault description	Fault grade	With or without power	Recoverability within the current ignition cycle	Fault code	Fault light
1	Torque midpoint not written	3	Yes	Recoverable after fault elimination	E0001	on
2	Rotor angle midpoint not written	1	No	Recoverable after fault elimination	E0002	off
3	Storage read and write failure	1	Yes	Yes	E0003	on
4	The main torque sensor is disconnected	1	Vehicle speed is set to 30	No	E0004	off
5	The main torque sensor output is abnormal	1	Vehicle speed is set to 30	No	E0005	off
6	The secondary torque sensor is disconnected	1	Vehicle speed is set to 30	No	E0006	off
7	Secondary torque sensor output failure	1	Vehicle speed is set to 30	No	E0007	off
8	Excessive difference between primary and secondary torque	1	Vehicle speed is set to 30	No	E0008	off
9	Abnormal primary and secondary torque	1	No	No	E0009	on
10	Motor offer no assistant power	1	No	No	E0010	on
11	overcurrent	1	No	No	E0011	on
12	Abnormal current	1	No	No	E0012	on
13	CAN communication abnormal	2	Vehicle speed is set to 30, cancel aligning and damping	Recoverable after CAN normalization	E0013	on
14	Rotor angle sensor disconnected	1	No	No	E0015	on
15	Power module failure	1	No	No	E0016	on
16	A phase current abnormal	1	No	No	E0017	on
17	C phase current abnormal	1	No	No	E0018	on

DISPLAY AND HUMAN-COMPUTER INTERACTION

DASHBOARD

The dashboard displays key information to the user.





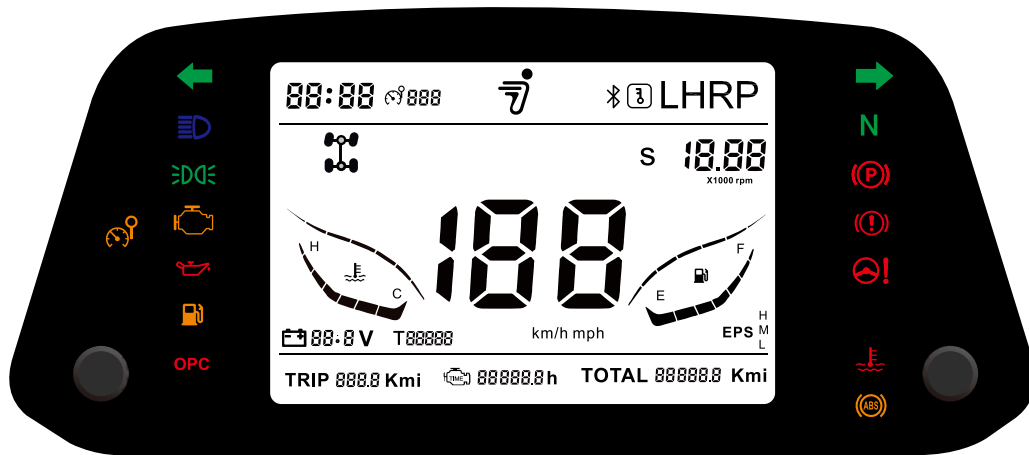

See the next page for display functions and instructions









⚠ WARNING

Using a high-pressure water gun may damage the dashboard. You should use your hands or hoses to clean the vehicle with neutral soap. Do not use alcohol or corrosive cleaning agents, such as insect repellents, to clean the dashboard.



DASHBOARD INDICATOR LIGHT DESCRIPTION

Item	Icon	Function description	Fault phenomenon	Analysis of cause and trouble shooting
Left turning		This indicator will be on when turn on the left turning light	This indicator not on when the left turning light is on	Check whether PIN 29 has high level input, if yes, replace the meter, if not, check the relevant electric line
High beam		This indicator will be on when turn on the high beam	This indicator not on when high beam is on	Check whether PIN 30 has high level input, if yes, replace the meter, if not, check the relevant electric line
Position indicator		This indicator will be on when front light, tail light ,license plate light, dashboard light are on	This indicator not on when position light is on	Check whether PIN31 has high level input, if yes, replace the meter, if not, check the relevant electric line
Fault indicator		When the fault indicator light is on, it indicates that the following systems have faults: Emission control system; Engine electronic control system;	—	—
Oil pressure		This indicator will be on if the oil pressure is too low	—	—
Low Fuel		This indicator will be on if the fuel level in the tank is too low	The indicator not on when fuel level is lower than the last line	Check fuel level sensor or replace the dashboard
Off cushion alarm	OPC	This indicator will be on if the vehicle not in parking brake when driver is off cushion, meanwhile the buzzer will alarm	Off cushion and apply the parking switch, buzzer not beep light not on	Check the parking switch and the off cushion switch

Right turning light indicator		This indicator will be on when right turning light is on	This indicator not on when right turning light is on	Check if PIN12 has high level input, if so ,replace the meter, if No. check the related wiring
'N' gear indicator		Shift lever in 'N' gear	Shift lever in 'N' gear and the indicator not on	Check if PIN11 has low level input, if so, replace the meter, if No, check the related wiring, whether the wiring harness is loose or broken
Parking indicator		The indicator will be on when the parking switch is applied	The indicator not on when the parking switch is applied	Check if PIN10 has low level input, if so, replace the meter, if No, check the related wiring, whether the wiring harness is loose or broken
Brake system alarming		<ul style="list-style-type: none"> • Brake fluid level too low • Brake system have fault 	—	—
Electric steering system alarming		EPS have fault (optional)	—	—
"ABS" Alarm light		<p>The following system have fault</p> <ul style="list-style-type: none"> •ABS ; • Brake auxiliary system (optional) 	—	Check the level of the coolant and the leakage of the coolant
Speed limit alarm Indicator		In the speed limit mode, when the driving speed is greater than the set speed limit, the speed limit indicator (yellow) flashes and the buzzer alarms at the same time, and the alarm is lifted when the driving speed is ≤ 100 km/h.	—	—
Coolant high temperature indicator		This indicator show the high temperature of the engine coolant. stop the engine immediately when the indicator on	—	—



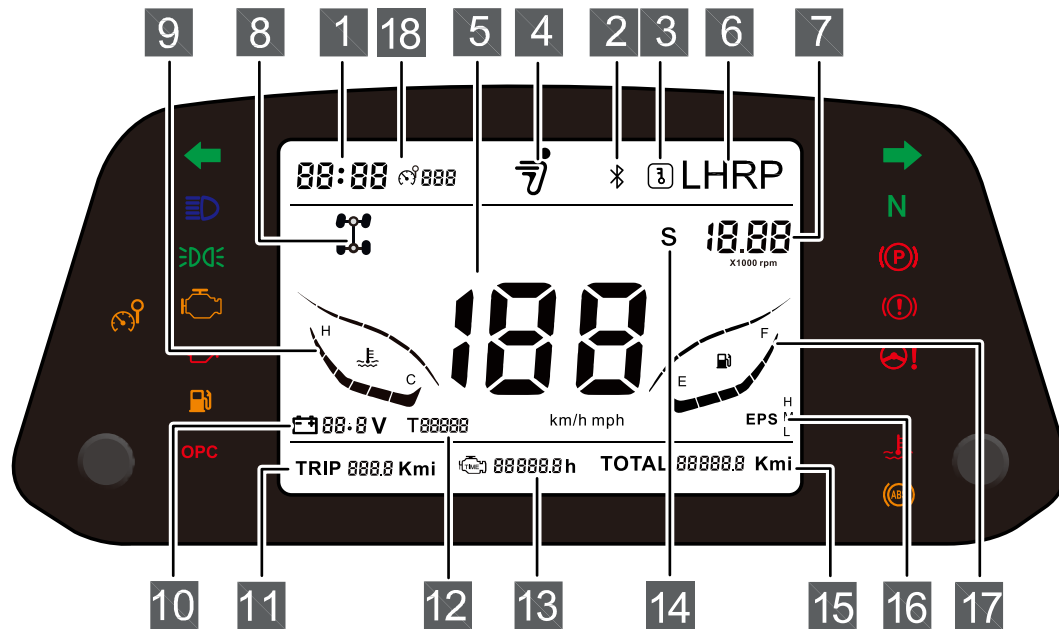



INSTRUMENT INFORMATION DISPLAY



NO.	Area	function description	Fault	Toubleshooting
1	Time display	Showing current time	—	—
2	Bluetooth	When mobile Bluetooth and T-BOX are connected successfully and the light will be on.	Power on remotely by Bluetooth, this icon not lights up	Check dashboard CAN-H,CAN-L wire harness, if not solve it , replace TBOX if still no replace dashboard
3	Power on remotely	When power on the ATV, the APP in the mobile phone, Click the remote power on button and the light will be on. (The premise is that T-BOX networking is successful)	Power on remotely by APP, this icon not lights up	Check dashboard CAN-H,CAN-L wire harness, if not solve it, replace TBOX if still not,replace dashboard
4	Company logo	This icon light up when vehicle on power	—	—
5	Vehicle speed display	Display actual vehicle speed	Display wrong speed or no display	Check PIN4 loose check vehicle speed sensor, replace meter or speed sensor

ELECTRICAL SYSTEM

SEGWAY AT5

6	Gear display	Display the correctly gear L -Low speed H -High speed R -Reverse P -Parking	No gear display	Check gear position sensor and related electric line
7	RPM	Display actual engine speed	No engine speed display	Check CNA-H,CAN-L Wire harness, check ECU, and crankshaft position
8	Four-wheel drive full differential lock	 2 x 4 patterns  4 x 4 patterns  4x4 locking mode  2 x 4 patterns(With differential)  4 x 4 patterns(With differential)  4x4 locking mode(With differential)	—	—
9	Coolant temperature indicator	Displays current coolant temperature H -High temperature C -Low temperature	No coolant temperature display	Check CNA-H,CAN-L wire harness check ECU
10	Accumulator voltage	Displays the current voltage of the vehicle battery	—	—
11	Subtotal mileage	Single trip mileage	—	—
12	Fault code display	Fault code will display when ECU、EPS、 T-BOX Fails	—	—
13	Engine operation time	Display engine operation time	Display wrong engine operation time	Check if display engine operation time ,if yes, replace meter, if no ,check as the procedure of inspection engine speed

14	Mode display	When the vehicle is in sport mode, "S" lights up at this time		
15	Total mileage	Displays the total mileage accumulated by the vehicle	—	—
16	EPS On	EPS mode was set in the APP and the preferred mode of the rider was selected: M -Normal mode, power normal H -Comfort mode, power light L -Motion mode, booster weight	EPS model no display	Check CNA-H, CAN-L Wire harness Check EPS Check TBOX
17	Fuel meter	Displays the current amount of fuel	No display of the fuel mass	Check CNA-H, CAN-L Wire harness Check fuel level sensor Check TBOX
18	Speed limit setting icon	The instrument displays the speed limit icon when the speed limit is on, but not when it is off		

Dashboard button function introduction

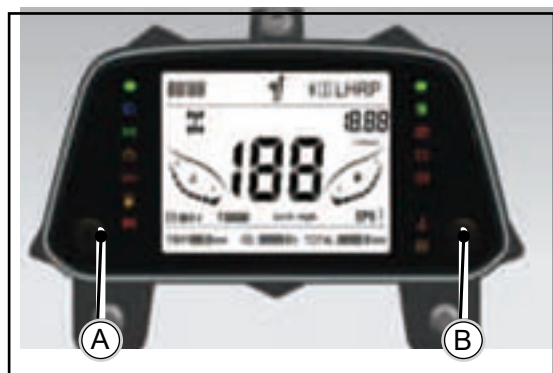

Function	A button	B button	Display
Brightness adjustment	Short press		Adjust backlight brightness (default: brightest)
Subtotal Clear	Long press		Zero subtotal mileage
EPS gear switching		Short press	EPS level shift signal sent
Metric or imperial units		Long press	Metric or imperial units switching
Clock settings	Long press	Long press	Clock hour flashing
	Short press		Hour+1
		Long press	Hour continuous+1
	Short press		Clock minute flashing
		Short press	Minute+1
		Long press	Minute continuous +1

- ◆ Zeroing total mileage: under power off condition, press and hold button A and B at the same time, then turn on the key and power on, the interface "CCC--" will appear, adjust by button: short press left button to shift, short press right button to adjust the current position. After adjusting "CCC--" to 226, zero the mileage, the condition of zeroing the mileage is within 200KM and the number of times of zeroing the mileage is less than 3 times.

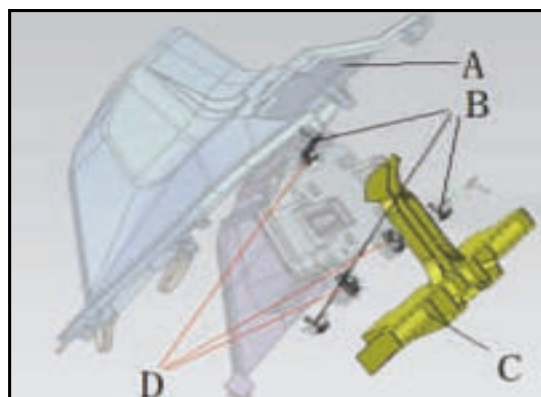

DASHBOARD DISASSEMBLY AND ASSEMBLY

⚠ CAUTION

Before removing the meter, be sure to power off the vehicle.

- ◆ Unplug the connector on the back of the dashboard
- ◆ Remove the plastic parts 【A】 first
- ◆ Remove the three bolts 【B】
- ◆ Remove the plastic parts 【C】
- ◆ Remove the three bolts 【D】
- ◆ Remove the dashboard and replace it with a new one

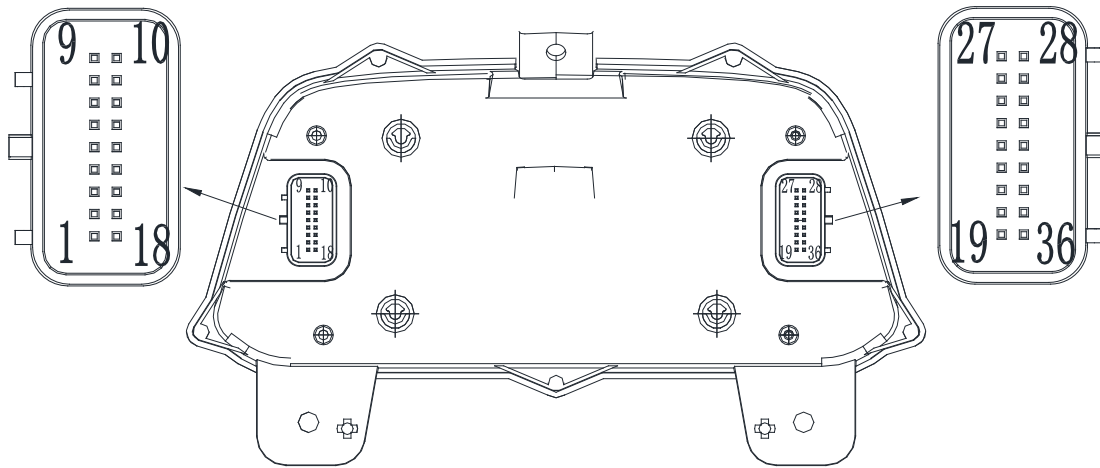

pin	Description	note	pin	Description	note
1	CAN-L	—	19	Brake failure alarm	Low level
2	CAN-H	—	20	4WD signal	—
3	Sensor power supply	—	21	—	—
4	Vehicle speed	Pulse signal	22	Seat cushion switch	Low level
5	Power ground	—	23	Oil pressure	Low level
6	—	—	24	"R" gear	Low level
7	—	—	25	"P" gear	Low level
8	—	—	26	"H" gear	Low level
9	—	—	27	"L" gear	Low level
10	Parking signal	Low level	28	—	—
11	N"N" gear	Low level	29	Left turn signal	High level
12	Right turn signal	High level	30	High beam	High level
13	ABS light (reserved)	Low level (reserved)	31	Position light	High level
14	B+	—	32	—	—
15	Power ground	—	33	—	—
16	—	—	34	Power ground	—
17	Key power	—	35	Buzzer output	—
18	—	—	36	—	—

T-BOX

⚠ CAUTION

If multiple vehicles are repaired at the same time, do not exchange and install the T-BOX

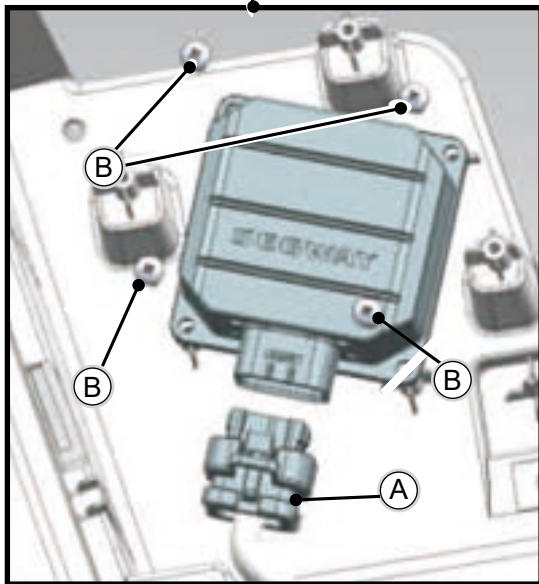
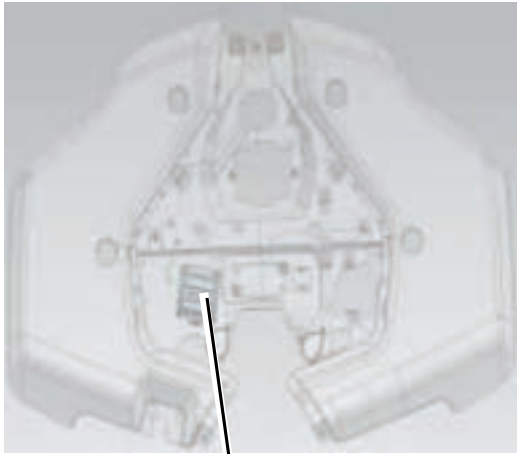

- ◆ Power off the whole vehicle first and remove the front shelf assembly
- ◆ Pull out the connector 【A】
- ◆ Remove the four bolts 【B】

T-BOX FAULT CODE DISPLAY AREA

T0001	GPS module failure
T0002	4G module failure
T0003	Bluetooth module failure
T0004	Sensor failure
T0005	Power CAN failure
T0006	Body CAN failure

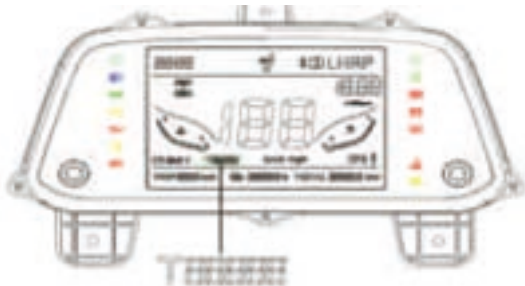

Failure phenomenon and failure reason		
NO.	Trouble	Solution
1	Fault code T0001	Replace T-BOX
2	Fault code T0002	Replace T-BOX
3	Fault code T0003	Replace T-BOX
4	Fault code T0004	Replace T-BOX
5	Fault code T0005	Check PIN9 and PIN14 have signal
6	Fault code T0006	Check PIN4 and PIN5 have
7	APP can not power on remote	Check signal circuit replace T-BOX

T-BOX INTERFACE DEFINITION

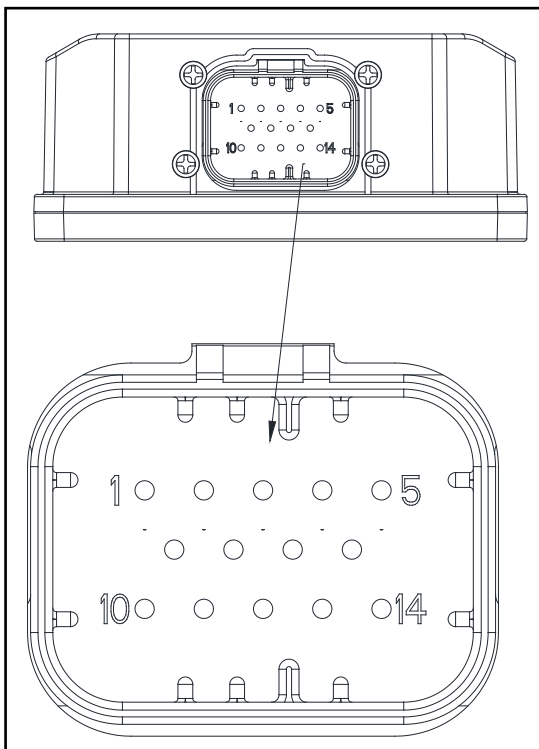

Pin	Description	Note
1	GND	
2	MIgnition	Check if the mechanical key to power on or not
3	NG	—
4	CAN1+	Body CAN+
5	CAN1-	Body CAN-
6	REALY_OUT	Power on remotely relay interface
7	ACC	
8	CAN3+(Reserve)	
9	CAN2+	Engine CAN+
10	B+	Battery power
11	OIL+	
12	OIL-	
13	CAN3-(Reserve)	
14	CAN2-	Engine CAN-

SWITCH

POWER LOCK

⚠ CAUTION

When the indicator does not display after the key is turned on, check the circuit failure (see page xx), and replace the power lock after confirming that the power lock is broken

CLR FUNC	R	B	Key can be taken out
ON	●	●	NO
OFF			YES
LOCK			YES

→ Check Power lock

After unplugging the connector, turn the multimeter to the conduction position. When the key is turned to the OFF position, the two wires should not be able to conduct; when the key is turned to the ON position, the two wires should be able to conduct;

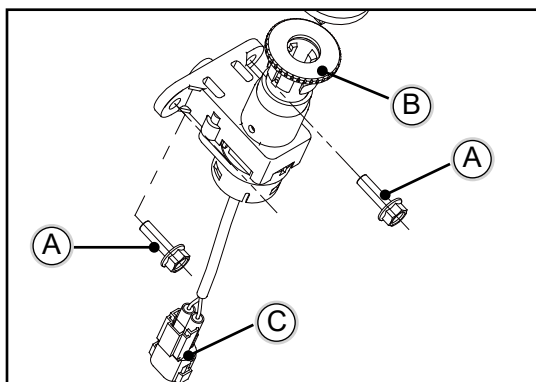

When you need to replace the power lock, first remove the seat cushion and fuel tank guard (see "vehicle body and frame") .

- 【A】 M6 bolt
- 【B】 power lock
- 【C】 connector

- ◆ Remove the two M6 bolts
- ◆ Unplug the connector ,remove the power lock

NOTICE

In the normal state, the ON gear is in the forward direction, turning 45 degrees counterclockwise is the OFF gear, pressing down the key while rotating 90 degrees counterclockwise is the LOCK gear

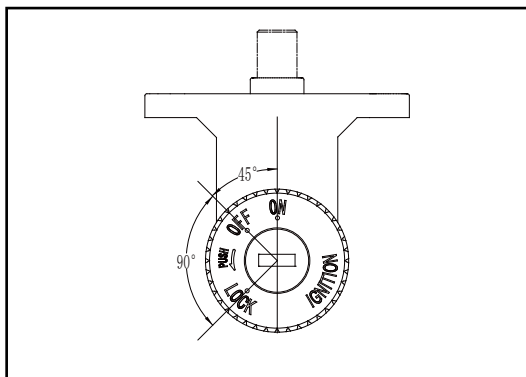

In the ON gear, the entire vehicle circuit is connected and the key cannot be removed;

In the OFF gear, the entire vehicle circuit is disconnected and the key can be removed;

In the LOCK gear, the front of the vehicle is in a locked state (see "vehicle body and frame") and the key can be removed;

LEFT HANDLEBAR SWITCH

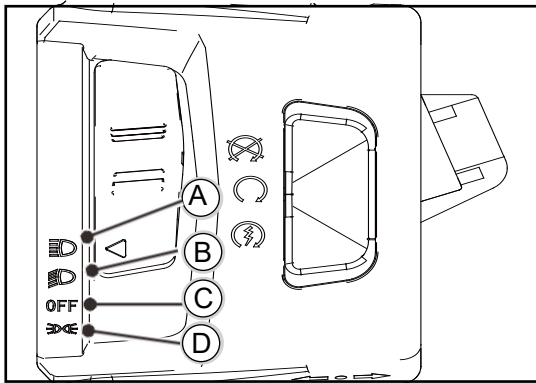

⚠ CAUTION

The switch is valid only when the power lock is in the ON position

- 【A】 Turn on high beam
- 【B】 Turn on lower beam
- 【C】 Turn off light
- 【D】 Turn on position light

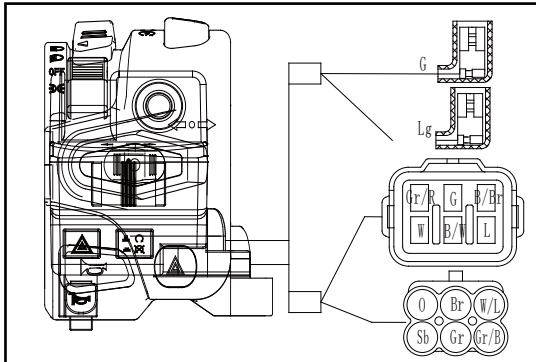

⚠ CAUTION

Since the switch is an integral part, any damage to the switch requires replacement of the entire switch

	CLR	B/Br	Br	L	B/Br	W
FUNC		<input type="checkbox"/>	<input type="checkbox"/>			
	OFF					
		<input type="checkbox"/>	<input type="checkbox"/>	<input type="checkbox"/>		
		<input type="checkbox"/>			<input type="checkbox"/>	

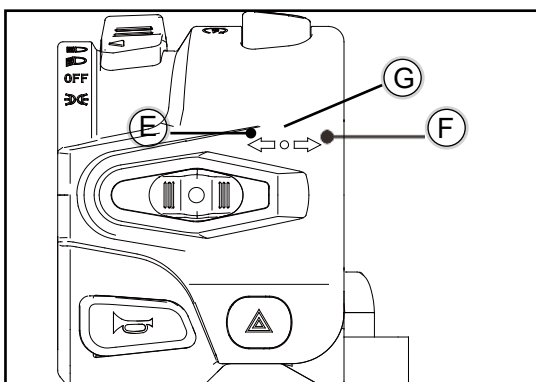

- 【E】 Turn on left turning light
- 【G】 Turn off the turning light
- 【F】 Turn on the right turning light

➔ Check if the turning light switch work normally

When the switch is turned to the left steering position, gray and orange can be connected, while gray and light blue cannot be connected ; when the switch is turned to the right steering position, gray and light blue can be connected, and gray and orange cannot be connected;

	CLR	0	Gr	Sb
FUNC				
		<input type="checkbox"/>	<input type="checkbox"/>	
			<input type="checkbox"/>	<input type="checkbox"/>

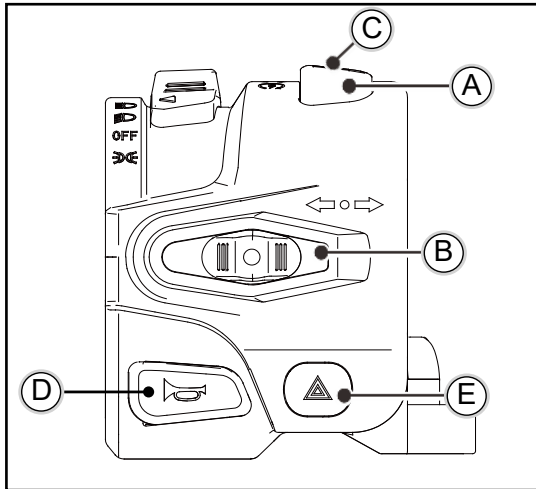

- 【A】 Start button
- 【B】 Left and right turn signal switch
- 【C】 Flameout switch

When the engine is running, press the flameout switch button to stop the engine;

when the engine is stopped, first pop up the flameout switch button, and then press the start button to start the engine;

When the function fails, check the related circuit first;

when all circuits are checked to be OK, test the internal circuitry of the flameout switch.

⚠ CAUTION

The engine can only be started by pressing the start button when the flameout switch is in the pop-up position

	CLR	B/W	/	W/L
FUNC				

	CLR	Gr/R	/
FUNC			

→ Test flameout switch for damage

When the flameout switch is popped up, black-white and white-blue should be able to conduct, and when the start button is pressed at this time, gray-red, black-white, white-blue should be able to conduct;

when the flameout switch is pressed, black-white and white-blue cannot be conducted, and when the start button is pressed at this time, the gray-red, black-white, white-blue all cannot be conducted;

	CLR	Lg	B/Br
FUNC			

【D】 Horn Switch

→ Test horn switch for damage

When the key is in the ON position, it should make a sound when pressing the horn switch;

when the horn cannot make a sound, first check relevant circuit;

when there is no problem with the circuit, test the internal circuit of the horn switch;

when pressing the horn switch, light-green and black-brown should be able to conduct;

	CLR	O	Gr	Sb
FUNC				
DOWN				
UP				

【E】 Emergency switch

When the emergency switch is pressed, the four front and rear turning lights flash at the same time; when the emergency switch is pressed, if a single turning light does not light up, check the relevant fuse or the lamp itself.;

→ Check emergency switch

When the emergency switch is pressed, if the four front and rear turning lights do not flash, the internal circuit of the emergency switch can be tested;

when the emergency switch bounces, the orange, gray, and light blue should not be conductive;

when the emergency switch is pressed, orange, gray and light blue should be able to conduct;

ASSEMBLY AND DISASSEMBLY OF LEFT HANDLEBAR SWITCH

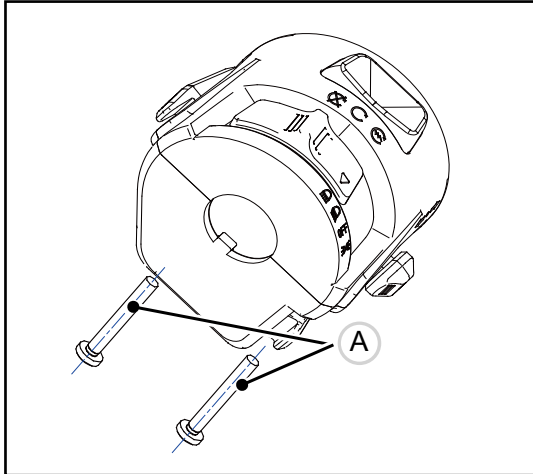

【A】 Fastening bolts

- ◆ Remove the two fastening bolts by tool;
- ◆ Remove the switch from the handlebar;
- ◆ When installing a new switch, take care to snap the lower cover's limit into the handlebar limit slot, then tighten the two fastening bolts with a tool;

【B】 limit position

- ◆ Rotate the switch around the handlebar tube after installation to confirm whether it is installed in place, and it should not be able to rotate after installation.

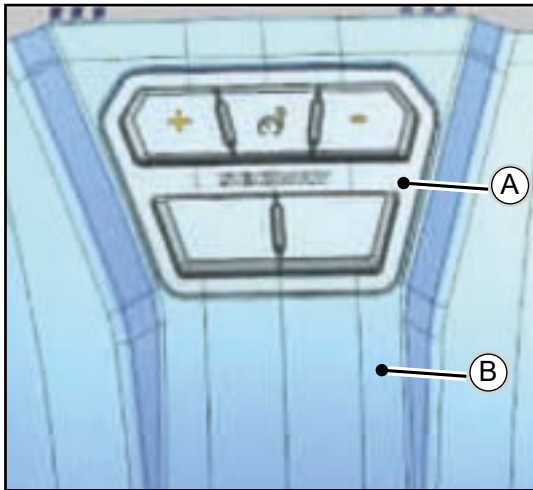

SPEED SWITCH

Detection and replacement:

ABS switch damaged or electrical signal abnormal, identify the fault point;

Confirm that the problem is a damaged or malfunctioning ABS switch, and replace it according to the following method.

Open the small cover of the front storage box with the key

【A】 ABS speed control switch

【B】 Storage box small cover

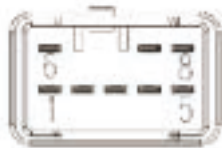

Pin No.	Symbol	Label	Color	Notes
1	⊕	—		
2	⊕	—		
3	-	速度传感器	蓝色	
4	⊕	速度传感器	蓝色	
5	-	速度传感器	蓝色	
6	⊕	—		
7	⊕	速度传感器		
8	⊕	速度传感器-12V		

- ◆ Remove the small cover of the storage box,
- ◆ Use tools to release several buckles between the ABS switch and the small cover of the storage box
- ◆ Unplug the connector
- ◆ Remove the ABS switch

⚠ CAUTION

When replacing the ABS switch, the wiring harness should first pass through the small hole under the storage box cover, assemble the wiring harness plug with the ABS switch, and then snap it into the storage box cover.

RIGHT HANDLEBAR SWITCH

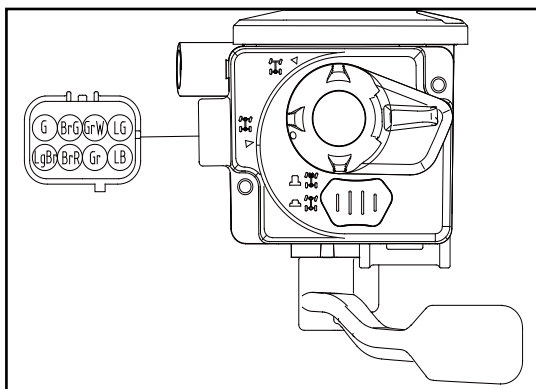
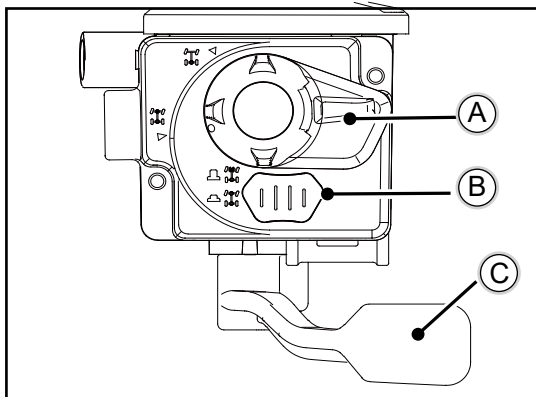

FUNC	KNOB	Butt	LB	LG	BrR	BrG	Gr	GrW	LgBr	G
2WD	2WD	4WD	●	●				●		
4WD	4WD	4WD	●	●	●	●				
4WD	4WD	LOCK			●	●	●	●	●	●

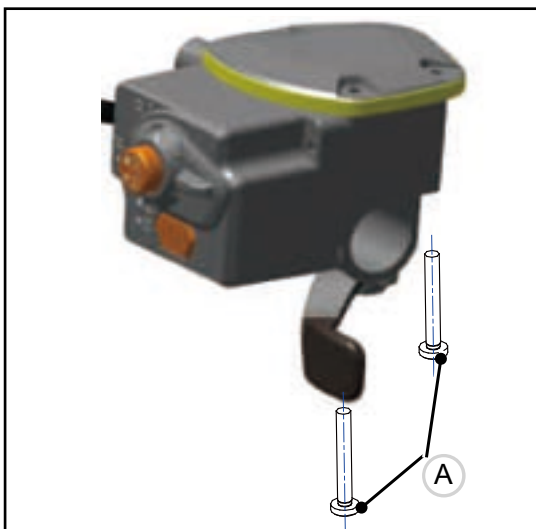

CAUTION

The switch is valid only when the power lock is in the ON position

- 【A】 2-4WD switch
- 【B】 4WD lock switch
- 【C】 Accelerator

Test 2-4WD switch for damage

When the knob switch is turned to the 2WD position, the switch is in 2WD, at which time brown-red and blue-green and blue-black can conduct;

When the knob switch is turned to the 4WD position, the switch is in 4WD state, at this time the brown-red and brown-green, blue-green and blue-black can conduct;

When the knob switch is rotated to the 4WD position, after popping up the 4WD lock switch, at this time the gray and gray-white, brown-red and brown-green, light green-brown and green can lead through respectively.

ASSEMBLY AND DISASSEMBLY OF RIGHT HANDLEBAR SWITCH

- 【A】 Fastening bolts
- ◆ Remove the two fastening bolts by tool;
- ◆ Remove the switch from the handlebar;
- ◆ When installing a new switch, tighten the two fastening bolts with a tool;
- ◆ Rotate the switch around the handlebar tube after installation to confirm whether it is installed in place, and it should not be able to rotate after installation.

WINCH ASSEMBLY

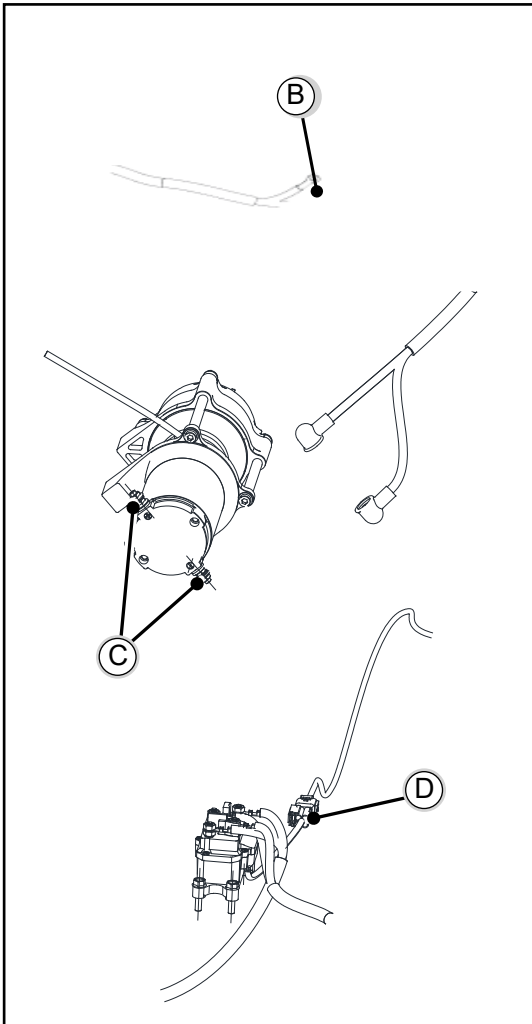
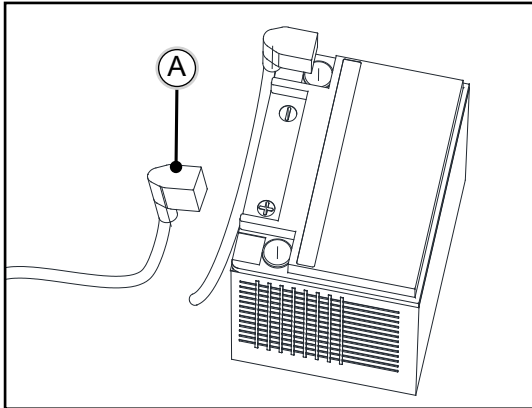

REMOVAL

⚠ CAUTION

When removing the winch, first power off the vehicle power

- ◆ Remove external related plastic parts
- ◆ First remove the battery positive electrode 【A】
- ◆ Remove the power cable of the winch 【B】
- ◆ Remove the winch motor cable nut 【C】
- ◆ Unplug the plug 【D】
- ◆ Cut off the cable tie along the cable

⚠ WARNING

Be sure to disconnect the battery before disassembling the winch assembly to avoid short circuit

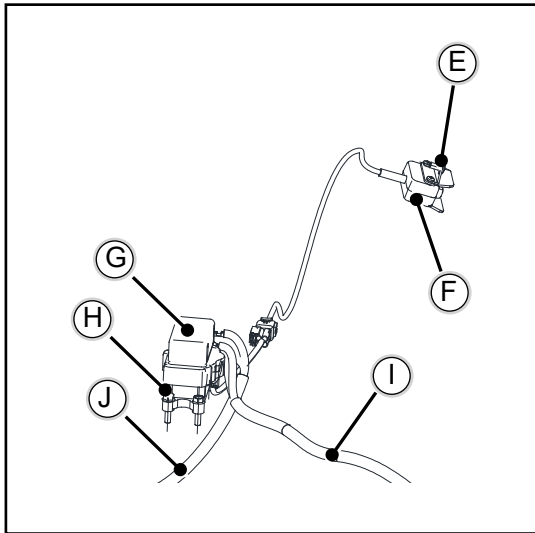

- ◆ Remove the bolt **【E】** , remove the winch switch **【F】**
- ◆ Remove the bolt **【H】** , then the winch power cord **【I】** , winch motor wire **【J】** and winch relay **【G】** can be removed together

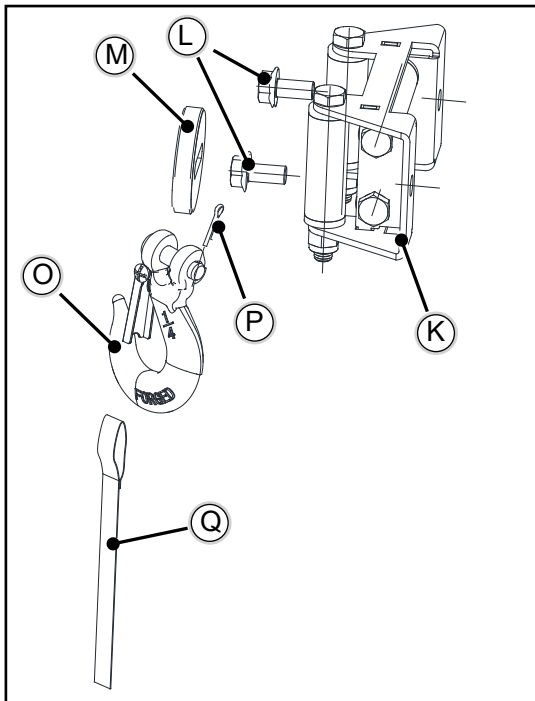

- ◆ After disassembling the bolt **【P】** and the wire rope **【R】** , you can remove the strap **【Q】** , hook **【O】** , and rubber pad **【M】**
- ◆ Remove the bolt **【L】** , and remove the guide wheel **【K】**

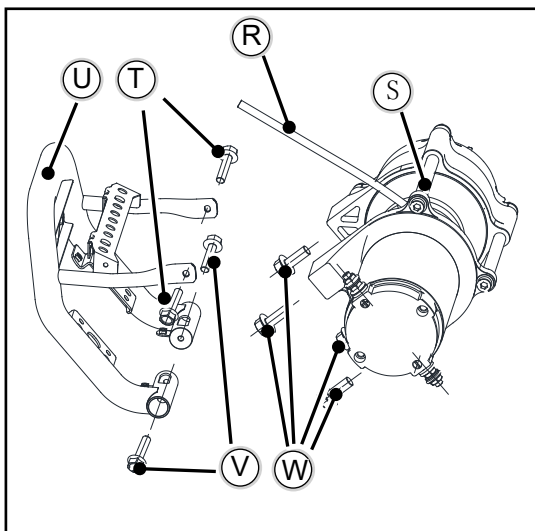

- ◆ First remove bolt **【T】** and bolt **【V】**
- ◆ Disassemble the bolt **【W】** , and remove the motor **【S】**

⚠ CAUTION

The winch work does not exceed 1min each time, and then works after an interval of 30S

- ◆ Rated working voltage DC12V
- ◆ Maximum working tension 2500LBS or 3000LBS
- ◆ The maximum working current ≤ 185 A, the maximum working current lasts for 1 min, and work after an interval of 30 seconds. Continue to work in this way
- ◆ The wire rope diameter is 4.8 and the wire rope length is 14.5

The color of the insulation pad of the winch motor terminal and the heat shrinkable tube of the cable is one-to-one correspondence

- 【A】 YELLOW
- 【B】 BLUE

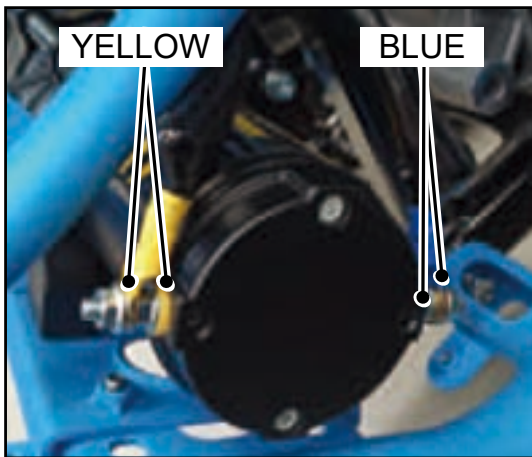

The color of the insulation pad of the winch motor terminal and the heat shrinkable tube of the cable is one-to-one correspondence

- 【C】 YELLOW
- 【D】 BLACK
- 【E】 RED
- 【F】 BLUE

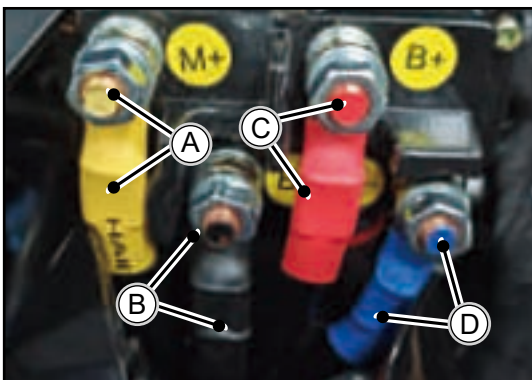

FUSE BOX



All fuses for the vehicle are in the fuse box

The fuse box is located under the front instrument mask.

Remove front panel repair cover

- ◆ After the front panel repair cover is removed, the fuse box located at the bottom can be seen.
- ◆ Move the clasp on the left and right sides of the fuse box cover to the outside. Loosen the clasp and open the fuse box.

⚠ CAUTION

- ◆ Do not use a fuse above the rated ampere value or replace it with anything else.
- ◆ Please use the same product. Never use wires for fuses, even temporary replacements are not allowed.
- ◆ Do not modify fuses or fuse boxes.

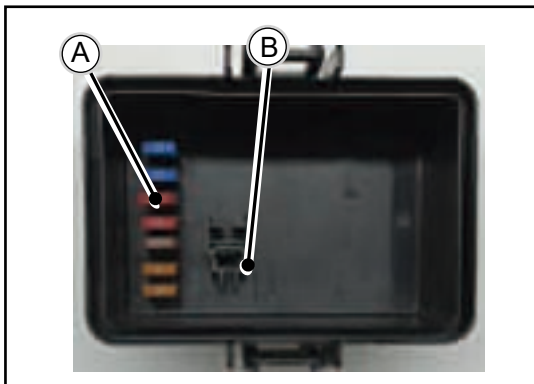
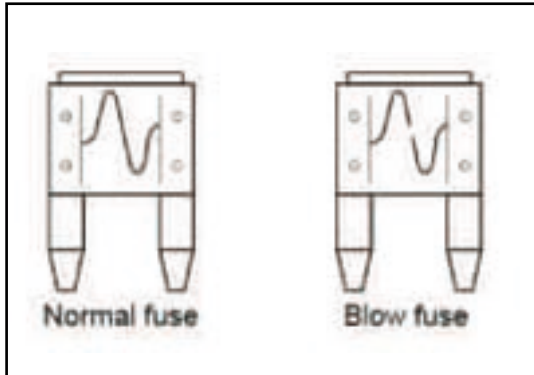

- ◆ If a chip fuse is broken, you can replace it with a spare fuse **【A】** of the same specification in the fuse box cover. Please use a fuse clamp **【B】** to replace the fuse.

FUEL BOX LABEL

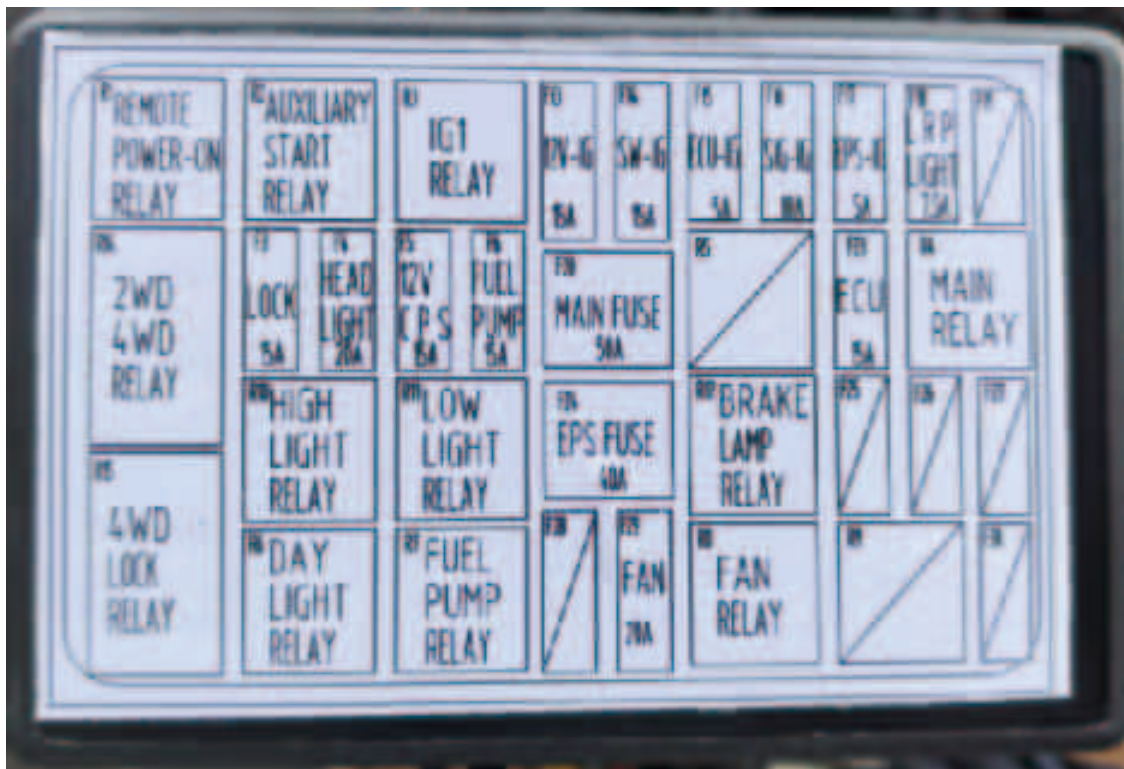

No.	Fuse/Relay	Power	No.	Fuse/Relay	Power
F3	Ignition lock	15A	R1	Remote power-on relay	12V 20A
F4	Head light	20A	R2	Auxiliary start relay	12V 20A
F5	ECU/Instrument/TBOX--CPS	15A	R3	IG relay	12V 20A
F6	Fuel pump	15A	R4	Main relay	12V 20A
F13	12V power socket	15A	R6	Daytime running light relay	12V 20A
F14	2-4WD/Turn signal/Horn	15A	R7	Fuel pump relay	12V 20A
F15	ECU-IG	5A	R8	Fan relay	12V 20A
F16	Speed sensor/Instrument/TBOX-IG	10A			
F17	EPS-IG	5A	R10	High beam relay	
F18	Trailer position light	7.5A	R11	Low beam replay	12V 20A
F20	Main fuse	50A	R12	Brake light relay	12V 20A
F23	Electronic fuel injection system\	15A			
F24	EPS	40A	R14	2-4WD relay-1	12V 20A
			R15	2-4WD relay-2	12V 20A
F29	Fan	20A			

WIRE HARNESS

⚠ CAUTION

1. The positive and negative connections of the battery cannot be reversed, which will cause the wires to burn out
2. All wiring screws must be tightened according to the required torque

Description of wire colors :

- ◆ R-red O-orange W-white B-black Y-yellow V-villet
- ◆ Sb-wathet blue G-green L-blue Br-brown Gr-gray P-pink Lg-low green

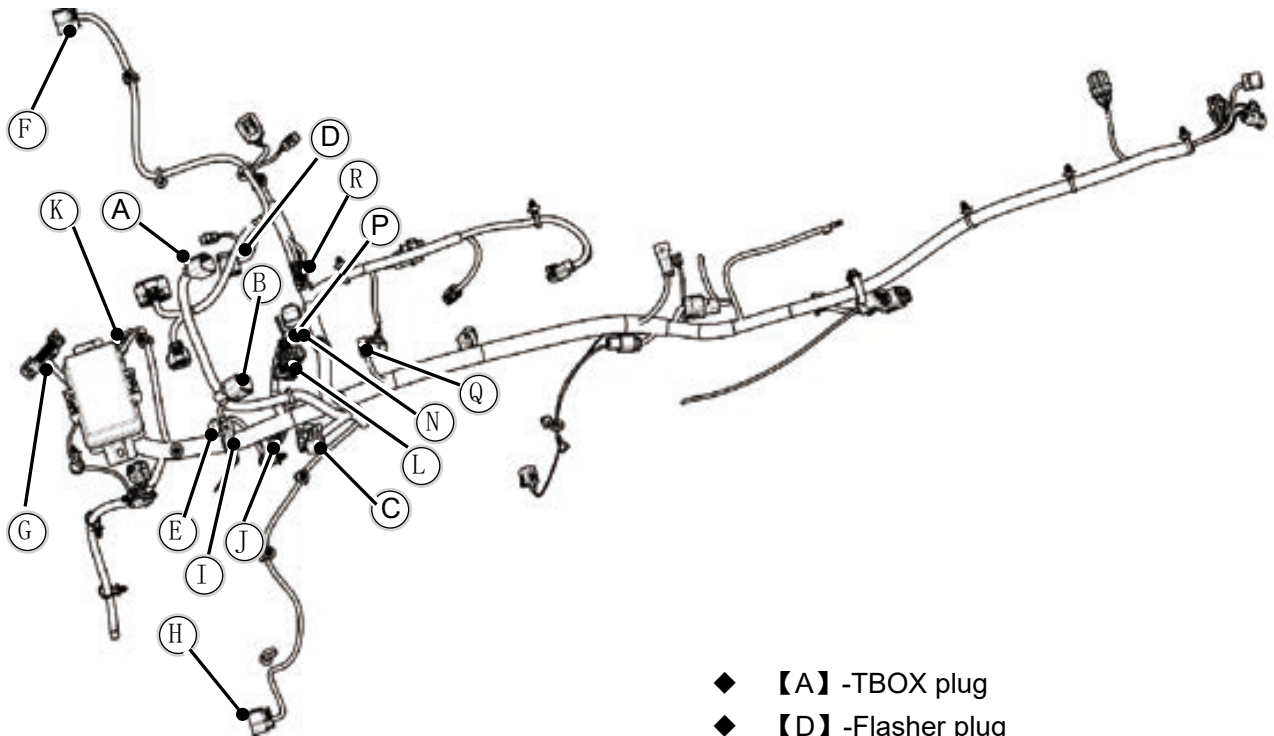

- ◆ 【A】 -TBOX plug
- ◆ 【D】 -Flasher plug
- ◆ 【E】 -Buzzer plug
- ◆ 【F】 -Right headlight plug
- ◆ 【G】 -OBD
- ◆ 【H】 -Left headlight plug
- ◆ 【I】 -EPS plug
- ◆ 【J】 -EPS plug
- ◆ 【K】 -Brake switch plug
- ◆ 【L】 -Left Handle plug
- ◆ 【M】 -Left Handle plug
- ◆ 【N】 -Right Handle plug
- ◆ 【P】 -Park switch plug
- ◆ 【O】 -Ignition lock plug
- ◆ 【R】 -Grounding

WIRE HARNESS ASSEMBLY

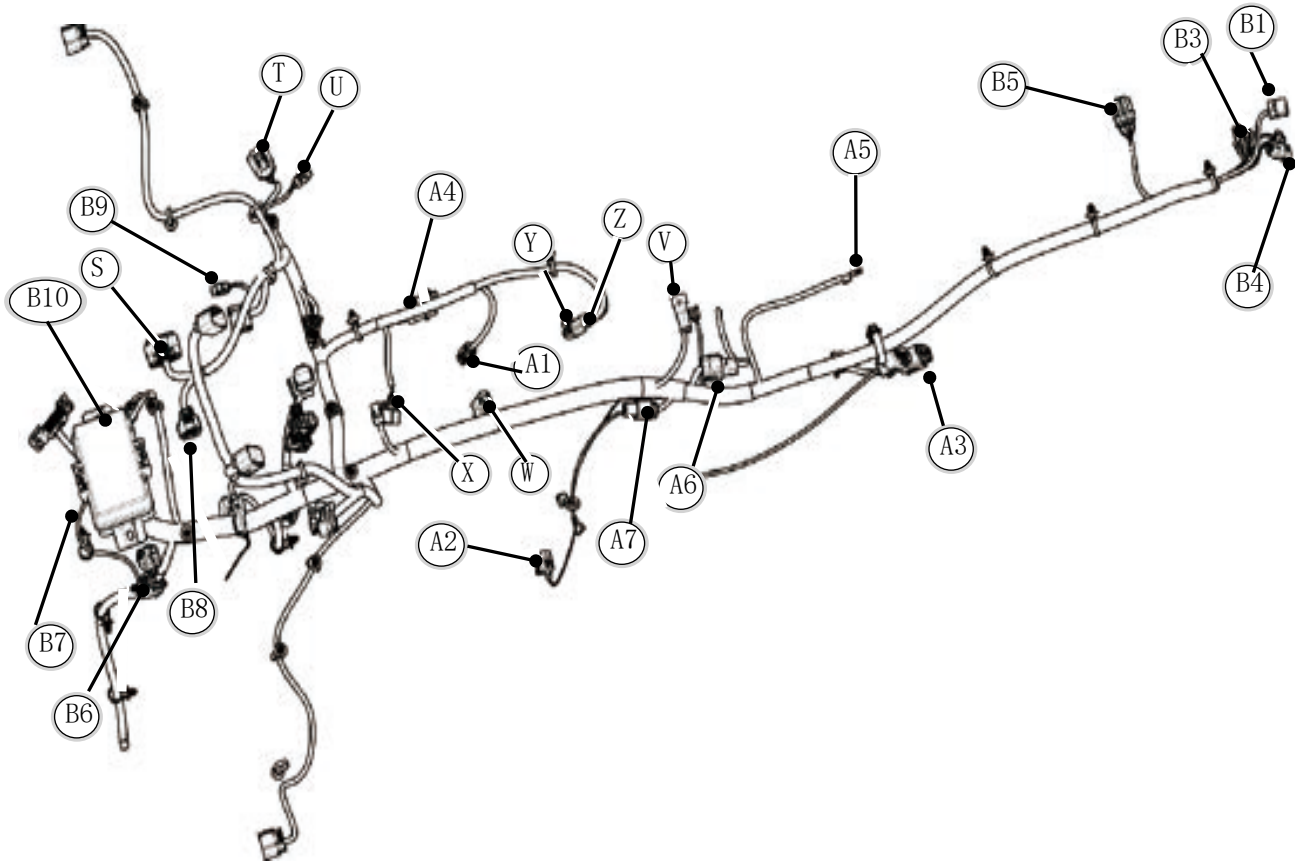

- ◆ 【S】 -ECU plug
- ◆ 【T】 -12V Power socket plug
- ◆ 【U】 -USB plug
- ◆ 【V】 -Leave seat alarm switch plug
- ◆ 【W】 -Fuel injector Plug
- ◆ 【X】 -Ignition coil plug
- ◆ 【Y】 -Intake pressure sensor plug
- ◆ 【Z】 -Idle motor plug
- ◆ 【A1】 -Coolant temperature sensor plug
- ◆ 【A2】 -Oil pressure alarm plug
- ◆ 【A3】 -Rectifier plug
- ◆ 【A4】 -Rear oxygen sensor plug
- ◆ 【A5】 -Grounding
- ◆ 【A6】 -Gear position sensor
- ◆ 【A7】 -CDI trigger
- ◆ 【B1】 -Rear taillight plug
- ◆ 【B3】 -Trailer power socket plug
- ◆ 【B4】 -License plate light plug
- ◆ 【B5】 -Fuel pump plug
- ◆ 【B6】 -Fan plug
- ◆ 【B7】 -Vehicle speed sensor&electromagnet plug
- ◆ 【B8】 -Fuel module plug
- ◆ 【B9】 -Main brake fluid level alarm plug
- ◆ 【B10】 -Fuse Box

WIRING DIAGRAM

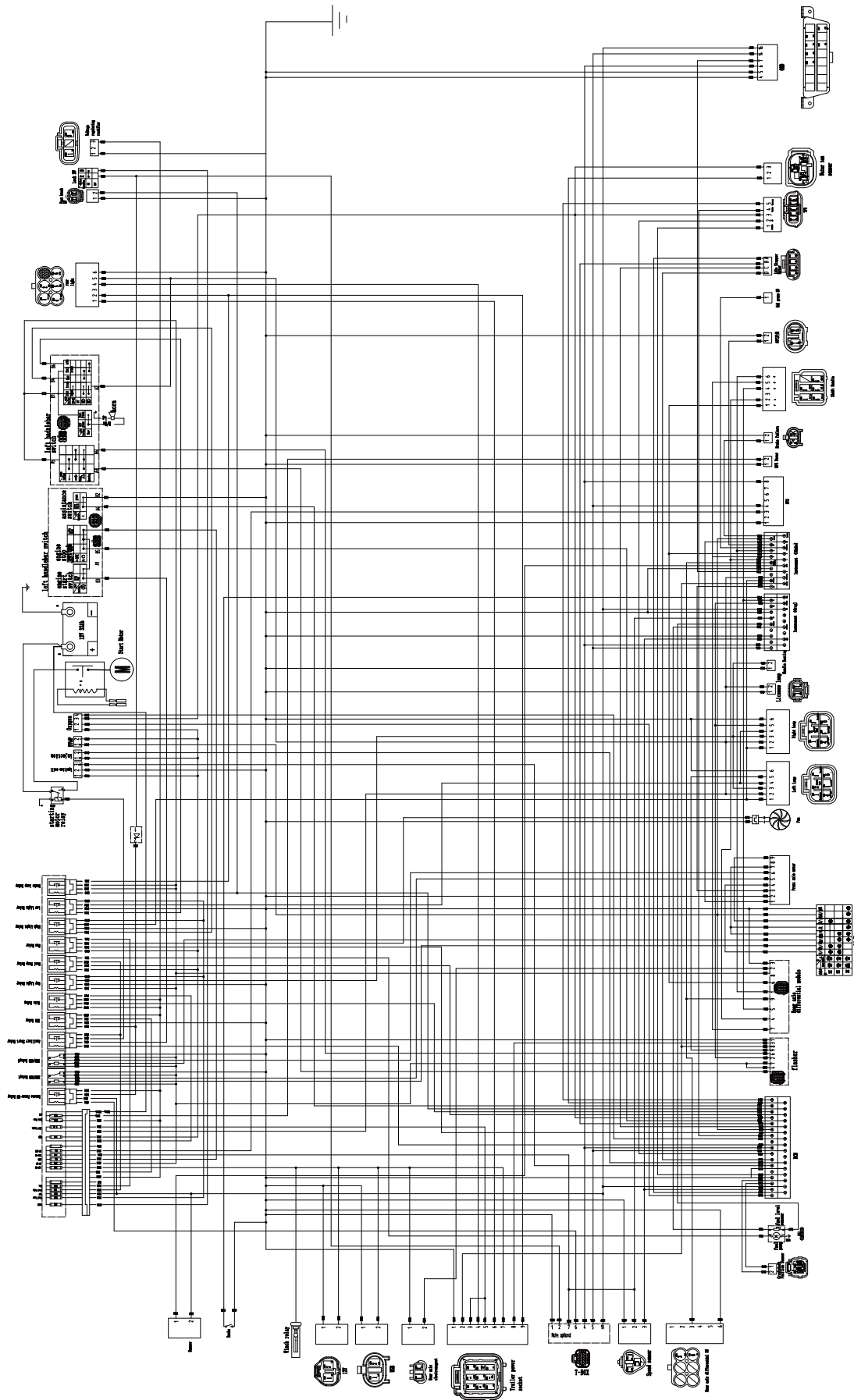

ABS SYSTEM (APPLICABLE TO ABS MODELS)

FUNCTION DESCRIPTION

The main function of ABS (Anti-lock Braking System) is to prevent the wheels from locking up during emergency braking, so as to maintain the stability and control of the vehicle. During emergency braking, ABS can automatically adjust the braking force of the brakes to keep the wheels in a rolling and sliding state, ensuring that the adhesion between the wheels and the ground is at its maximum value, thus improving braking effect and driving safety.

ABS SYSTEM PARTS

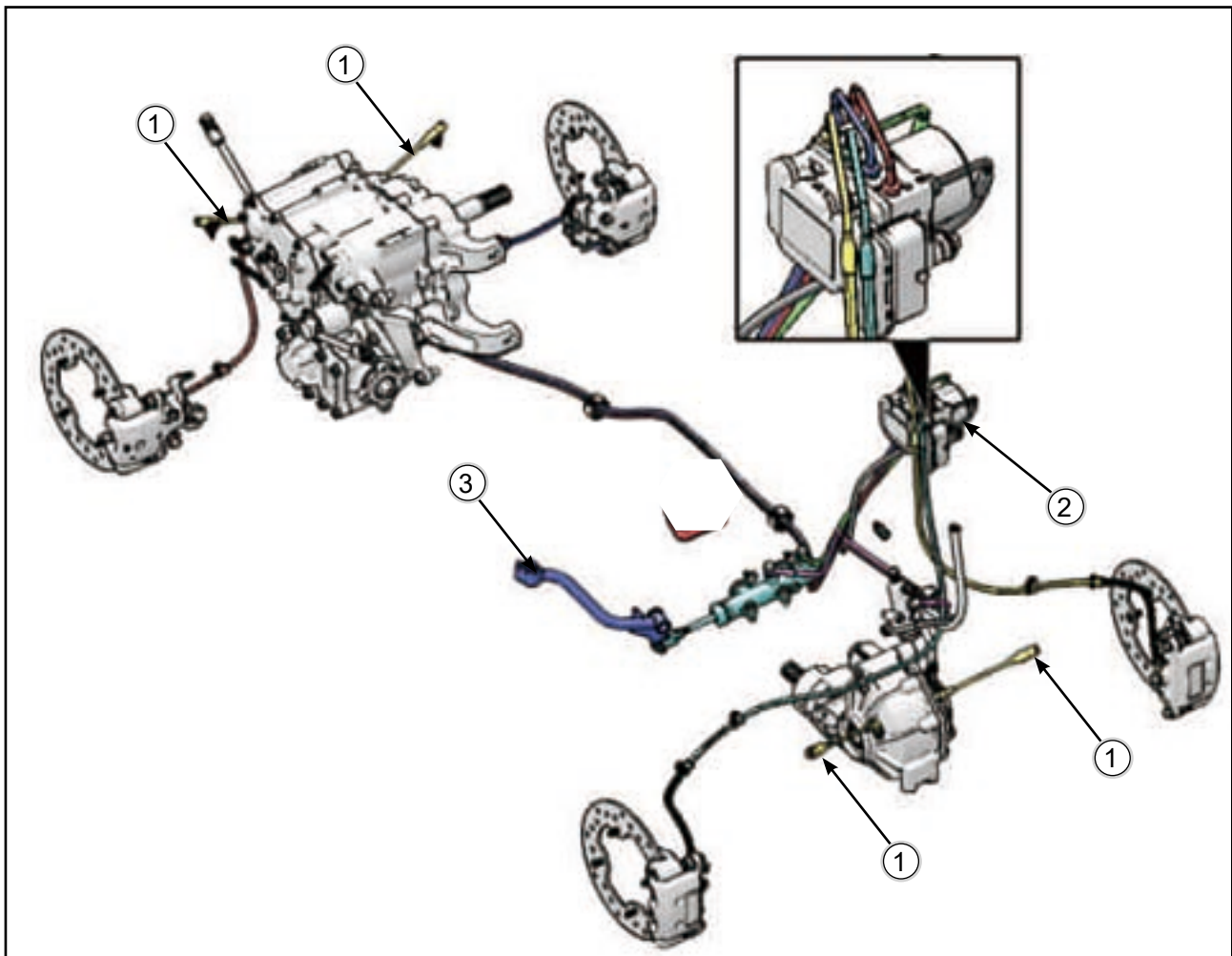

1、 ABS Sensor

2、 ABS Control Unit

3、 Brake Pedal

SEGWAY AT5

ABS SENSOR

The vehicle is equipped with four ABS sensors, two of which are located on the left and right sides of the front axle gearbox, and the other two are located on the left and right sides of the rear axle gearbox. The ABS sensors can be replaced if they fail.

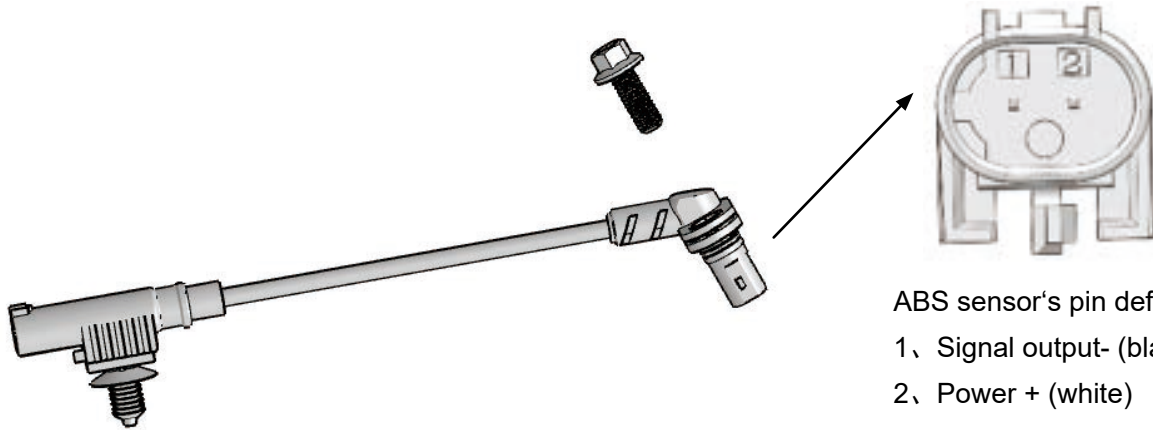

ABS sensor's pin definition:
 1、 Signal output- (black)
 2、 Power + (white)

ELECTRONIC CONTROL UNIT

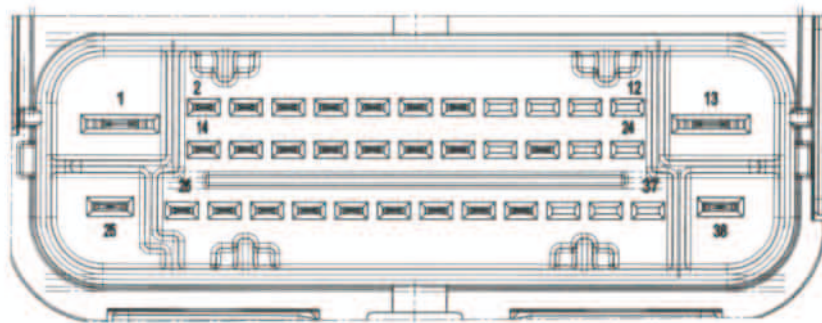

38-Pin Pin Definition			
1	Motor power supply	25	Valve relay sense power end (positive)
2	FR wheel speed signal output	26	High-level CAN bus
4	Active ABS	27	VSO
6	Wheel speed sensor signal end (FR)	28	EBD warning light
13	Motor Ground	30	Brake switch
14	Low-level CAN bus	31	Wheel speed sensor signal end (RR)
17	Diagnostic K-Line	32	ECU power end (ignition power cable)
18	Wheel speed sensor power end/ground (FR)	33	Wheel speed sensor power end/ground (RL)
19	Wheel speed sensor power end/ground (RR)	34	Wheel speed sensor power end/ground (FL)
20	Wheel speed sensor signal end (RL)	38	ECU Ground
22	Wheel speed sensor signal end (FL)		

ABS SYSTEM WORKING PRINCIPLE DIAGRAM

ABS works by monitoring the speed signal of each wheel through the wheel speed sensor (ABS sensor), which quickly determines the state of wheel lock-up. When it detects that a wheel is about to lock up, ABS quickly adjusts the braking pressure to prevent the wheel from locking up completely. In this way, ABS is able to maintain the optimum wheel slip rate (approx. 20%) during emergency braking, thereby maximising braking effect and reducing brake consumption, extending the service life of brake components.

In addition, ABS has the advantage of improving braking efficiency, enhancing vehicle stability and strengthening driving safety. By intelligently regulating the braking pressure on the wheels, ABS makes more efficient use of braking force, optimises energy recovery and reduces the risk of loss of control due to tyre lock-up.

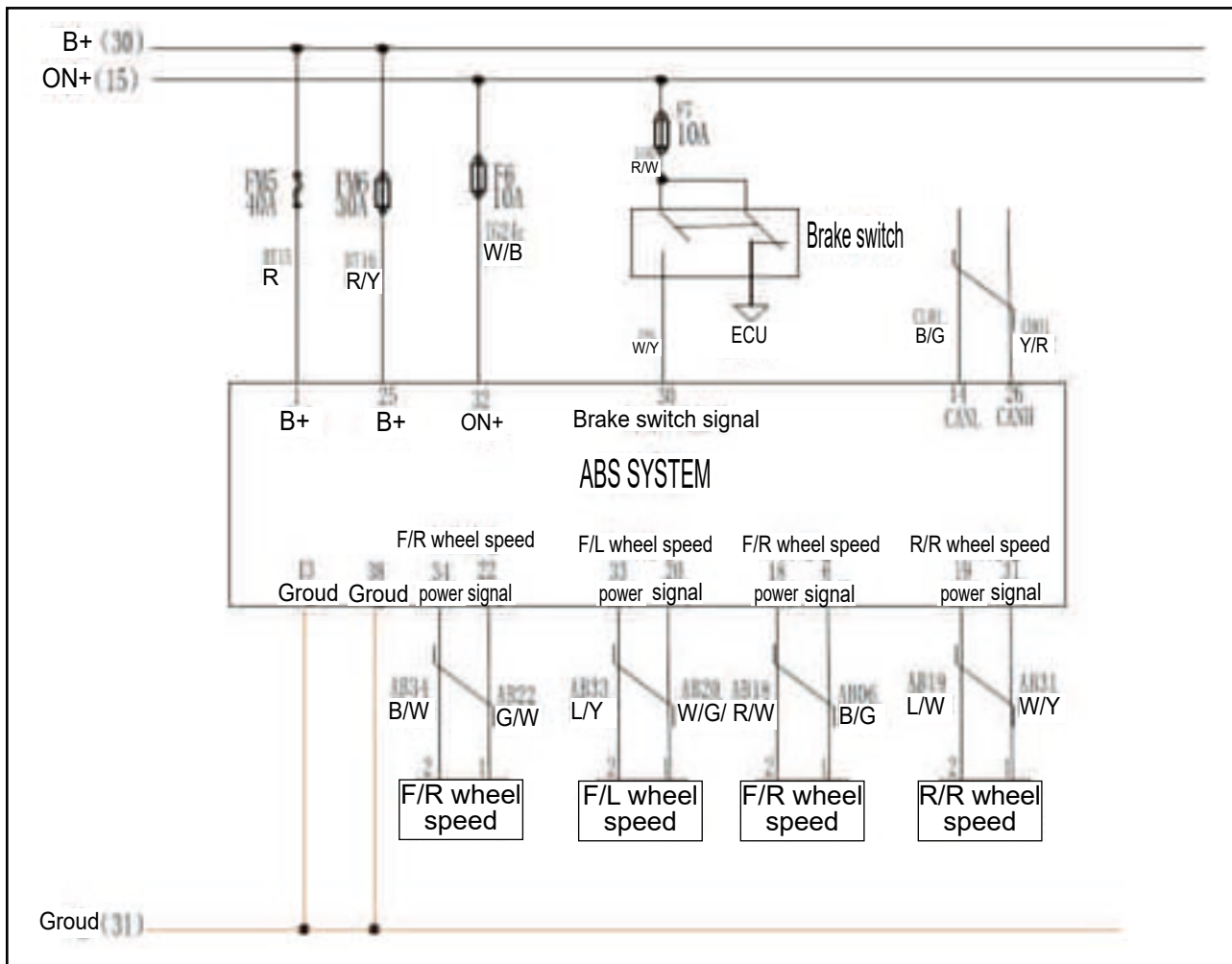

ABS FAULT DIAGNOSIS CODE

Fault code	Explanation (UAES)
A0001	ECU Voltage:too high
A0002	ECU Voltage:too low
A0003	"Wheel-speed sensor, front left: Signal Line short to GND/Open; Supply Line open"
A0004	Wheel-speed sensor, front left: (signal failure) out of range, jitter, Intermittent
A0005	Wheel-speed sensor, front left:No signal
A0006	"Wheel-speed sensor, front right: Signal Line short to GND/Open; Supply Line open"
A0007	Wheel-speed sensor, front right: (signal failure) out of range, jitter, Intermittent
A0008	Wheel-speed sensor, front right: No signal from wheel speed sensor
A0009	"Wheel-speed sensor, rear left: Signal Line short to GND/Open; Supply Line open"
A0010	Wheel-speed sensor, rear left: (signal failure) out of range, jitter, Intermittent
A0011	Wheel-speed sensor, rear left: No signal from wheel speed sensor
A0012	"Wheel-speed sensor, rear right: Signal Line short to GND/Open; Supply Line open"
A0013	Wheel-speed sensor, rear right: (signal failure) out of range, jitter, Intermittent
A0014	Wheel-speed sensor, rear right: No signal from wheel speed sensor
A0015	Wheel-speed sensor generic error (General error of wheel speed sensor (frequency error, gear number error, tire error)
A0016	Valve relay error
A0017	valve fault, inlet valve FL
A0018	valve fault, outlet valve FL
A0019	valve fault, inlet valve FR
A0020	valve fault, outlet valve FR
A0021	valve fault, inlet valve RL
A0022	valve fault, outlet valve RL
A0023	valve fault, inlet valve RR
A0024	valve fault, outlet valve RR
A0025	valve fault(overheating,overcurrent,short circuit,signal error,hadware error)
A0026	Motor error
A0027	Motor relay error
A0028	ECU error (hardware error)
A0029	CAN hardware error
A0030	CAN Bus Off error
A0031	ABS control anomalies failure
A0032	CAN Bus Off error